

## Miniature SPI Digital Barometer

The MPL115A1 is an absolute pressure sensor with digital output for low cost applications. A miniature 5 x 3 x 1.2 mm LGA package ideally suits it for portable electronics and space constrained applications. Low current consumptions of 5  $\mu$ A during Active mode and 1  $\mu$ A during Shutdown (Sleep) mode target battery and other low-power applications. A wide operating temperature range from -40°C to +105°C fits demanding environmental requirements.

MPL115A1 employs a MEMS pressure sensor with a conditioning IC to provide accurate pressure measurement from 50 to 115 kPa. An integrated ADC provides digitized temperature and pressure sensor outputs via a SPI port. Calibration Data is stored in internal ROM. Utilizing raw sensor output, the host microcontroller executes a compensation algorithm to render *Compensated Absolute Pressure* with 1 kPa accuracy.

The MPL115A1 pressure sensor's small form factor, low power capability, precision, and digital output optimize it for barometric measurement applications.

### Features

- Digitized pressure and temperature information together with programmed calibration coefficients for host micro use.
- Factory Calibrated
- 50 kPa to 115 kPa Absolute Pressure
- 1 kPa Accuracy
- 2.375 V to 5.5 V Supply
- Integrated ADC
- SPI Interface
- Monotonic Pressure and Temperature Data Outputs
- Surface Mount RoHS Compliant Package

## MPL115A1

50 to 115 kPa

### Application Examples

- Barometry (portable and desk-top)
- Altimeters
- Weather Stations
- Hard Disk-Drives (HDD)
- Industrial Equipment
- Health Monitoring
- Air Control Systems

### ORDERING INFORMATION

Device Name	Package Options	Case No.	# of Ports			Pressure Type			Digital Interface
			None	Single	Dual	Gauge	Differential	Absolute	
MPL115A1	Tray	2015	•					•	SPI
MPL115A1T1	Tape & Reel (1000)	2015	•					•	SPI
MPL115A1T2	Tape & Reel (5000)	2015	•					•	SPI

### LGA PACKAGE



MPL115A1  
5.0 mm X 3.0 mm X 1.2 mm MAX

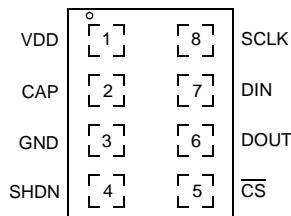

PIN CONNECTIONS

### Pin Description

PIN	NAME	FUNCTION
1	VDD	VDD Power Supply Connection.
2	CAP	External Capacitor
3	GND	Ground
4	SHDN	Shutdown (Sleep): Connect to GND to disable the device. When in shut down the part draws < 1 $\mu$ A supply current
5	CS	CS: SPI Chip Select line.
6	DOUT	DOUT: Serial data output.
7	DIN	DIN: Serial data input.
8	SCLK	SPI Serial Clock Input.

## Maximum Ratings

Voltage (with respect to GND unless otherwise noted)

$V_{DD}$ .....	-0.3 V to +5.5 V
SCLK, $\overline{CS}$ , $D_{IN}$ , $D_{OUT}$ .....	-0.3 V to $V_{DD}+0.3$ V
Operating Temperature Range .....	-40°C to +105°C
Storage Temperature Range.....	-40°C to +125°C
Overpressure .....	1000 kPa

## Operating Characteristics

( $V_{DD}$  = 2.375 V to 5.5 V,  $T_A$  = -40°C to +105°C, unless otherwise noted. Typical values are at  $V_{DD}$  = 3.3 V,  $T_A$  = +25°C.)

Ref	Parameters	Symbol	Conditions	Min	Typ	Max	Units
1	Operating Supply Voltage	$V_{DD}$		2.375	3.3	5.5	V
2	Supply Current	$I_{DD}$	Shutdown (SHDN = GND)	—	—	1	$\mu$ A
			Standby	—	3.5	10	$\mu$ A
			Average – at one measurement per second	—	5	—	$\mu$ A
<b>Pressure Sensor</b>							
3	Range			50	—	115	kPa
4	Resolution			—	0.15	—	kPa
5	Accuracy		-20°C to 85°C	—	$\pm 1$	—	kPa
6	Accuracy Change over Temperature			—	$\pm 0.125$	—	kPa/°C
7	Conversion Time (Start Pressure Convert)	$t_{cp}$	Time between start convert command and data available in the Pressure register	—	0.6	0.7	ms
<b>Temperature Sensor</b>							
8	Range			-40	—	105	°C
9	Conversion Time (Start Temperature Convert)	$t_{ct}$	Time between start convert command and data available in the Temperature register	—	0.6	0.7	ms
10	Conversion Time (Start Both Convert)	$t_{cb}$	Time between start convert command and data available in the Pressure and Temperature registers	—	0.8	1	ms
11	Resolution		Temperature ADC is 472 counts at 25°C	—	-5.35	—	counts/°C
<b>SPI Inputs: SCLK, <math>\overline{CS}</math>, <math>D_{IN}</math></b>							
12	SCLK Clock Frequency	$f_{SCLK}$	<sup>(1)</sup>	—	—	8	MHz
13	Low Level Input Voltage	VIL		—	—	$0.3V_{DD}$	V
14	High Level Input Voltage	VIH		$0.7V_{DD}$	—	—	V
<b>SPI Outputs: <math>D_{OUT}</math></b>							
15	Low Level Output Voltage	VOL1	At 3 mA sink current	0	—	0.4	V
		VOL2	At 6 mA sink current	0	—	0.6	
16	High Level Output Voltage	VOH1	At 3 mA source current	$V_{DD} - 0.4$ V	—	—	V

1. Nominal maximum SPI clock frequency.

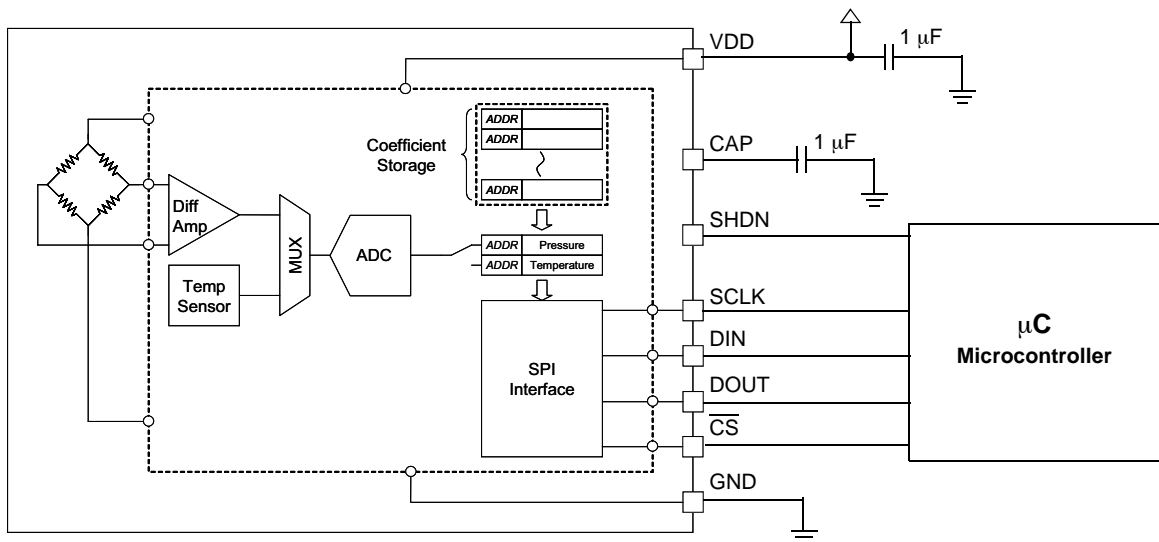

Figure 1. Uncompensated Pressure Sensor Schematic

## Compensation

The pressure compensation for MPL115A1 is based on a 2-dimensional, second order polynomial based on Microsystems mst\_trimlib library.

The 10-bit compensated pressure output,  $P_{comp}$ , is calculated as follows:

$$P_{comp} = a_0 + (b_1 + c_{11} * P_{adc} + c_{12} * T_{adc}) * P_{adc} + (b_2 + c_{22} * T_{adc}) * T_{adc}$$

Where:

- $P_{adc}$  is the 10-bit pressure output of the MPL115A1 ADC,
- $T_{adc}$  is the 10-bit temperature output of the MPL115A1 ADC,
- $a_0$  is the pressure offset coefficient,
- $b_1$  is the pressure sensitivity coefficient,
- $c_{11}$  is the pressure linearity (2nd order) coefficient,
- $c_{12}$  is the coefficient for temperature sensitivity coefficient (TCS),
- $b_2$  is the 1st order temperature offset coefficient (TCO),
- $c_{22}$  is the 2nd order temperature offset coefficient.

Ideally,  $P_{comp}$  will produce a value of 0 with an input pressure of 50 kPa and will produce a full-scale value of 1023 with an input pressure of 115 kPa.

## Coefficient Bit-Width Specs

The table below specifies the initial coefficient bit-width specs for the compensation algorithm.

10-bit Output: Compensation Coefficient Specs							Total Coeff. Bits
	a0	b1	b2	c12	c11	c22	
<b>Total Bits</b>	16	16	16	14	11	11	84
<b>Sign Bits</b>	1	1	1	1	1	1	
<b>Integer Bits</b>	12	2	1	0	0	0	
<b>Fractional Bits</b>	3	13	14	13	11	10	
<b>dec pt zero pad</b>	—	—	—	9	11	15	

Example Binary Format Definitions:

1. Sign = 0, Integer Bits = 8, Fractional Bits = 4 :                      Coeff = S I<sub>7</sub> I<sub>6</sub> I<sub>5</sub> I<sub>4</sub> I<sub>3</sub> I<sub>2</sub> I<sub>1</sub> I<sub>0</sub> . F<sub>3</sub> F<sub>2</sub> F<sub>1</sub> F<sub>0</sub>
2. Sign = 1, Integer Bits = 4, Fractional Bits = 7 :                      Coeff = S I<sub>3</sub> I<sub>2</sub> I<sub>1</sub> I<sub>0</sub> . F<sub>6</sub> F<sub>5</sub> F<sub>4</sub> F<sub>3</sub> F<sub>2</sub> F<sub>1</sub> F<sub>0</sub>
3. Sign = 0, Integer Bits = 0, Fractional Bits = 6, dec pt zero pad = 2 :      Coeff = S 0 . 0 0 F<sub>5</sub> F<sub>4</sub> F<sub>3</sub> F<sub>2</sub> F<sub>1</sub> F<sub>0</sub>
4. Sign = 0, Integer Bits = 0, Fractional Bits = 5, dec pt zero pad = 3 :      Coeff = S 0 . 0 0 0 F<sub>4</sub> F<sub>3</sub> F<sub>2</sub> F<sub>1</sub> F<sub>0</sub>

**NOTE:** Negative coefficients (Sign = 1) are coded in 2's complement notation.

## Coefficient Address Map

Address	Coefficient
\$04	a0 MS Byte
\$05	a0 LS Byte
\$06	b1 MS Byte
\$07	b1 LS Byte
\$08	b2 MS Byte
\$09	b2 LS Byte
\$0A	c12 MS Byte
\$0B	c12 LS Byte
\$0C	c11 MS Byte
\$0D	c11 LS Byte
\$0E	c22 MS Byte
\$0F	c22 LS Byte

For coefficients with less than 16 bits, the lower LSBs are zero. For example, c11 is 11 bits and is stored into 2 bytes as follows:

$$c11 \text{ MS byte} = c11[10:3] = [c11_{b10}, c11_{b9}, c11_{b8}, c11_{b7}, c11_{b6}, c11_{b5}, c11_{b4}, c11_{b3}]$$

$$c11 \text{ LS byte} = c11[2:0] \& \text{"00000"} = [c11_{b2}, c11_{b1}, c11_{b0}, 0, 0, 0, 0, 0]$$

## Solder Recommendations

1. Use SAC solder alloy (i.e., Sn-Ag-Cu) with a melting point of about 217°C. It is recommended to use SAC305 (i.e., Sn-3.0 wt.% Ag-0.5 wt.% Cu).
2. Reflow
  - Ramp up rate: 2 to 3 C/s.
  - Preheat flat (soak): 110 to 130s.
  - Reflow peak temperature: 250°C to 260°C (depends on exact SAC alloy composition).
  - Time above 217°C: 40 to 90s (depends on board type, thermal mass of the board/quantities in the reflow).
  - Ramp down: 5 to 6 C/s.
  - Using an inert reflow environment (with O<sub>2</sub> level about 5 to 15 ppm).

**NOTE:** The stress level and signal offset of the device also depends on the board type, board core material, board thickness and metal finishing of the board.

## Handling Recommendations

It is recommended to handle the MPL115A pressure sensor with a vacuum pick and place tool. Sharp objects utilized to move the MPL115A pressure sensor increase the possibility of damage via a foreign object/tool into the small exposed port.

The sensor die is sensitive to light exposure. Direct light exposure through the port hole can lead to varied accuracy of pressure measurement. Avoid such exposure to the port during normal operation.

PACKAGE DIMENSIONS

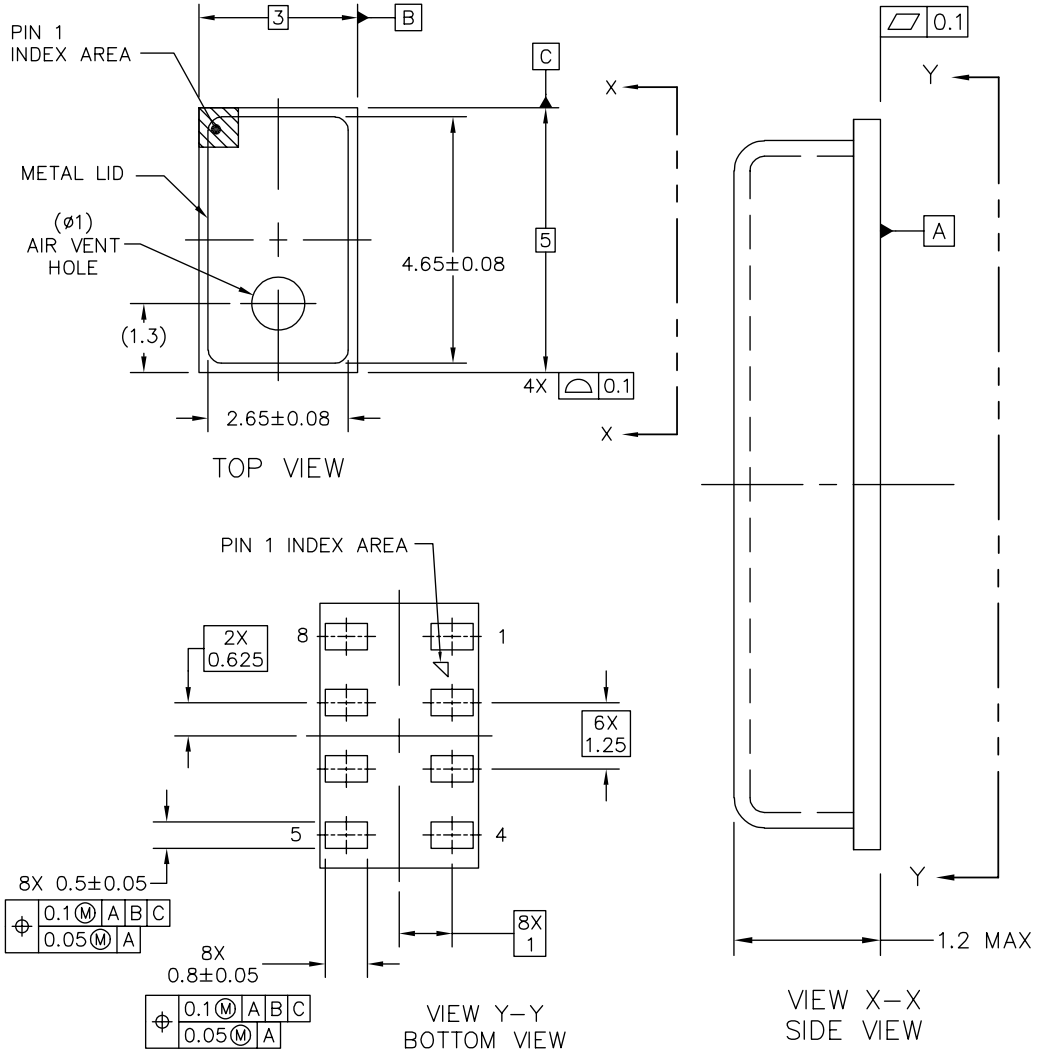

© FREESCALE SEMICONDUCTOR, INC. ALL RIGHTS RESERVED.	<b>MECHANICAL OUTLINE</b>	PRINT VERSION NOT TO SCALE
TITLE: LGA 8 I/O, 3 X 5 X 1.25 PITCH, SENSOR 1.2MAX MM PKG	DOCUMENT NO: 98ASA10829D	REV: A
	CASE NUMBER: 2015-02	10 MAR 2010
	STANDARD: NON-JEDEC	

**CASE 2015-02  
ISSUE A  
LGA PACKAGE**

## PACKAGE DIMENSIONS

## NOTES:

1. ALL DIMENSIONS IN MILLIMETERS.
2. DIMENSIONING AND TOLERANCING PER ASME Y14.5M-1994
3. STYLE:
 

PIN 1: VDD	PIN 5: CS
PIN 2: CAP	PIN 6: DOUT
PIN 3: GND	PIN 7: DIN
PIN 4: SHDN	PIN 8: SCLK

© FREESCALE SEMICONDUCTOR, INC. ALL RIGHTS RESERVED.	<b>MECHANICAL OUTLINE</b>	PRINT VERSION NOT TO SCALE	
TITLE: LGA 8 I/O, 3 X 5 X 1.25 PITCH SENSOR 2.0MM PKG	DOCUMENT NO: 98ASA10829D	REV: A	
	CASE NUMBER: 2015-02	14 APR 2009	
	STANDARD: NON-JEDEC		

**CASE 2015-02  
ISSUE A  
LGA PACKAGE**

MPL115A1

## **How to Reach Us:**

### **Home Page:**

[www.freescale.com](http://www.freescale.com)

### **Web Support:**

<http://www.freescale.com/support>

### **USA/Europe or Locations Not Listed:**

Freescale Semiconductor, Inc.  
Technical Information Center, EL516  
2100 East Elliot Road  
Tempe, Arizona 85284  
1-800-521-6274 or +1-480-768-2130  
[www.freescale.com/support](http://www.freescale.com/support)

### **Europe, Middle East, and Africa:**

Freescale Halbleiter Deutschland GmbH  
Technical Information Center  
Schatzbogen 7  
81829 Muenchen, Germany  
+44 1296 380 456 (English)  
+46 8 52200080 (English)  
+49 89 92103 559 (German)  
+33 1 69 35 48 48 (French)  
[www.freescale.com/support](http://www.freescale.com/support)

### **Japan:**

Freescale Semiconductor Japan Ltd.  
Headquarters  
ARCO Tower 15F  
1-8-1, Shimo-Meguro, Meguro-ku,  
Tokyo 153-0064  
Japan  
0120 191014 or +81 3 5437 9125  
[support.japan@freescale.com](mailto:support.japan@freescale.com)

### **Asia/Pacific:**

Freescale Semiconductor China Ltd.  
Exchange Building 23F  
No. 118 Jianguo Road  
Chaoyang District  
Beijing 100022  
China  
+86 010 5879 8000  
[support.asia@freescale.com](mailto:support.asia@freescale.com)

### **For Literature Requests Only:**

Freescale Semiconductor Literature Distribution Center  
1-800-441-2447 or +1-303-675-2140  
Fax: +1-303-675-2150  
[LDCForFreescaleSemiconductor@hibbertgroup.com](mailto:LDCForFreescaleSemiconductor@hibbertgroup.com)

Information in this document is provided solely to enable system and software implementers to use Freescale Semiconductor products. There are no express or implied copyright licenses granted hereunder to design or fabricate any integrated circuits or integrated circuits based on the information in this document.

Freescale Semiconductor reserves the right to make changes without further notice to any products herein. Freescale Semiconductor makes no warranty, representation or guarantee regarding the suitability of its products for any particular purpose, nor does Freescale Semiconductor assume any liability arising out of the application or use of any product or circuit, and specifically disclaims any and all liability, including without limitation consequential or incidental damages. "Typical" parameters that may be provided in Freescale Semiconductor data sheets and/or specifications can and do vary in different applications and actual performance may vary over time. All operating parameters, including "Typicals", must be validated for each customer application by customer's technical experts. Freescale Semiconductor does not convey any license under its patent rights nor the rights of others. Freescale Semiconductor products are not designed, intended, or authorized for use as components in systems intended for surgical implant into the body, or other applications intended to support or sustain life, or for any other application in which the failure of the Freescale Semiconductor product could create a situation where personal injury or death may occur. Should Buyer purchase or use Freescale Semiconductor products for any such unintended or unauthorized application, Buyer shall indemnify and hold Freescale Semiconductor and its officers, employees, subsidiaries, affiliates, and distributors harmless against all claims, costs, damages, and expenses, and reasonable attorney fees arising out of, directly or indirectly, any claim of personal injury or death associated with such unintended or unauthorized use, even if such claim alleges that Freescale Semiconductor was negligent regarding the design or manufacture of the part.

Freescale and the Freescale logo are trademarks of Freescale Semiconductor, Inc., Reg. U.S. Pat. & Tm. Off.

All other product or service names are the property of their respective owners.

© Freescale Semiconductor, Inc. 2010. All rights reserved.