

# 1.24V Precision Adjustable Shunt Regulator

## FEATURES

- Low Voltage Operation, 1.24V
- Trimmed Bandgap to 0.5% and 1%
- Wide Operating Current, 1mA to 80mA
- Adjustable Output Voltage,  $V_{REF}$  to 18V
- Extended Temp.Range: 0°C to 105°C
- Low Temperature Coefficient, 50 ppm/°C
- Offered in TO-92, SOIC, SOT-23-3
- Replacement for TLV431, AS432

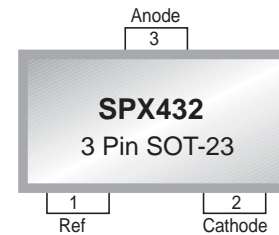

*Now Available in Lead Free Packaging*

Refer to page 11 for other pinouts.

## APPLICATIONS

- Switching Power Supplies
- Adjustable Supplies
- Error Amplifiers
- Single Supply Amplifier
- Monitors / VCRs / TVs
- Personal Computers
- Voltage References

## DESCRIPTION

The SPX432 is a 3-terminal adjustable shunt voltage regulator providing a highly accurate 1.24V bandgap reference with 0.5% tolerance. The SPX432's thermal stability, wide operating current (80mA) and temperature range (0°C to 105°C) makes it suitable for a variety of applications. SPX432 tolerance of 0.5% is proven to be sufficient to overcome all of the other errors in the system to virtually eliminate the need for trimming in the power supply manufacturers' assembly lines and contribute a significant cost savings.

The SPX432 is an ideal voltage reference in an isolated feedback circuit for switch mode power supplies. SPX432 offers many advantages over the TLV431 such as wider output voltage (18V vs. 6V), higher output current (80mA vs. 15mA) and a wider operating temperature range with a tighter tolerance down to 0.5%.

## BLOCK DIAGRAM

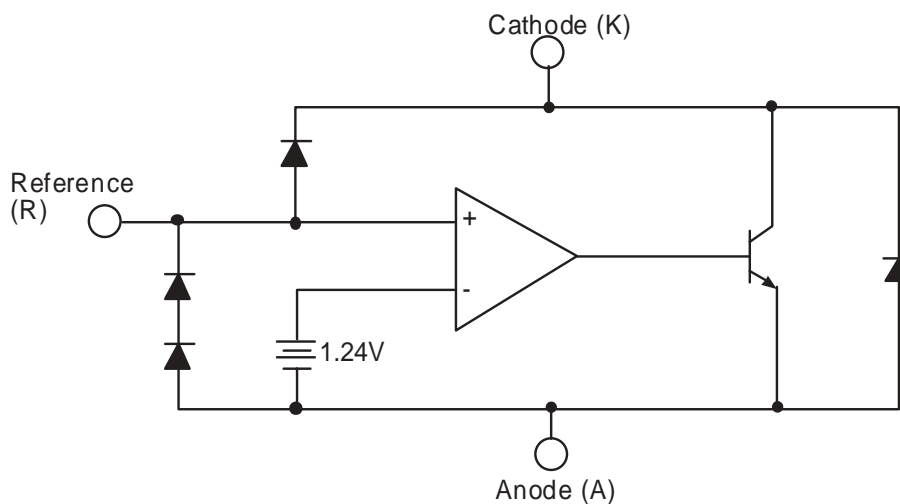

## ABSOLUTE MAXIMUM RATINGS

Cathode-Anode Reverse Breakdown $V_{KA}$ .....	20V
Anode-Cathode Forward Current, (<10ms) $I_{AK}$ .....	1A
Operating Cathode Current $I_{KA}$ .....	80mA
Reference Input Current $I_{REF}$ .....	1mA

Continuous Power Dissipation at 25°C  $P_D$

TO-92 .....	775mW
SOT-23 .....	200 mW
SOIC-8 .....	750mW
Junction Temperature $T_J$ .....	150 °C
Storage Temperature $T_{STG}$ .....	-65°C to 150 °C
Lead Temperature (Soldering 10 sec.) $T_L$ .....	300°C

Stresses greater than those listed under ABSOLUTE MAXIMUM RATINGS may cause permanent damage to the device. This is a stress rating only and functional operation of the device at these or any other conditions above those indicated in the operational sections of this specification is not implied. Exposure to absolute maximum rating conditions for extended periods may affect reliability.

## RECOMMENDED CONDITIONS

PARAMETER	SYMBOL	RATING	UNIT
Cathode Voltage	$V_{KA}$	$V_{REF}$ to 18	V
Cathode Current	$I_K$	10	mA

## TYPICAL THERMAL RESISTANCES

PACKAGE	$\theta_{JA}$	$\theta_{JC}$	TYPICAL DERATING
TO-92	160°C/W	80°C/W	6.3mW/°C
SOT-23	575°C/W	150°C/W	1.7 mW/°C
SOIC-8	175°C/W	45°C/W	5.7mW/°C

Typical deratings of the thermal resistances are given for ambient temperature >25°C.

## ELECTRICAL CHARACTERISTICS

Electrical characteristics are guaranteed over the full junction temperature range (0°C to 105°C). Ambient temperature must be derated based upon power dissipation and package thermal characteristics. Unless otherwise specified, test conditions are:  $V_{KA} = V_{REF}$  and  $I_K = 10mA$ .

PARAMETER	SYMBOL	TEST CIRCUIT	CONDITIONS	SPX432A			SPX432			UNITS
				MIN	TYP	MAX	MIN	TYP	MAX	
Output Voltage	$V_{REF}$	3a		1.2338	1.240	1.2462	1.2276	1.240	1.2524	V
Temperature Deviation	$V_{REF}$	3a	$0 < T_J < 105^\circ\text{C}$		12	20		12	20	mV
Line Regulation	$V_{REF}$	3b	$V_{KA} = 1.25V$ to 15V		19	37		19	37	mV
Load Regulation	$V_{REF}$	3a	$I_K = 1mA$ to 80mA		12	30		12	30	mV
Reference Input Current	$I_{REF}$	3b			3	6		3	6	$\mu\text{A}$
Reference Input Current Temperature Coefficient	$I_{REF}$	3b	$0 < T_J < 105^\circ\text{C}$ ,		0.3	0.6		0.3	0.6	$\mu\text{A}$
Minimum Cathode Current for Regulation	$I_{K(MIN)}$	3a			0.6	1		0.6	1	mA
Off State Leakage	$I_{K(MIN)}$	3c	$V_{REF} = 0V$ , $V_{KA} = 18V$		0.04	500		0.04	500	nA

## CALCULATION AVERAGE TEMPERATURE COEFFICIENT (TC)

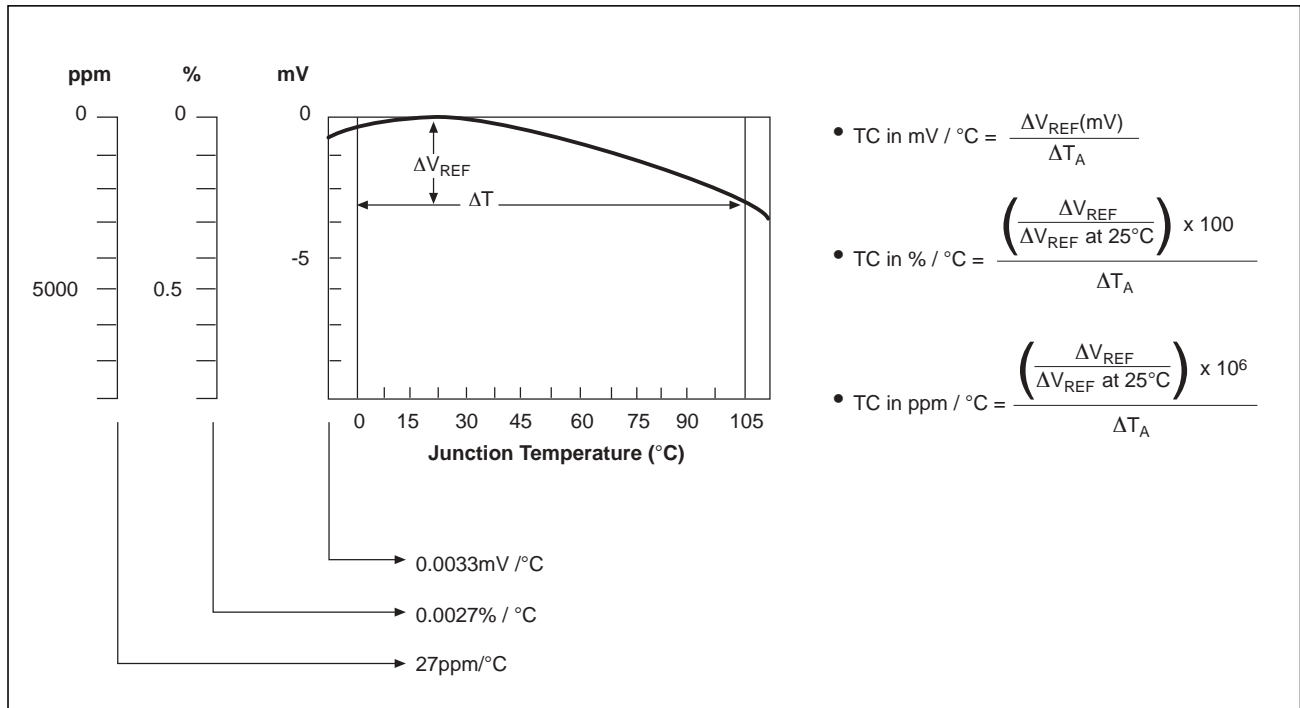

Figure 1.  $V_{REF}$  VS Temperature.

## TEST CIRCUITS

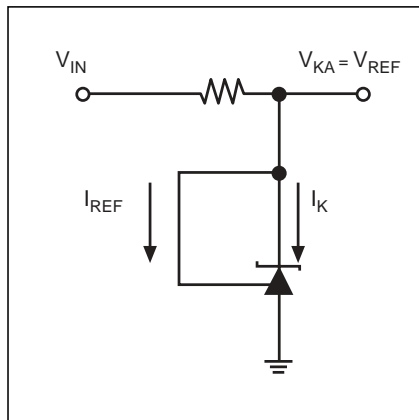

Figure 2. Test Circuit for  $V_{KA} = V_{REF}$

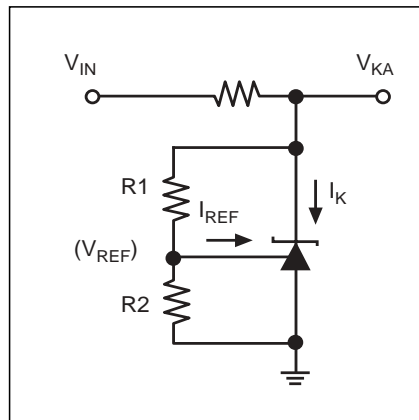

Figure 3. Test Circuit for  $V_{KA} > V_{REF}$

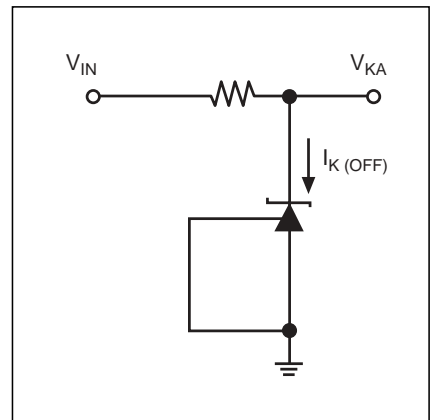
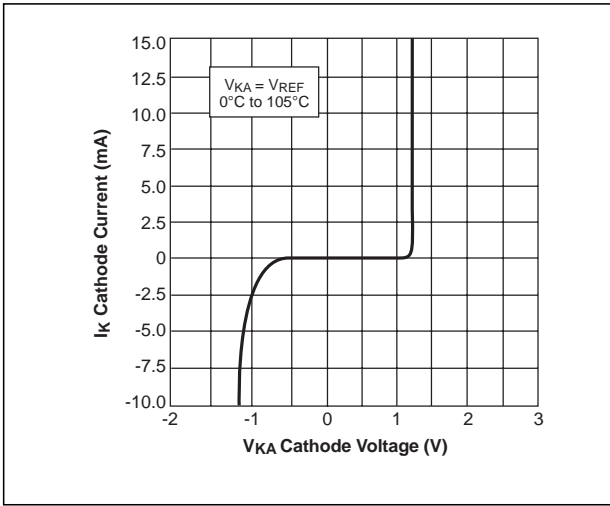
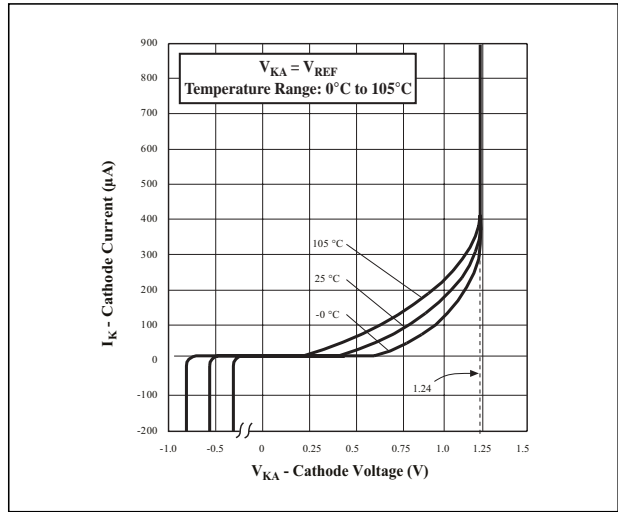

Figure 4. Test Circuit for  $I_{K(OFF)}$

# TYPICAL PERFORMANCE CHARACTERISTICS



High Current Operating Characteristics.



Low Current Operating Characteristics.

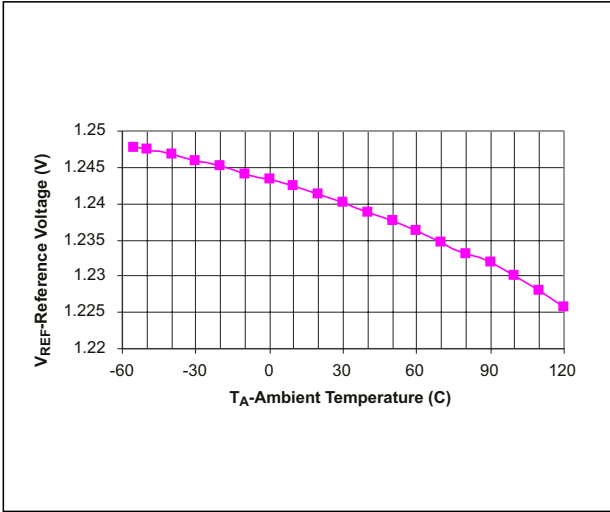

$V_{KA} = V_{REF}, I_{KA} = 10mA.$

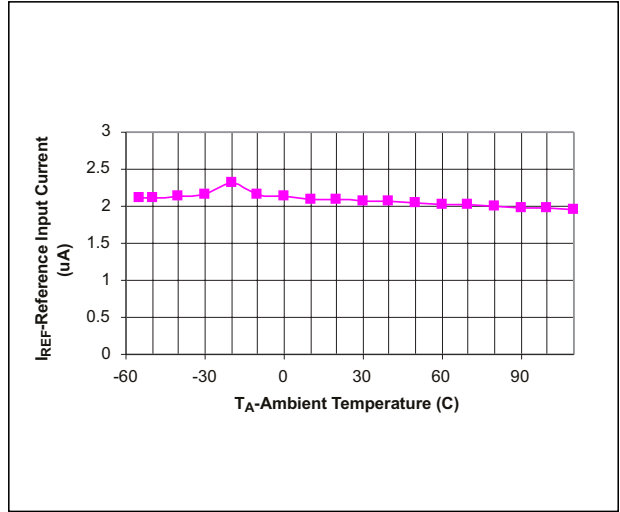

Reference Input Current VS Temperature;  $I_{KA} = 10mA.$

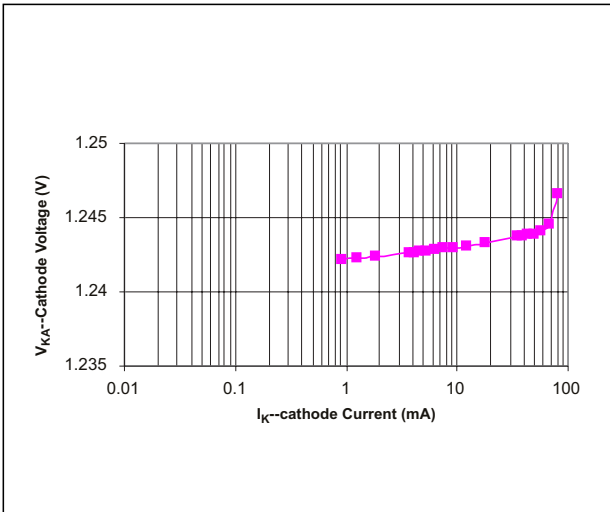

$V_{KA} = V_{REF},$  Sweeping  $I_{KA}, 25^{\circ}C.$

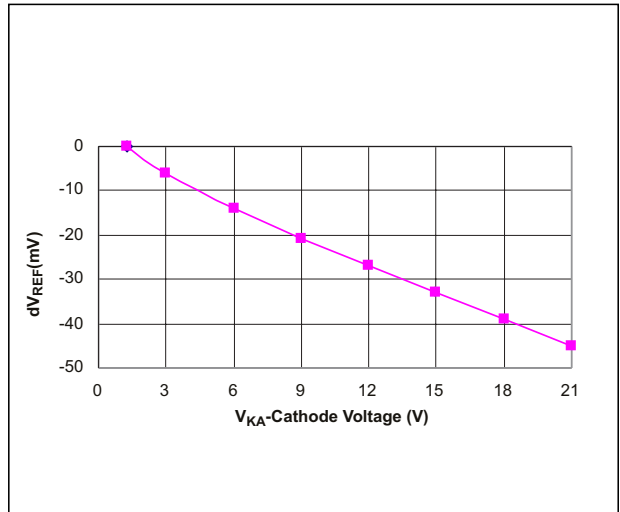

Reference Voltage Line Regulation;  $I_{KA} = 10mA,$  Sweeping  $V_{KA}, 25^{\circ}C.$

# TYPICAL PERFORMANCE CHARACTERISTICS

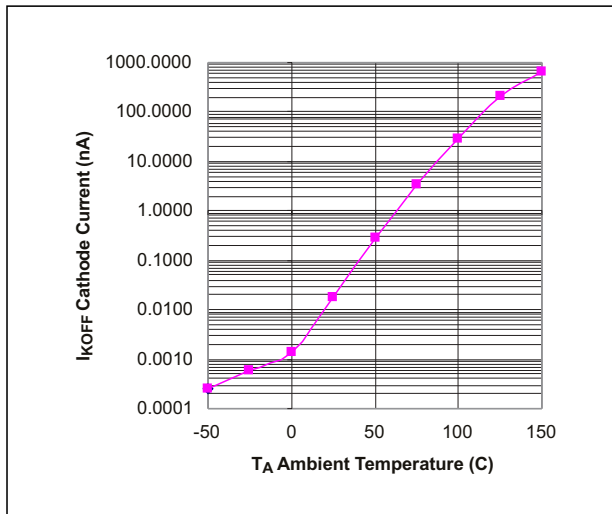

Off State Leakage;  $V_{KA} = 18V$ ,  $V_{REF} = 0V$ .

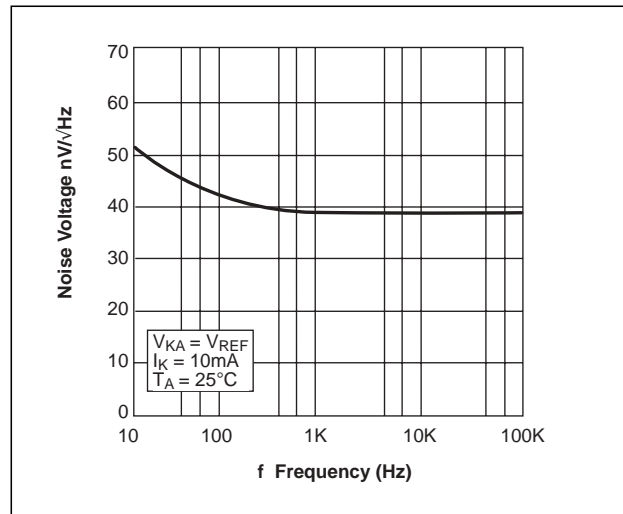

Noise Voltage VS Frequency.

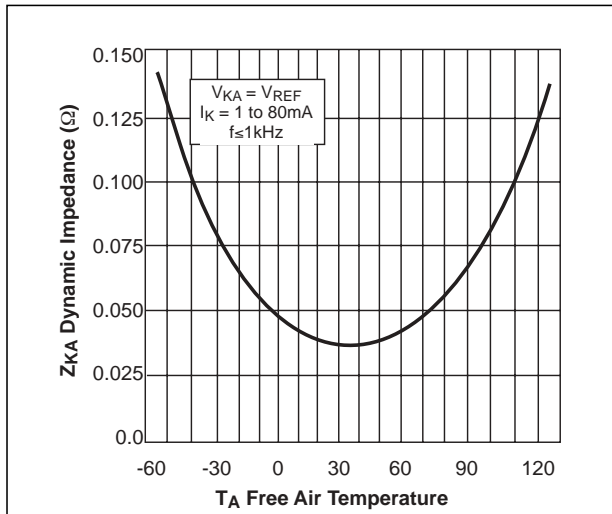

Low Frequency Dynamic Output Impedance VS  $T_{AMBIENT}$

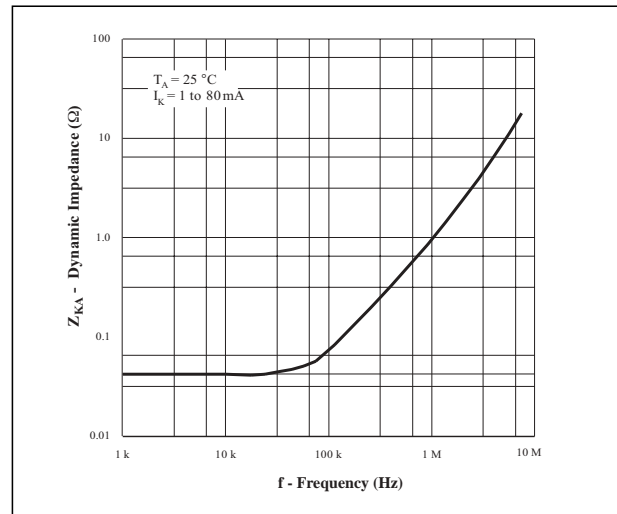

Dynamic Output Impedance  $T_A = 25^\circ C$ ,  $I_{KA} = 1$  to 80mA.

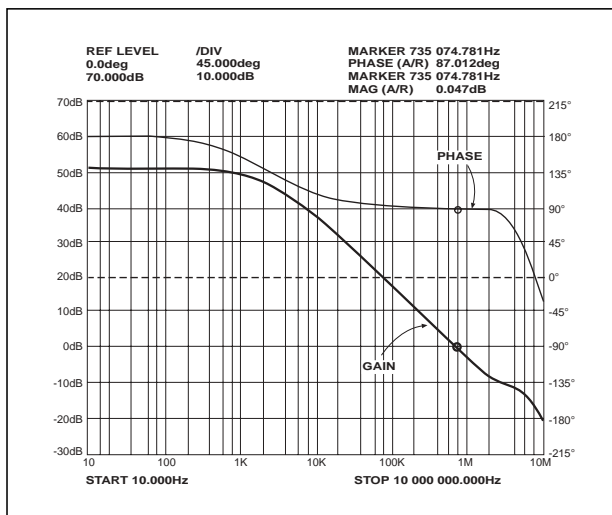

Small Signal Gain and Phase VS Frequency;  $I_K = 10mA$ ,  $T_A = 25^\circ C$ .

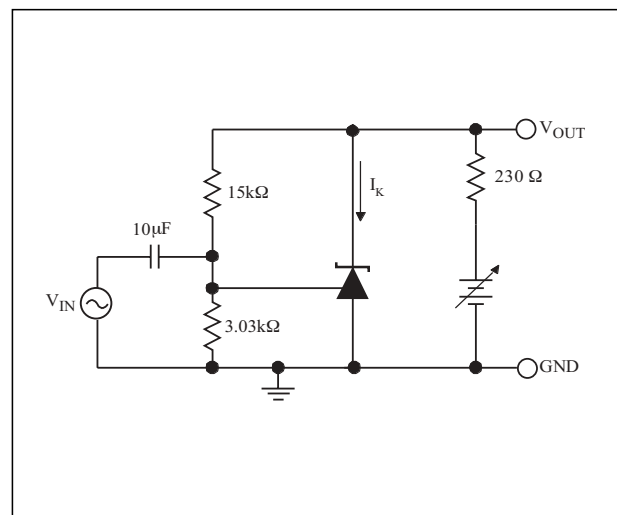

Test Circuit for Gain and Phase Frequency Response.

# TYPICAL PERFORMANCE CHARACTERISTICS

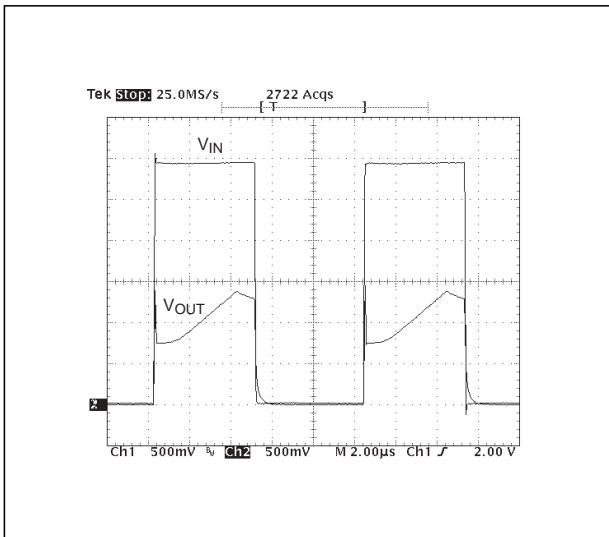

$I_{KA} = 0 \text{ to } 1\text{mA}$ .

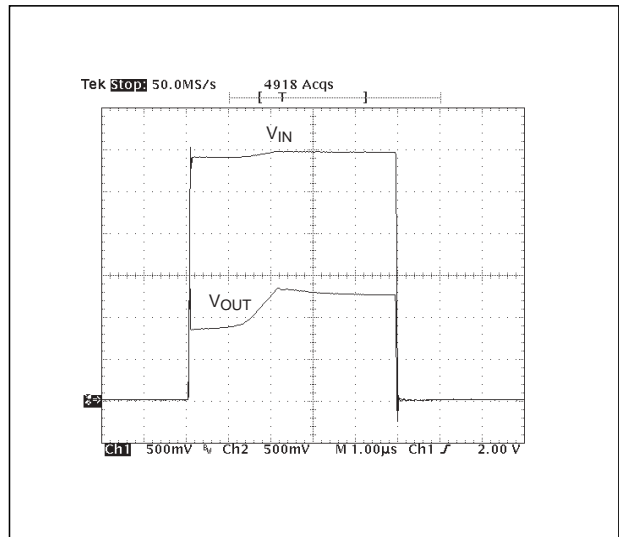

$I_{KA} = 0 \text{ to } 10\text{mA}$ .

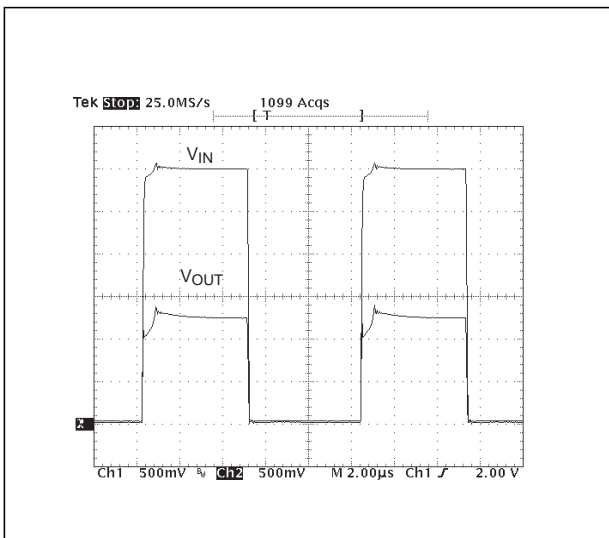

$I_{KA} = 0 \text{ to } 50\text{mA}$ .

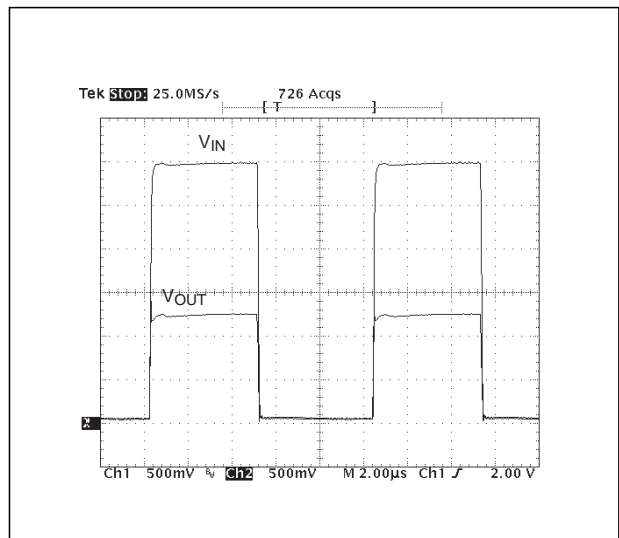

$I_{KA} = 0 \text{ to } 80\text{mA}$ .

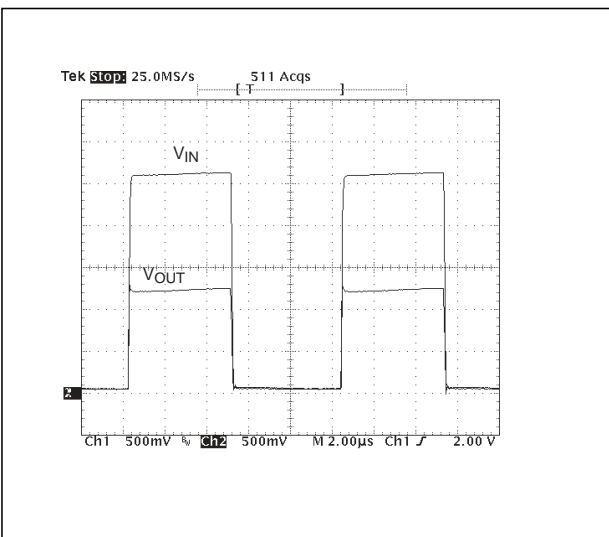

$I_{KA} = 0 \text{ to } 100\text{mA}$ .

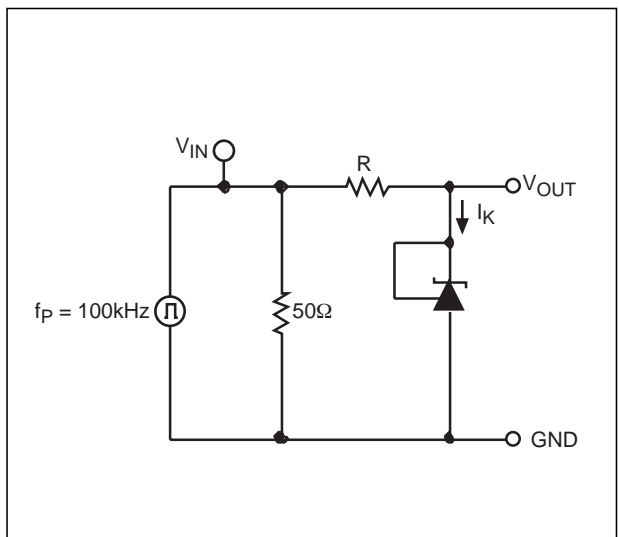

*Test Circuit for Pulse Response.*

## TYPICAL PERFORMANCE CHARACTERISTICS

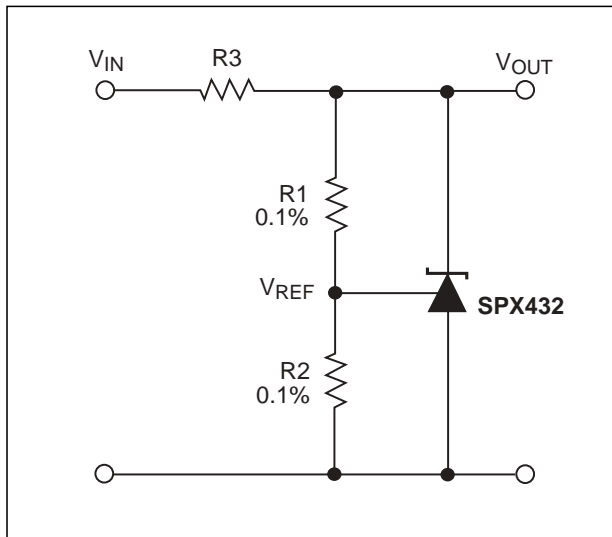

**Shunt Regulator,  $V_{OUT} = (1+R1/R2)V_{REF}$ .**

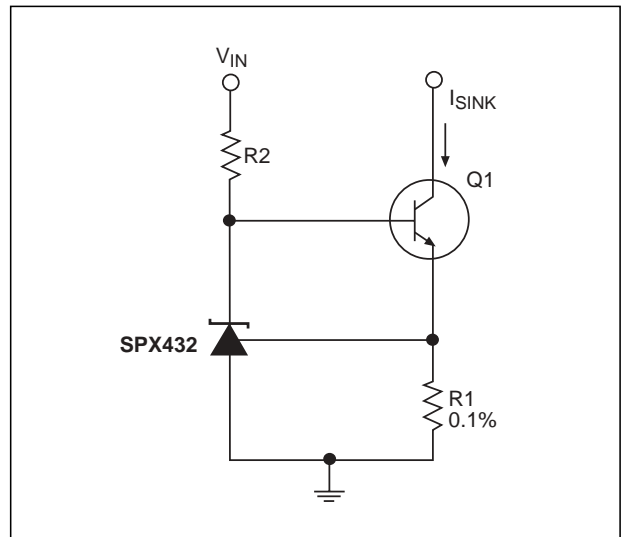

**Constant Current Sink  $I_{SINK} = V_{REF}/R1$ .**

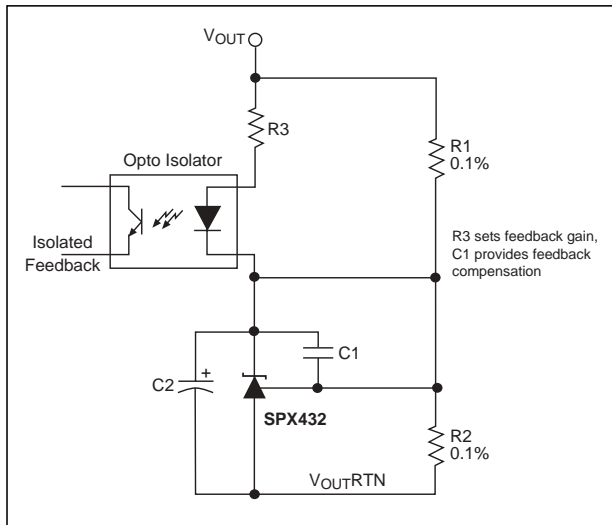

**Reference Amplifier for Isolated Feedback in Off-Line DC-DC Converters.**

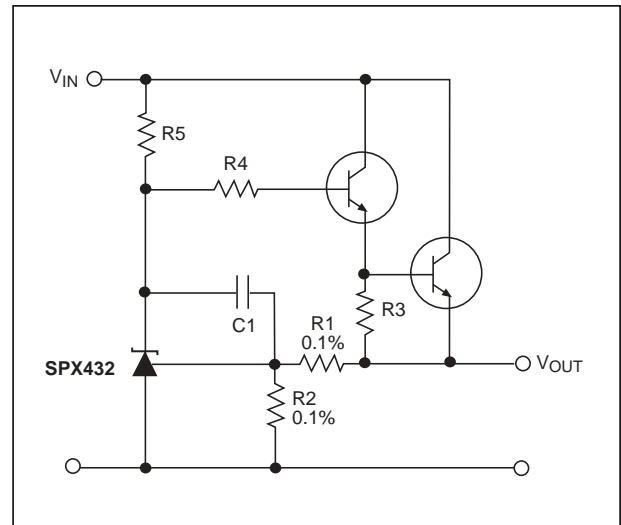

**Precision High Current Series Regulator,  $V_{OUT} = (1+R1/R2)V_{REF}$ .**

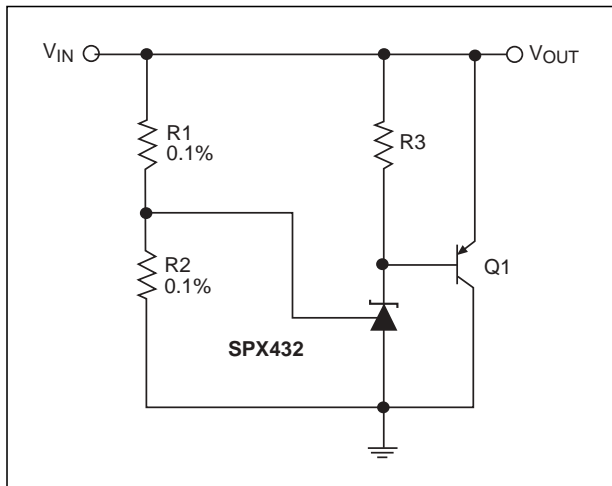

**High Current Shunt Regulator,  $V_{OUT} = (1+R1/R2)V_{REF}$ .**

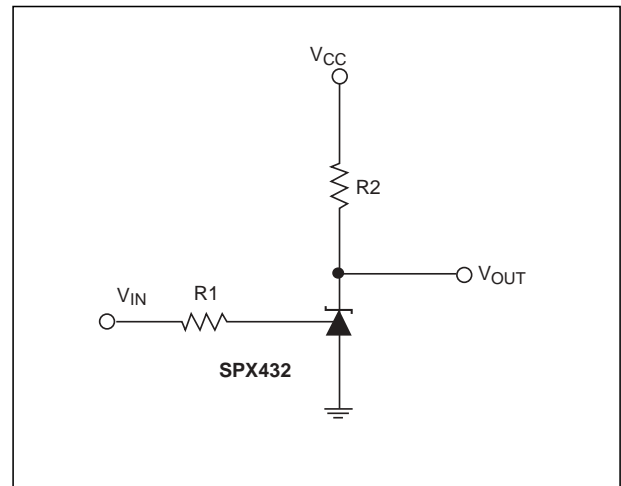

**Single Supply Comparator with Temperature Compensated Threshold,  $V_{IN}$  threshold = 1.24V.**

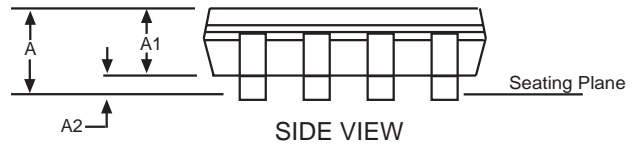
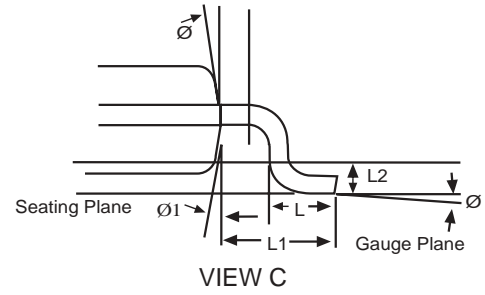
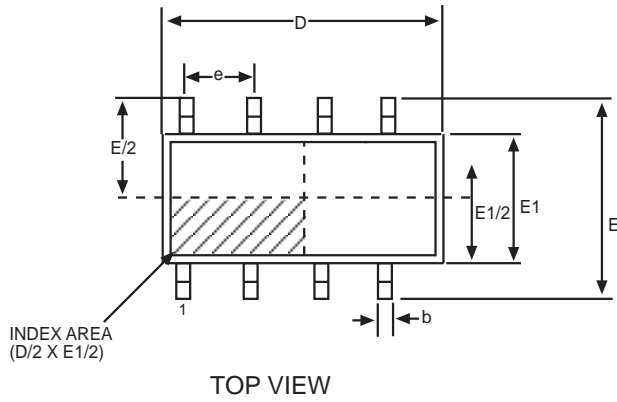

8 Pin NSOIC JEDEC MO-012 (AA) Variation			
SYMBOL	MIN	NOM	MAX
A	1.35	-	1.75
A1	0.1	-	0.25
A2	1.25	-	1.65
b	0.31	-	0.51
c	0.17	-	0.24
D	4.90 BSC		
E	6.00 BSC		
E1	3.90 BSC		
e	1.27 BSC		
L	0.4	-	1.27
L1	1.04 REF		
L2	0.25 BSC		
$\phi$	0°	-	8°
$\phi 1$	5°	-	15°

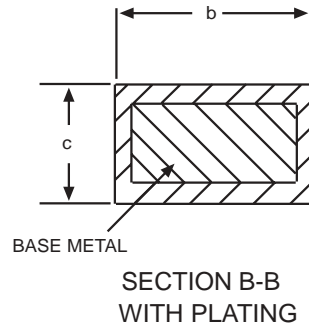
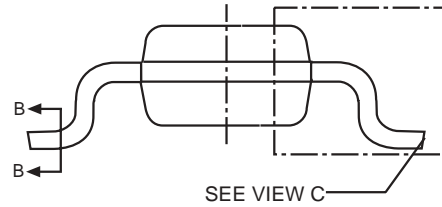

Note: Dimensions in (mm)



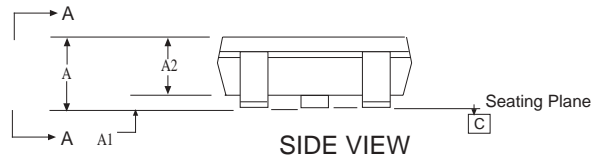
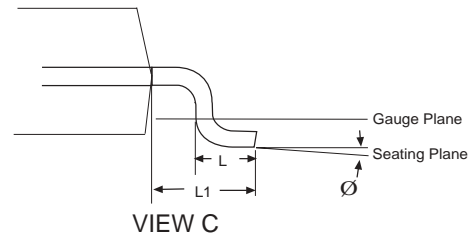
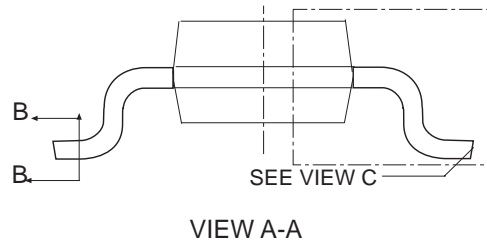
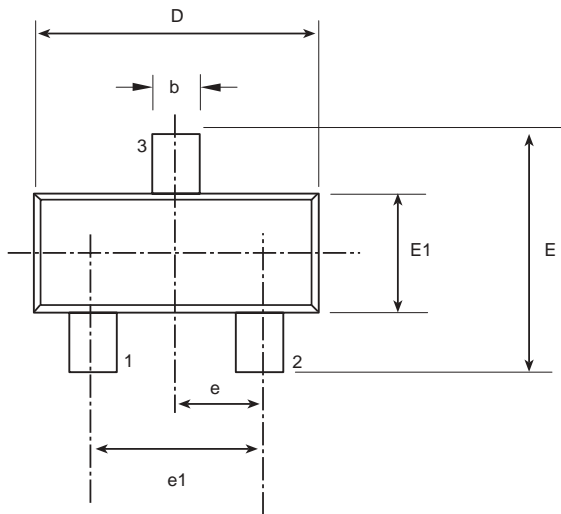

3 Pin SOT-23 JEDEC TO-236 (AB) Variation			
SYMBOL	MIN	NOM	MAX
A	0.89	-	1.12
A1	0.01	-	0.1
A2	0.88	0.95	1.02
b	0.3	-	0.5
c	0.08	-	0.2
D	2.8	2.9	3.04
e	0.95 BSC		
e1	1.90 BSC		
E	0.95	-	2.64
E1	1.2	1.3	1.4
L	0.4	0.5	0.6
L1	0.54 REF		
Ø	0°	-	8°

Note: Dimensions in (mm)

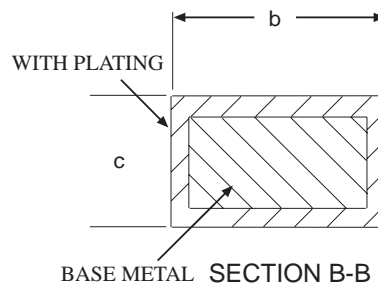

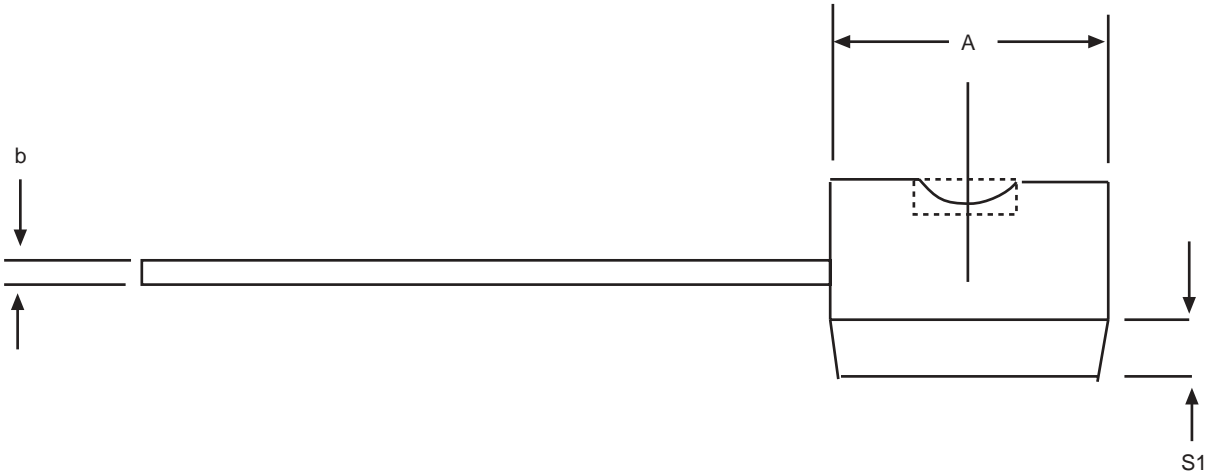
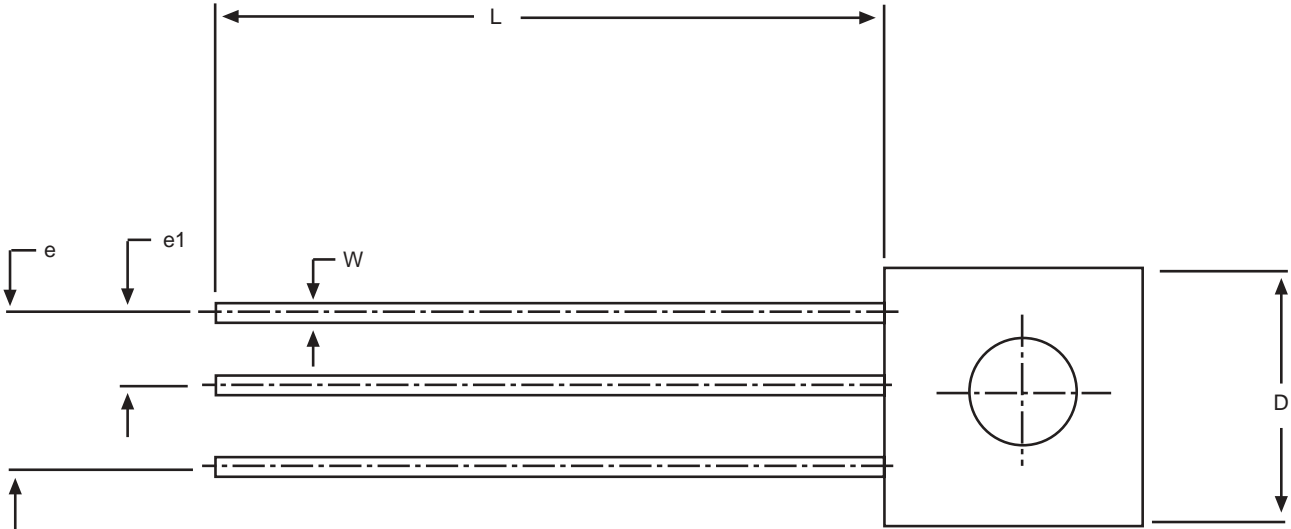

3 Pin TO-92			
SYMBOL	MIN	NOM	MAX
A	0.17	-	0.195
b	0.014	-	0.02
E	0.13	-	0.155
e	0.95	-	0.105
e1	0.045	-	0.055
L	0.5	-	0.61
R	0.085	-	0.095
S1	0.045	-	0.06
W	0.016	-	0.022
D	0.175	-	0.195
a	4°	-	6°

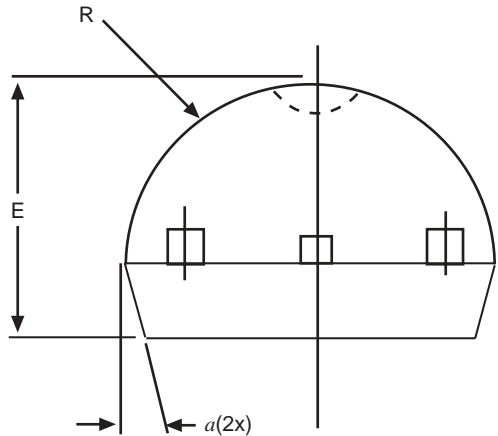

Note: Dimensions in (inches)

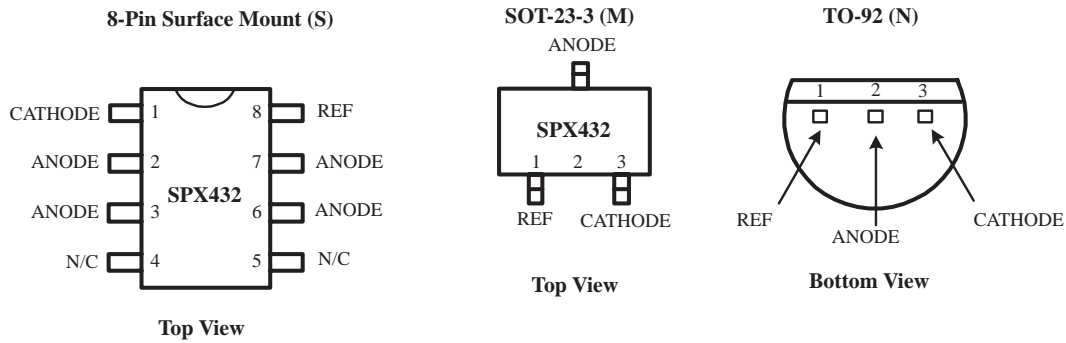

**ORDERING INFORMATION**

PART NUMBER	ACC	OUTPUT VOLTAGE	PACKAGES
SPX432AM .....	0.5% .....	1.24V .....	3-Pin SOT-23
SPX432AM/TR .....	0.5% .....	1.24V .....	3-Pin SOT-23
SPX432AS .....	0.5% .....	1.24V .....	8-Pin NSOIC
SPX432AS/TR .....	0.5% .....	1.24V .....	8-Pin NSOIC
SPX432AN .....	0.5% .....	1.24V .....	3-Pin TO-92
SPX432AN/TR .....	0.5% .....	1.24V .....	3-Pin TO-92
SPX432M .....	1.0% .....	1.24V .....	3-Pin SOT-23
SPX432M/TR .....	1.0% .....	1.24V .....	3-Pin SOT-23
SPX432S .....	1.0% .....	1.24V .....	8-Pin NSOIC
SPX432S/TR .....	1.0% .....	1.24V .....	8-Pin NSOIC
SPX432N .....	1.0% .....	1.24V .....	3-Pin TO-92
SPX432N/TR .....	1.0% .....	1.24V .....	3-Pin TO-92

Available in lead free packaging. To order add "-L" suffix to part number.

Example: SPX432AM/TR = standard; SPX432AM-L/TR = lead free

/TR = Tape and Reel

Pack quantity is 2,000 for TO-92 and 2500 for SOT-23 and NSOIC.

[CLICK HERE TO ORDER SAMPLES](#)



**ANALOG EXCELLENCE**

**Sipex Corporation**

**Headquarters and Sales Office**

233 South Hillview Drive  
 Milpitas, CA 95035  
 TEL: (408) 934-7500  
 FAX: (408) 935-7600

Sipex Corporation reserves the right to make changes to any products described herein. Sipex does not assume any liability arising out of the application or use of any product or circuit described herein; neither does it convey any license under its patent rights nor the rights of others.