

1 FEATURES

- Protects relay contacts from damage during switching due to arcing of mains voltage
- Significantly reduces Electro-Magnetic Interference (EMI) by reduction of switching transients and arcing
- Can be triggered by either a logic signal or sensor input
- Will support an increased relay switching rate
- Provides a complete sensing and control solution
- On chip circuit protection against triac gate spikes
- Low supply current requirement
- Significantly extends relay contact lifetime in constant switching applications - ideal for heating element control
- Uses a small inexpensive triac to momentarily protect the relay from arcing during switching - open and close
- Intelligently triggers contact protecting circuit only when transients are detected, and only during switching
- Sensor AC powered, thus minimising DC supply and filtering needs
- Is able to protect relays connected to both resistive and inductive loads
- Relay control does not suffer from the heat dissipation limitations of similar triac control solutions
- Can be used to drive a load other than a relay, directly from the SCR

2 GENERAL DESCRIPTION

The IES5541A is a monolithic bipolar control circuit for driving a relay so as to protect its contacts from arcing during switching operations. This IC will significantly extend the lifetime of relays which would otherwise suffer from burning, pitting and increased resistance of contacts, eventually leading to complete fusing of the contacts. Additionally, it will significantly reduce EMI / RFI noise caused by arcing of the relay contacts, helping in achieving regulatory requirements.

The IES5541A can be interfaced to a simple logic drive from a microprocessor or other device. It may be interfaced to a serial bus using a simple general purpose I/O interface IC, allowing the circuit (or multiple circuits) to be switched remotely. Alternately, it can be connected directly to a resistive sensor such as an NTC (negative temperature coefficient) thermistor. In this configuration it provides a complete temperature control solution using relay drive. It is ideal for use in situations where the heat dissipation of a triac control solution causes problems. (The contact protection triac in this circuit dissipates an insignificant amount of power.)

3 TYPICAL APPLICATION

In a typical application the IES5541A may be used for the temperature control of a heating element in a cooktop, electric iron, frying pan, or other relay switched mains power control applications.

4 BLOCK DIAGRAM

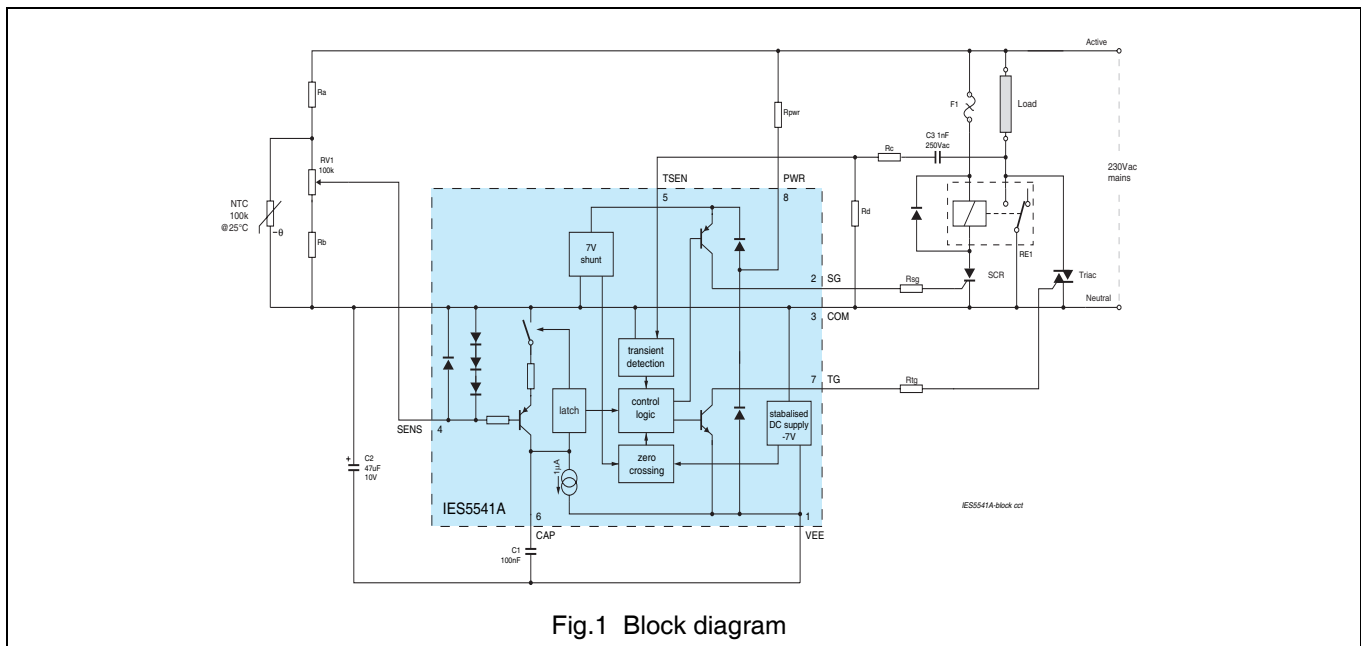
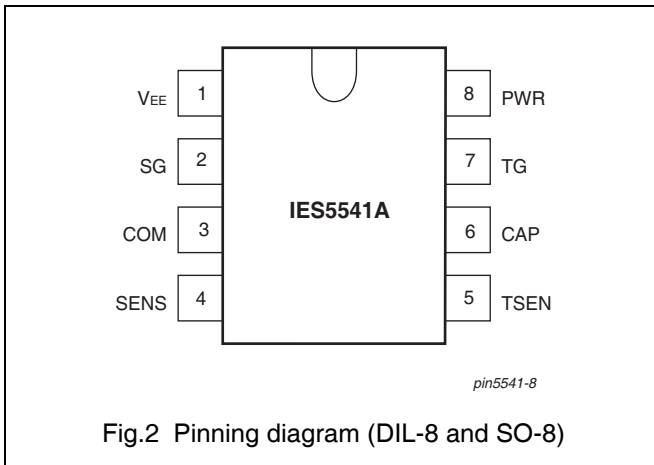

Fig.1 Block diagram

5 PINNING INFORMATION

5.1 Pinning layout (8 pin)



5.2 Pin description (8 pin)

SYMBOL	PIN	DESCRIPTION
V _{EE}	1	Negative supply
SG	2	SCR gate drive
COM	3	Common, Positive supply
SENS	4	Temperature sense input
TSEN	5	Relay Transient/Arc Sense
CAP	6	Timing capacitor / Logic Input
TG	7	Triac gate drive
PWR	8	Power supply input

6 FUNCTIONAL DESCRIPTION

6.1 COM – Common DC supply

This DC supply rail for the control IC IES5541A is used as the Common reference. It is connected to the T1 terminal of the triac and the cathode terminal of the SCR. This enables positive gate drive to the SCR during positive supply half cycles on the anode, and negative gate drive to the triac in both positive and negative supply half cycles on T2. Both a positive (V_{CC}) and negative (V_{EE}) supply rail with respect to COM, are generated inside the IC, however only COM and V_{EE} are accessible outside of the IC.

6.2 V_{EE} – Substrate, negative DC supply

The substrate connection is the negative DC power supply terminal of the IES5541A. This should be bypassed to COM by a filtering capacitor. This capacitor needs to be sufficiently large to maintain the operating voltage during the positive mains half cycle when it is not being charged, as well as to provide the energy to the IC and to drive the triac gate during gate pulses. The operating voltage is typically –7.0 volts.

6.3 PWR – Power supply and synchronisation

For the IES5541A the PWR input is connected to the active mains supply rail via a dropping resistor. For a 220/250 volt mains supply line, the value of this resistor would typically be 270 kΩ. The size of this resistor will however need to be adjusted to suit the number of triac gate pulses that are being produced during the relay switching.

The PWR input signal is rectified to provide the internal supply voltage, and also provides the synchronising information required by the IES5541A to generate the zero crossing signal.

6.4 TSEN – Transient Sense

The relay contact to be protected is connected to the TSEN pin via a series resistor and capacitor. Transient signals on this pin caused by the first signs of arcing across the relay contacts are quickly detected, and the triac is fired to protect the contact.

The triac is not intended to suppress other transients on the mains supply which are not caused by the opening or closing operation of the relay. Consequently the triac may only be fired during a mains derived time “window” after an opening or closing operation. This ensures that a small, inexpensive triac can be chosen for the protection function.

The time “window” is derived by counting 4 complete mains cycles. Assuming a 50Hz mains frequency, the transient detection window will be 80ms.

6.5 SG – SCR gate drive

The SG pin is used to control the gate of the SCR that drives the relay coil. The output from this pin is positive with respect to COM (i.e. it uses the positive internal rail, V_{CC}). It is fired for each full positive half cycle of the mains, after the CAP pin is set “high”. This means, if the CAP pin is set high during a positive half cycle, the IC will wait for the completion of that positive half cycle, and the subsequent negative half cycle, before beginning the first

SCR gate pulse. This could be up to as much as 20ms delay (assuming 50Hz mains frequency) between CAP going high and the first SCR gate pulse.

When the CAP pin is set “low”, the SCR gate drive will not terminate until the next zero crossing of mains. This ensures that the SCR gate is being driven for complete positive mains cycles only. The SCR gate drive output current is limited by an external resistor.

6.6 TG – Triac gate drive

The IC provides negative (with respect to COM) gate pulses to the triac. By driving the triac with negative gate pulses, the insensitive quadrant (negative T2 voltage, and positive gate triggering signal) is avoided. The triac gate drive output current is limited by an external resistor.

The IES5541A detects transients across the relay contacts during the previously defined time “window” and produces a 100µs gate pulse upon detection. The triac then carries the transient current and hence protects the relay contacts.

The IES5541A also provides triac gate pulses at mains zero crossings during a relay closing operation and continues to have the transient detection function as previously mentioned. This essentially makes the relay look like it’s being switched on and off at mains zero crossings reducing the EMI to an absolute minimum. When selecting the triac to be used its current rating must be observed as it will carry the full load current for the time it takes the relay to close.

6.7 CAP – Timing capacitor or logic input

6.7.1 CAP AS A LOGIC INPUT

The IES5541A can be driven in two ways, with a “logic” input, or a sensor input. To drive the IC from a “rail-to-rail” logic signal, such as may be obtained from the output of a microprocessor or other device, this signal is connected to the CAP pin. Additionally, the SENS pin should be connected to COM (figure 4).

In this configuration, a logic high signal ($V_{CAP} > \text{COM}-1.2\text{V}$) causes gate pulses to be sent to the SCR, turning on the relay, while a logic low signal ($V_{CAP} < V_{EE}+0.6\text{V}$) ceases this operation. A rising or falling edge on this pin will begin the 80ms time window for sensing transients on the relay contact.

If the user wishes to use the IES5541A supply rails (COM and V_{EE}) to power an external logic device, the added current consumption must be taken into account when determining the supply resistor connected to the PWR pin.

Additionally, as V_{EE} is typically -7.0 volts (below COM), an appropriate device such as HE series logic must be used. If it is desired to run a 5V logic device from the IES5541A supply rails, the designer must include a dropping resistor and a zener diode clamp, or LDO regulator to its supply, and the outputs must be open-collector to allow pull-up to the logic high level.

Alternately, an external positive supply may be independently generated above the COM rail to supply the logic devices. The resulting drive signal must then be level shifted to the negative polarity signal required by CAP (see figure 5).

6.7.2 CAP AS A TIMING INPUT

In this case a timing capacitor is connected between the CAP pin and the substrate (V_{EE}). The discharge time of this capacitor sets the SCR and hence relay ON time, and is proportional to the capacitance value (approximately 4 seconds per micro farad). The charging period, or OFF time, varies with the magnitude of the input signal from the sensor (figure 3).

The initiation of an ON period is suppressed until the chip power supply reaches its regulated value. After reaching a valid V_{EE} the chip will stay in operation even if the supply falls to about 4 volts. It won’t however, initiate the next ON period until the supply has recovered again.

6.8 SENS – Sensor input

The sensor input is designed to accept an input which is an AC signal referenced to common; thereby avoiding problems associated with the power dissipation involved in generating sufficient DC current to drive the sensor over its full operating resistance range. If a suitable resistive sensor is used with a parallel level setting potentiometer to apply a proportion of the AC sensor signal to the SENS input, a typical circuit will power this via a 270 kΩ resistor from the mains supply. The SENS input signal threshold is one V_{BE} below the COM rail. Signals with a magnitude greater than this V_{BE} charge the timing capacitor towards the COM rail until it reaches the upper threshold which initiates an ON cycle. Signals with a magnitude less than this do not charge the capacitor on the CAP pin, and the relay/SCR drive remains OFF.

External circuits may be used to give greater temperature linearity and accuracy, and improved performance with variation in ambient temperature. The SENS input is only active on negative signals with respect to COM, and therefore either a full AC input may be used, or a signal that is only negatively going with respect to COM.

7 LIMITING VALUES

In accordance with the Absolute Maximum Rating System (IEC 134) Voltages are specified with respect to pin 3 (COM)

SYMBOL	PARAMETER	CONDITIONS	MIN.	MAX.	UNIT
V_{EE}	Supply voltage range (V_{EE})	V_{1-3}	-7.7	+0.5	V
V_{PWR}	Voltage range (PWR)	V_{8-3}	$V_1-0.8$	+8.4	V
V_{CAP}	Voltage range (CAP)	V_{6-3}	$V_1-0.8$	+0.8	V
V_{TSEN}	Voltage range (TSEN)	V_{5-3}	-1.6	+1.6	V
V_{SENS}	Voltage range (SENS)	V_{4-3}	-1.8	+0.8	V
V_{SG}	Voltage range (SG)	V_{2-3}	-0.8	+7.0	V
V_{TG}	Voltage range (TG)	V_{7-3}	$V_1-0.8$	+2.4	V
I	DC current (any pin)		-	±20	mA
P_{tot}	total power dissipation		-	300	mW
T_{stg}	storage temperature		-40	+150	°C
T_{amb}	operating ambient temperature		0	+100	°C

8 CHARACTERISTICS

At $T_{amb} = 25^{\circ}\text{C}$; Voltages are specified with respect to pin 3 (COM)

SYMBOL	PARAMETER	CONDITIONS	MIN	TYP	MAX	UNIT
Power supply						
$-V_{EE}$	supply voltage (operating)		6.4	7.0	7.7	V
$-I_{EE}$	supply current (operating)	excluding gate drive	-	140	210	μA
Gate drive						
I_{SG}	gate current (SCR cathode to COM)	set by R_4 connected from SG to gate	-	-	5	mA
V_{SG}	voltage at SG pin during SCR drive		-	7.0	-	V
I_{TG}	gate current (triac T1 to COM)	set by R_5 connected from TG to gate	-	-	-50	mA
t_{TRG}	gate pulse width	transient triggered	80	100	120	μs
t_{TRG}	gate pulse width	zero crossing triggered	130	150	170	μs
Timing capacitor / Logic input						
$-I_{CAP}$	discharge current		-	1	2.2	μA
$-V_{UT}$	CAP pin upper threshold		-	1100	-	mV
$-V_{LT}$	CAP pin lower threshold		-	$V_{EE}+600$	-	mV
I_{CAP}	charge current	$I_{SENS} = -20 \mu\text{A}$	-	150	-	μA
Transient Sense input						
$-V_{TSENS}$	sense voltage	$I_{TSENS} = -120 \mu\text{A}$	-	950	-	mV

SYMBOL	PARAMETER	CONDITIONS	MIN	TYP	MAX	UNIT
Sense input						
$-V_{\text{SENS}}$	sense voltage	$I_{\text{SENS}} = -20 \mu\text{A}$	–	1000	–	mV
$-V_{\text{SENS}}$	sense voltage	duty cycle = 50%	–	575	–	mV
$-\Delta V_{\text{SENS}}/^\circ\text{C}$	temperature sensitivity		–	2.2	–	mV/ $^\circ\text{C}$
$V_{\text{SENS(rms)}}$	AC sense voltage	Duty cycle = 5%	–	0.47	–	$V_{\text{(rms)}}$
$V_{\text{SENS(rms)}}$	AC sense voltage	Duty cycle = 25%	–	0.48	–	$V_{\text{(rms)}}$
$V_{\text{SENS(rms)}}$	AC sense voltage	Duty cycle = 50%	–	0.50	–	$V_{\text{(rms)}}$
$V_{\text{SENS(rms)}}$	AC sense voltage	Duty cycle = 75%	–	0.53	–	$V_{\text{(rms)}}$
$V_{\text{SENS(rms)}}$	AC sense voltage	Duty cycle = 95%	–	0.65	–	$V_{\text{(rms)}}$
$V_{\text{SENS(rms)}}$	AC sense voltage	Duty cycle = 100%	–	0.73	–	$V_{\text{(rms)}}$

9 APPLICATION INFORMATION

9.1 Design considerations

Figure 3 shows a typical simple circuit for controlling a heating element using an NTC.

Figure 4 shows an example of how a logic signal can be connected to the CAP pin to drive a contact protected relay.

Figure 5 shows two possible configurations for powering a logic device in circuit with the IES5541A.

Figure 6 shows a typical circuit for controlling a contact protected relay from a remote distance using a two wire serial bus such as the I²C Bus⁽¹⁾.

Refer to HM226 for a 48V relay coil application.

9.1.1 POWER SUPPLY REQUIREMENTS

When choosing a suitable supply resistor (R2) the amount of current to be used by the circuit will be application dependant. The most critical supply for the IES5541A is the negative supply, however the positive should be checked to ensure sufficient SCR gate current is available as well.

When calculating the current requirements from R2 for the negative supply it must include the IC's supply current, the triac gate drive current and current required by any added external circuitry.

The maximum continuous current consumption of the IES5541A can be read straight from the characteristics table on page 4 to be 210 μA . The current consumption of the triac gate is however not so predictable as it is

dependant upon the relay characteristics along with the gate current limiting resistor used and the frequency of detected transients. As the transient detection will be a random event and not predictable, it is suggested that a supply capacitor be used that is sufficiently large to carry the supply past the time "window" and a supply resistor be used that is sufficiently large to recover the supply again after the "window". It should be assumed that the gate could give 3 or 4 pulses of 100 μs in length due to transients on the relay contacts. The IES5541A will give 8 gate pulses during mains zero crossings for the relay turn on which should also be considered.

9.1.2 TEMPERATURE SENSING

The application circuit in figure 3 is the simplest configuration in which a negative temperature coefficient (NTC) thermistor or another resistive sensing element can be used. Note that at the low temperature end of the potentiometer travel no sensing signal is available at all. However simple resistor networks are usually needed to linearise the response of the setting resistor against control temperature, and can easily be designed to allow for maximum and minimum operating points. Alternatively these might be set mechanically by stops inherent in the mechanical construction of the product.

Some applications require more accurate control over a limited temperature range; for example the control of fish tank heaters or water bed thermostats. Use of an input bridge circuit (Refer to AN004) with gain will permit greater accuracy, and exhibit less ambient temperature dependence (for example by using one external transistor). These circuits still use an AC sensing circuit, and therefore do not provide any additional loading on the DC power supply.

(1) I²C is a trademark of Philips Electronics N.V.

9.1.3 INDUCTIVE LOADS

It should be noted that for inductive loads the current will be lagging the voltage. Therefore every time the triac turns off it will produce a transient and hence be retriggered by the transient detection circuit of the IES5541A. This means that the load will only be turned off after the 80ms window has expired.

9.2 Application circuits

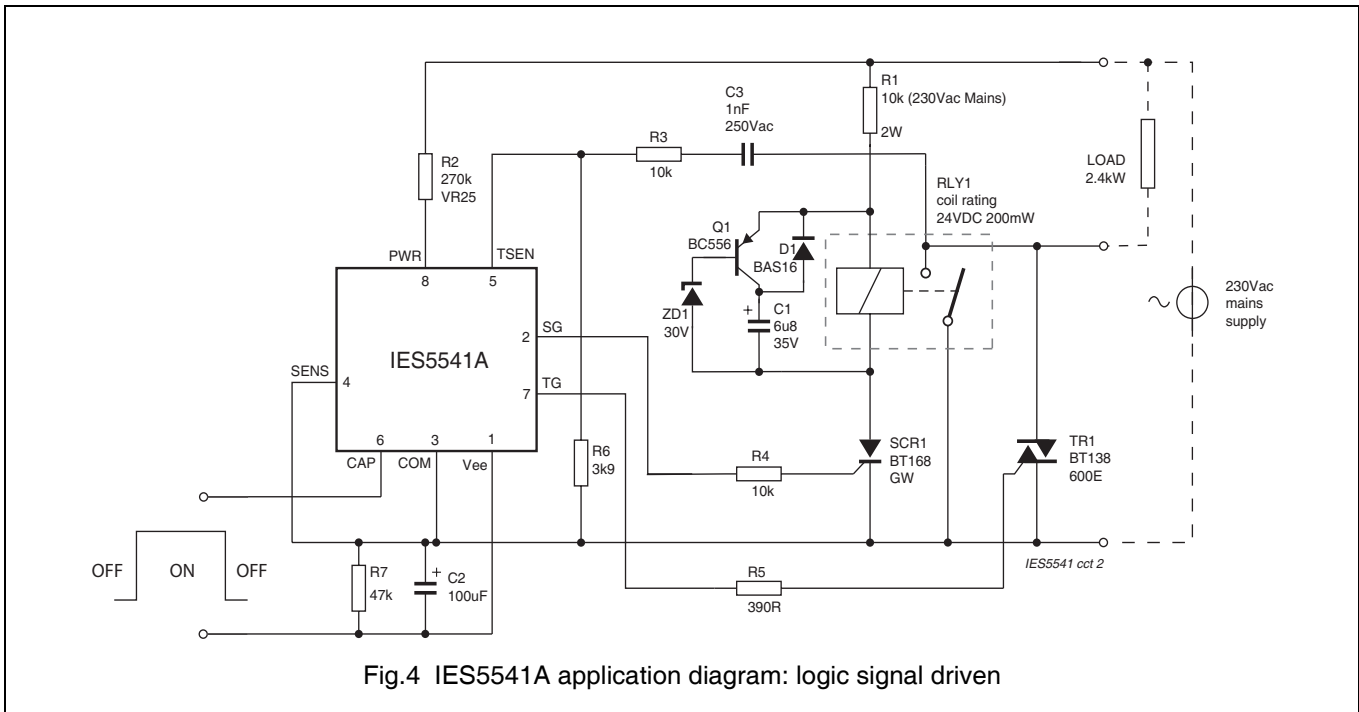
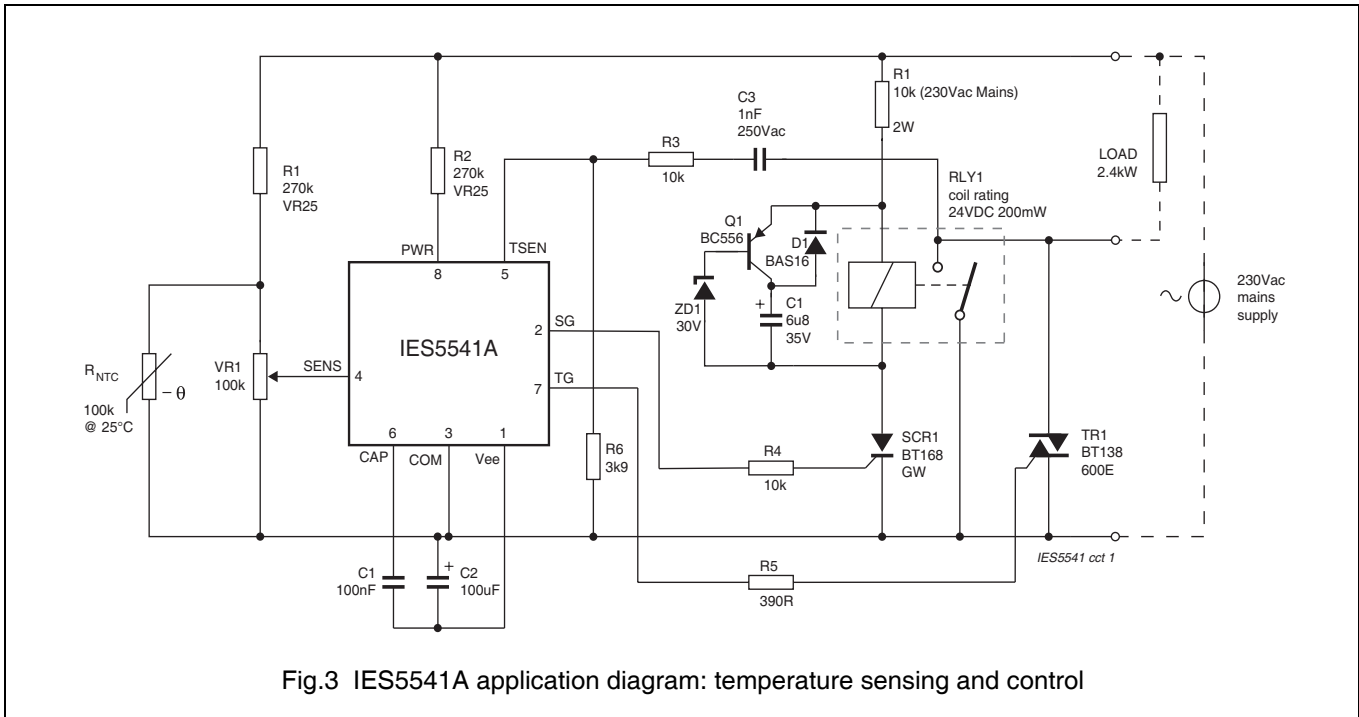

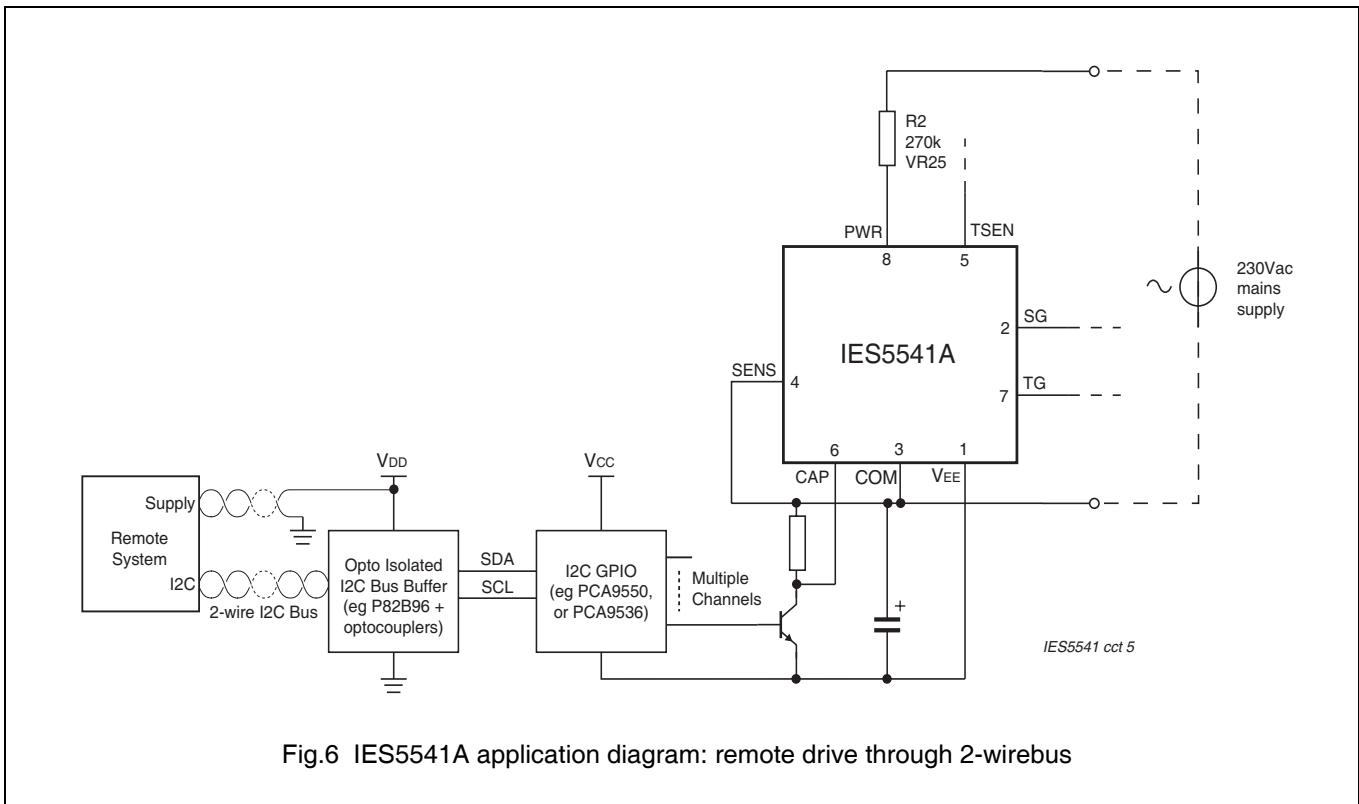
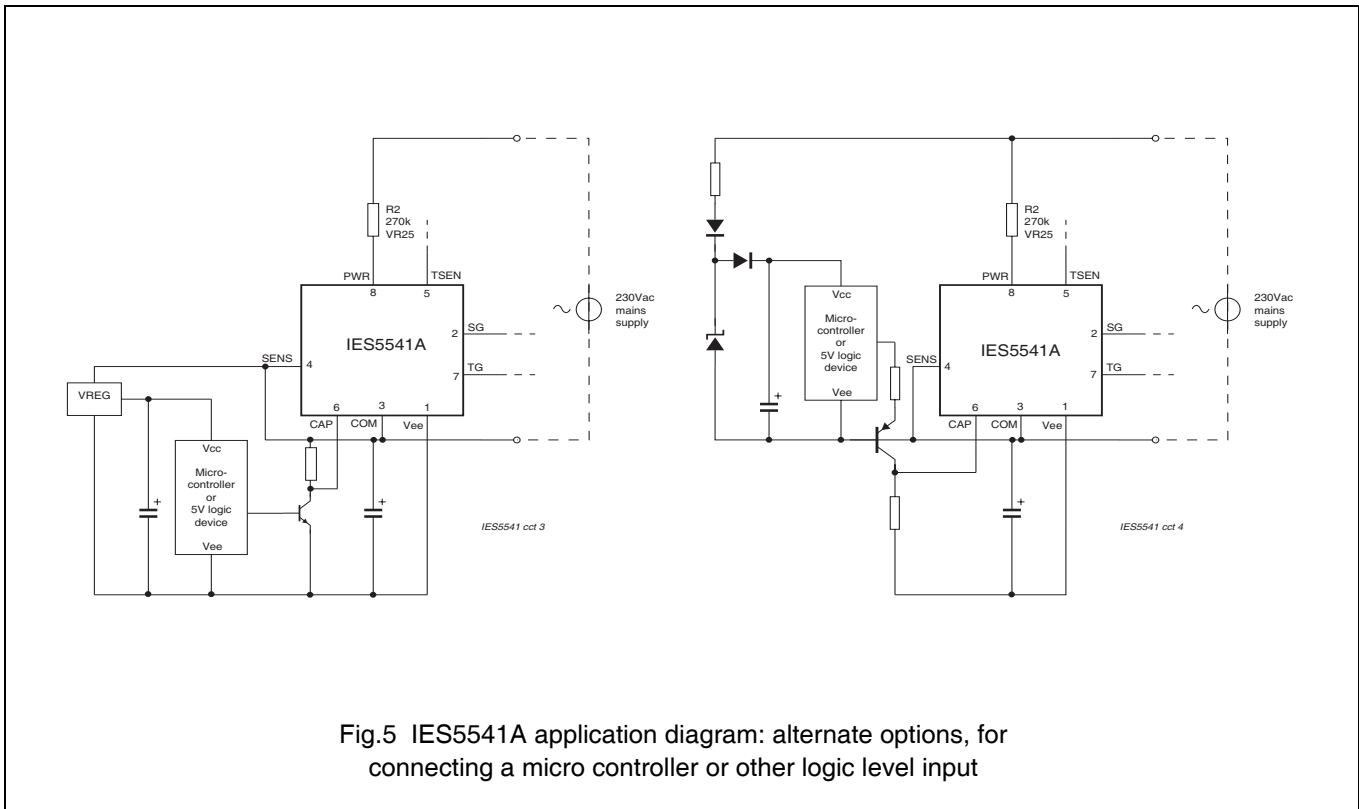

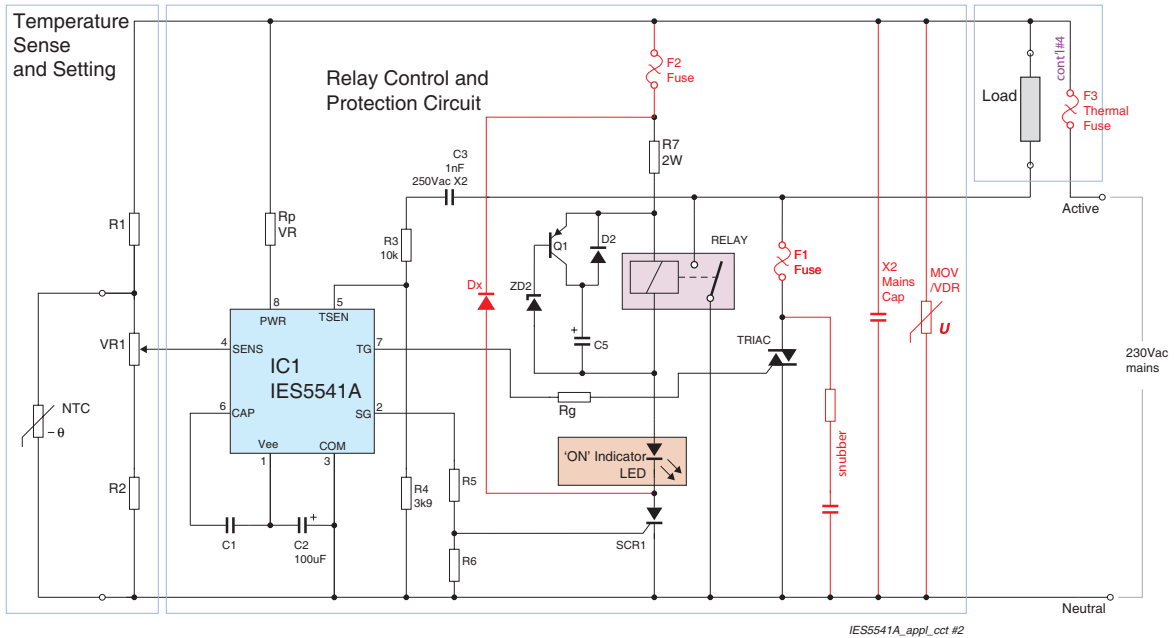

Fig.7 IES5541A application diagram:
Additional components for critical applications, eg failsafe operation,
noisy environments or highly inductive loads

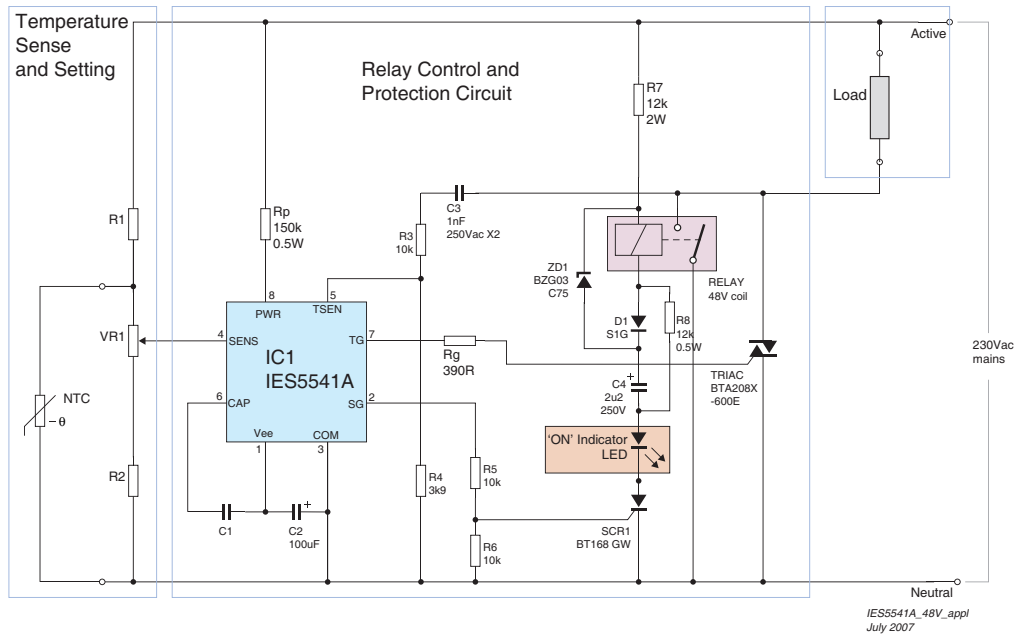



Fig.8 IES5541A application diagram: alternative relay drive for 48V relays

10 ORDERING INFORMATION

TYPE NUMBER	PACKAGE			
	NAME	DESCRIPTION	VERSION	ROHS
IES5541A T	SO8	plastic small outline package; 8 leads; body width 3.9 mm	SOT96-1	Yes 
IES5541A P	DIP8	plastic dual in-line package; 8 leads (300 mil)	SOT97-1	Yes 

Other package options are available - contact Hendon Semiconductors for details. For more information on packages, please refer to the document "Integrated Circuit Packaging and Soldering Information" on the Hendon Semiconductors web site.

11 ESD CAUTION

Electrostatic Discharge (ESD) sensitive device. ESD can cause permanent damage or degradation in the performance of this device. This device contains ESD protection structures aimed at minimising the impact of ESD. However, it is the users responsibility to ensure that proper ESD precautions are observed during the handling, placement and operation of this device.



12 DOCUMENT HISTORY

REVISION	DATE	DESCRIPTION
0.6	20060824	HS Formatting & ESD section
1.0	20070528	Update email address, Correct typos Sect 6.8 & Tables, Release Version
1.1	20070814	Update application circuits, Correct Tables, Release Version

13 DEFINITIONS

Data sheet status	
Engineering sample information	This contains draft information describing an engineering sample provided to demonstrate possible function and feasibility. Engineering samples have no guarantee that they will perform as described in all details.
Objective specification	This data sheet contains target or goal specifications for product development. Engineering samples have no guarantee that they will function as described in all details.
Preliminary specification	This data sheet contains preliminary data; supplementary data may be published later. Products to this data may not yet have been fully tested, and their performance fully documented.
Product specification	This data sheet contains final product specifications.
Limiting values	
Limiting values given are in accordance with the Absolute Maximum Rating System (IEC 134). Stress above one or more of the limiting values may cause permanent damage to the device. These are stress ratings only and operation of the device at these or at any other conditions above those given in the Characteristics sections of the specification is not implied. Exposure to limiting values for extended periods may affect device reliability.	
Application information	
Where application information is given, it is advisory and does not form part of the specification.	

14 COMPANY INFORMATION

HENDON SEMICONDUCTORS a trading name of INTEGRATED ELECTRONIC SOLUTIONS PTY. LTD.
 ABN 17 080 879 616

Postal address:
 Hendon Semiconductors
 PO Box 2226
 Port Adelaide SA 5015
 AUSTRALIA

Street Address:
 Hendon Semiconductors
 1 Butler Drive
 Hendon SA 5014
 AUSTRALIA

Telephone: +61 8 8348 5200
 Facsimile: +61 8 8243 1048
 World Wide Web: www.hendonsemiconductors.com
www.bus-buffer.com
 Email: hendon.info@ies-sa.com.au

15 DISCLAIMER

Integrated Electronic Solutions Pty. Ltd. ABN 17 080 879 616 trading as Hendon Semiconductors (“Hendon”) reserves the right to make changes to both its products and product data without notice.

Hendon makes no warranty, representation or guarantee regarding the suitability of its products for any particular purpose, nor does Hendon assume any liability arising out of the use or application of any Hendon product. Hendon specifically disclaims any and all liability, including without limitation incidental or consequential damages. It is the responsibility of the customer to ensure that in all respects the application in which Hendon goods are used is suited to the purpose of the end user.

Typical performance figures, where quoted may depend on the application and therefore must be validated by the customer in each particular application. It is the responsibility of customers to ensure that any designs using Hendon products comply with good practice, applicable standards and approvals. Hendon accepts no responsibility for incorrect or non-compliant use of its products, failure to meet appropriate standards and approvals in the application of Hendon products, or for the correct engineering choice of other connected components, layout and operation of Hendon products.

Any customer purchasing or using Hendon product(s) for an unintended or unauthorised application shall indemnify and hold Hendon and its officers, employees, related companies, affiliates and distributors harmless against all claims, costs, damages, expenses, and reasonable legal fees arising out of, directly or indirectly, any claim of loss, personal injury or death associated with such unintended or unauthorised use, even if such claim alleges that Hendon was negligent regarding the design or manufacture of the relevant product(s).

Life Support Applications

Products of Hendon Semiconductors (Hendon) are not designed for use in life support appliances, devices or systems, where malfunction can result in personal injury. Customers using or selling Hendon products for use in such applications do so at their own risk and agree to fully indemnify Hendon for any damages resulting from such improper use or sale.

