

High Speed Dual MOSFET Driver

Features

- ▶ 6ns rise and fall time with 1000pF load
- ▶ 2.0A peak output source/sink current
- ▶ 1.2 to 5.0V input CMOS compatible
- ▶ 4.5 to 13V single positive supply voltage
- ▶ Smartlogic threshold
- ▶ Low jitter design
- ▶ Two matched channels
- ▶ Outputs can swing below ground
- ▶ Low inductance package
- ▶ Thermally-enhanced package

Applications

- ▶ Medical ultrasound imaging
- ▶ Piezoelectric transducer drivers
- ▶ Nondestructive evaluation
- ▶ PIN diode driver
- ▶ CCD clock driver/buffer
- ▶ High speed level translator

General Description

The Supertex MD1210 is a high speed, dual MOSFET driver. It is designed to drive high voltage P and N-channel MOSFET transistors for medical ultrasound and other applications requiring a high output current for a capacitive load. The high-speed input stage of the MD1210 can operate from 1.2 to 5.0V logic interface with an optimum operating input signal range of 1.8 to 3.3V. An adaptive threshold circuit is used to set the level translator switch threshold to the average of the input logic 0 and logic 1 levels. The input logic levels may be ground referenced, even though the driver is putting out bipolar signals. The level translator uses a proprietary circuit, which provides DC coupling together with high-speed operation.

VDD1, VDD2, and VH should be connected to the positive supply voltage, and VSS1, VSS2, and VL should be connected to 0V or to Ground. The GND pin is the logic control input signal digital ground. The output stage is capable of peak currents of up to $\pm 2.0A$, depending on the supply voltages used and load capacitance present.

The OE pin serves a dual purpose. First, its logic H level is used to compute the threshold voltage level for the channel input level translators. Secondly, when OE is low, the outputs are disabled, with the A output high and the B output low. This assists in properly pre-charging the AC coupling capacitors that may be used in series in the gate drive circuit of an external PMOS and NMOS transistor pair.

Typical Application Circuit

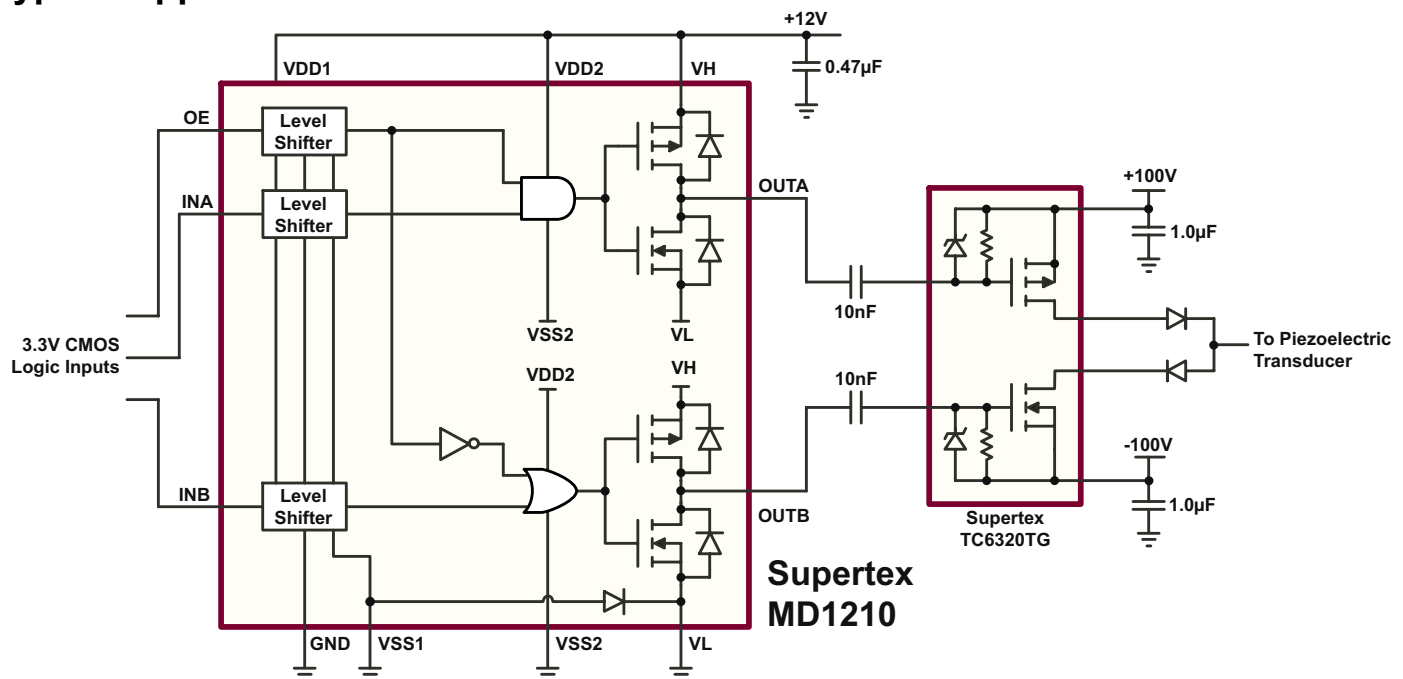

Ordering Information

Device	Package Option
	12-Lead QFN 4.00x4.00mm body 1.00mm height (max) 0.80mm pitch
MD1210	MD1210K6-G

-G indicates package is RoHS compliant ("Green")



Absolute Maximum Ratings

Parameter	Value
V_{DD1}, V_{DD2}, V_H - supply voltage	-0.5V to +13.5V
V_{SS1}, V_{SS2}, V_L - supply voltage	0V
Logic input levels	-0.5V to 7.0V
Maximum junction temperature	+125°C
Storage temperature	-65°C to 150°C
Operating temperature	-20°C to 85°C

Absolute Maximum Ratings are those values beyond which damage to the device may occur. Functional operation under these conditions is not implied. Continuous operation of the device at the absolute rating level may affect device reliability. All voltages are referenced to device ground.

Pin Configuration

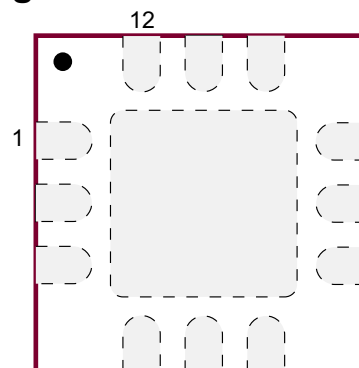

12-Lead QFN (K6)
(top view)

Product Marking

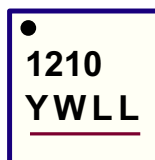

Y = Last Digit of Year Sealed
 W = Code for Week Sealed
 L = Lot Number
 — = "Green" Packaging

Package may or may not include the following marks: Si or

12-Lead QFN (K6)

DC Electrical Characteristics

(Over operating conditions unless otherwise specified, $V_H = V_{DD1} = V_{DD2} = 12V$, $V_L = V_{SS1} = V_{SS2} = 0V$, $V_{OE} = 3.3V$, $T_A = 25^\circ C$)

Sym	Parameter	Min	Typ	Max	Units	Conditions
V_{DD1}, V_{DD2}	Supply voltage	4.5	-	13	V	---
V_H	Output high supply voltage	$V_{SS} + 2.0$	-	V_{DD}	V	---
V_L	Output low supply voltage	0	-	$V_{DD} - 2.0$	V	---
I_{DD1Q}	V_{DD1} quiescent current	-	0.55	-	mA	No input transitions
I_{DD2Q}	V_{DD2} quiescent current	-	-	10	μA	
I_{HQ}	V_H quiescent current	-	-	10	μA	
I_{DD1}	V_{DD1} average current	-	0.88	-	mA	One channel on at 5.0Mhz, No load
I_{DD2}	V_{DD2} average current	-	6.6	-	mA	
I_H	V_H average current	-	23	-	mA	
V_{IH}	Input logic voltage high	$V_{OE} - 0.3$	-	5.0	V	For logic inputs INA and INB
V_{IL}	Input logic voltage low	0	-	0.3	V	
I_{IH}	Input logic current high	-	-	1.0	μA	
I_{IL}	Input logic current low	-	-	1.0	μA	

DC Electrical Characteristics (cont.)(Over operating conditions unless otherwise specified, $V_H = V_{DD1} = V_{DD2} = 12V$, $V_L = V_{SS1} = V_{SS2} = 0V$, $V_{OE} = 3.3V$, $T_A = 25^\circ C$)

Sym	Parameter	Min	Typ	Max	Units	Conditions
V_{IH}	OE Input logic voltage high	1.2	-	5.0	V	For logic input OE
V_{IL}	OE Input logic voltage low	0	-	0.3	V	
R_{IN}	OE input logic impedance to GND	12	20	30	K Ω	
C_{IN}	Logic input capacitance	-	5.0	10	pF	All inputs
θ_{JA}	Thermal resistance to air	-	47	-	$^\circ C/W$	1oz. 4-layer 3x4" PCB with thermal pad and thermal via array
θ_{JC}	Thermal resistance to case	-	7.0	-	$^\circ C/W$	---

Outputs ($V_H = V_{DD1} = V_{DD2} = 12V$, $V_L = V_{SS1} = V_{SS2} = 0V$, $V_{OE} = 3.3V$, $T_A = 25^\circ C$)

Sym	Parameter	Min	Typ	Max	Units	Conditions
R_{SINK}	Output sink resistance	-	-	12.5	Ω	$I_{SINK} = 50mA$
R_{SOURCE}	Output source resistance	-	-	12.5	Ω	$I_{SOURCE} = 50mA$
I_{SINK}	Peak output sink current	-	2.0	-	A	---
I_{SOURCE}	Peak output source current	-	2.0	-	A	---

AC Electrical Characteristics ($V_H = V_{DD1} = V_{DD2} = 12V$, $V_L = V_{SS1} = V_{SS2} = 0V$, $V_{OE} = 3.3V$, $T_A = 25^\circ C$)

Sym	Parameter	Min	Typ	Max	Units	Conditions
t_{irf}	Inputs or OE rise & fall time	-	-	10	ns	Logic input edge speed requirement
t_{PLH}	Propagation delay when output is from low to high	-	7.0	-	ns	$C_{LOAD} = 1000pF$, see timing diagram Input signal rise/fall time of 2ns
t_{PHL}	Propagation delay when output is from high to low	-	7.0	-	ns	
t_{POE}	Propagation delay OE to outputs	-	9.0	-	ns	
t_r	Output rise time	-	6.0	-	ns	
t_f	Output fall time	-	6.0	-	ns	
$ t_r - t_f $	Rise and fall time matching	-	1.0	-	ns	
$ t_{PLH} - t_{PHL} $	Propagation low to high and high to low matching	-	1.0	-	ns	
Δt_{dm}	Propagation delay match	-	± 2.0	-	ns	Device to device delay match

Logic Truth Table

Logic Inputs			Output	
OE	INA	INB	OUTA	OUTB
H	L	L	V_H	V_H
H	L	H	V_H	V_L
H	H	L	V_L	V_H
H	H	H	V_L	V_L
L	X	X	V_H	V_L

Timing Diagram

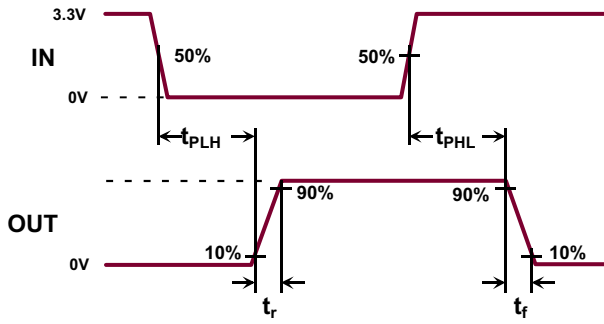

Simplified Block Diagram

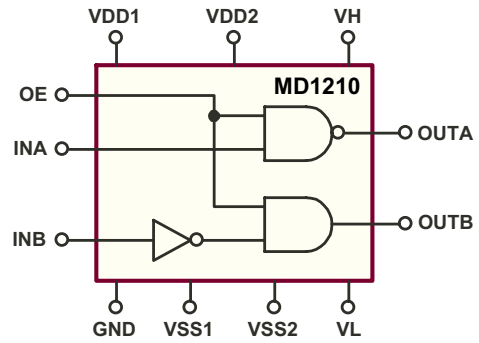

Propagation Delay

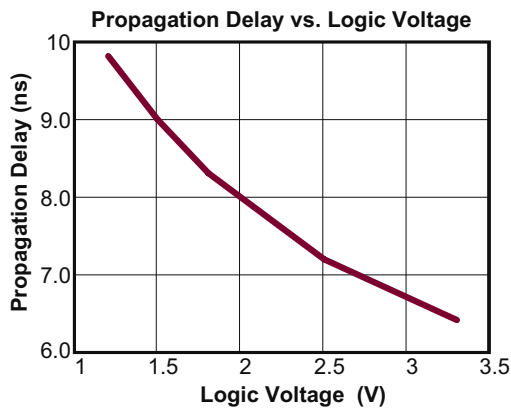

Logic Input Threshold

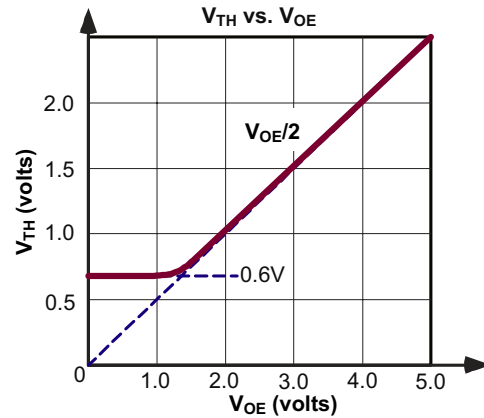

Detailed Block Diagram

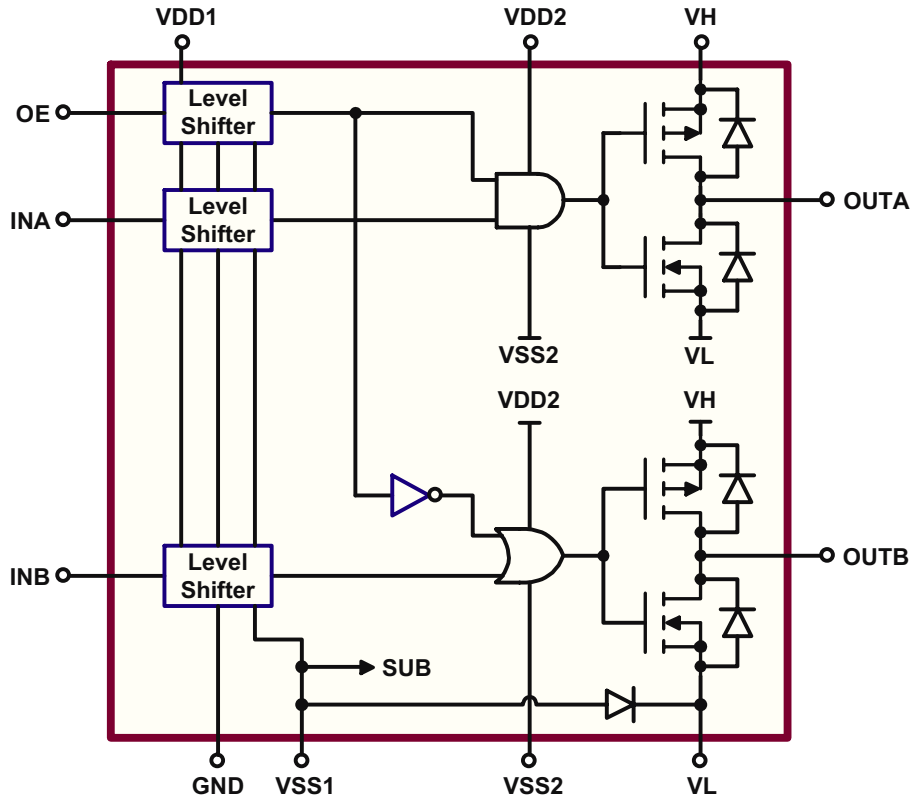

Application Information

For proper operation of the MD1210, low inductance bypass capacitors should be used on the various supply pins. The GND input pin should be connected to the digital ground. The INA, INB, and OE pins should be connected to their logic source with a swing of GND to logic level high, which is 1.2V to 5.0V. Good trace practices should be followed corresponding to the desired operating speed. The internal circuitry of the MD1210 is capable of operating up to 100MHz, with the primary speed limitation being the loading effects of the load capacitance. Because of this speed and the high transient currents that result with capacitive loads, the bypass capacitors should be as close to the chip pins as possible. The VSS1, VSS2, and VL pins should have low inductance feed-through connections directly to a ground plane. The power connections VDD1 and VDD2 should have a ceramic bypass capacitor to the ground plane with short leads and decoupling components to prevent resonance in the power leads. A common capacitor and voltage source may be used for these two pins, which should always have the same DC voltage applied. For applications sensitive to jitter and noise, separate decoupling networks may be used for VDD1 and VDD2.

The VH and VL pins can draw fast transient currents of up to 2.0A, so they should be provided with an appropriate bypass capacitor located next to the chip pins. A ceramic capacitor of up to 1.0 μ F may be appropriate, with a series ferrite bead to prevent resonance in the power supply lead coming to the capacitor. Pay particular attention to minimizing trace lengths and using sufficient trace width to reduce inductance. Surface mount components are highly recommended. Since the output impedance of this driver is very low, in some cases it may be desirable to add a small series resistor in series with the output signal to obtain better waveform integrity at the load terminals. This will of course reduce the output voltage slew rate at the terminals of a capacitive load.

Pay particular attention to the parasitic coupling from the driver output to the input signal terminals. This feedback may cause oscillations or spurious waveform shapes on the edges of signal transitions. Since the input operates with signals down to 1.2V even small coupled voltages may cause problems. Use of a solid ground plane and good power and signal layout practices will prevent this problem. Be careful that the circulating ground return current from a capacitive load cannot react with common inductance to cause noise voltages in the input logic circuitry.

Pin Description

Pin	Name	Description
1	INA	Logic input. Controls OUTA when OE is high. Input logic high will cause the output to swing to VL. Input logic low will cause the output to swing to VH.
2	VL	Supply voltage for N-channel output stage.
3	INB	Logic input. Controls OUTB when OE is high. Input logic high will cause the output to swing to VL. Input logic low will cause the output to swing to VH.
4	GND	Logic input ground reference.
5	VSS1	Low side analog circuit and level shifter supply voltage. Should be at the same potential as VSS2.
6	VSS2	Low side gate drive supply voltage.
7	OUTB	Output driver. Swings from VH to VL. Intended to drive the gate of an external N-channel MOSFET via a series capacitor. When OE is low, the output is disabled. OUTB will swing to VL turning off the external N-channel MOSFET.
8	VH	Supply voltage for P-channel output stage.
9	OUTA	Output driver. Swings from VH to VL. Intended to drive the gate of an external P-channel MOSFET via a series capacitor. When OE is low, the output is disabled. OUTA will swing to VH turning off the external P-channel MOSFET.
10	VDD2	High side gate drive supply voltage.
11	VDD1	High side analog circuit and level shifter supply voltage. Should be at the same potential as VDD2.
12	OE	Output-enable logic input. When OE is high, $(V_{OE} + V_{GND})/2$ sets the threshold transition (between logic level high and low for INA and INB). When OE is low, OUTA is at VH and OUTB is at VL regardless of INA and INB.

Notes:

1. Thermal Pad and Pin #5 (VSS1) must be connected externally.
2. Index Pad and Thermal Pad are connected internally

12-Lead QFN Package Outline (K6)

4.00x4.00mm body, 1.00mm height (max), 0.80mm pitch

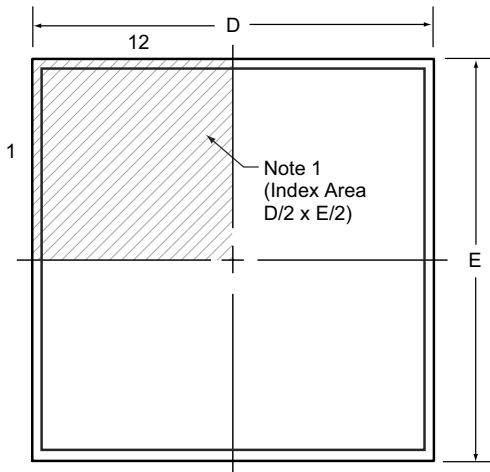

Top View

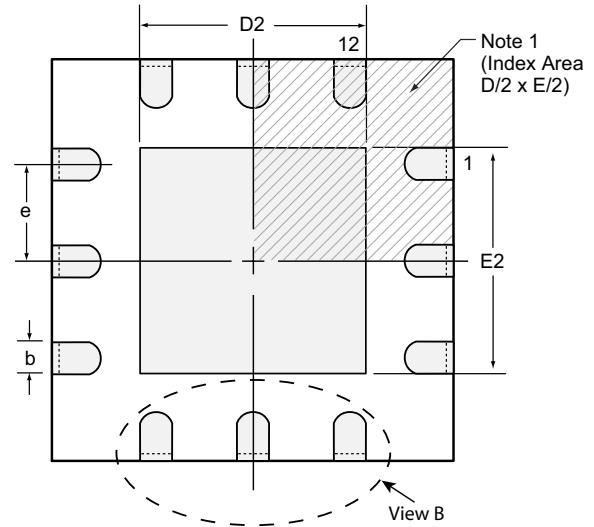

Bottom View

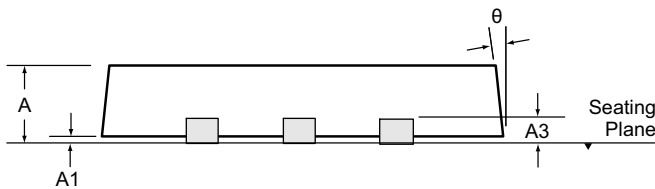

Side View

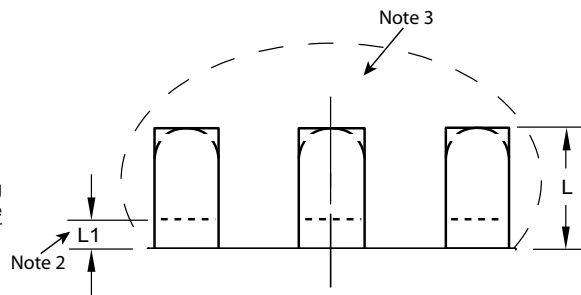

View B

Notes:

1. A Pin 1 identifier must be located in the index area indicated. The Pin 1 identifier can be: a molded mark/identifier; an embedded metal marker; or a printed indicator.
2. Depending on the method of manufacturing, a maximum of 0.15mm pullback (L1) may be present.
3. The inner tip of the lead may be either rounded or square.

Symbol	A	A1	A3	b	D	D2	E	E2	e	L	L1	θ	
Dimension (mm)	MIN	0.80	0.00	0.20 REF	0.25	3.85*	0.75	3.85*	0.75	0.80 BSC	0.35	0.00	0°
	NOM	0.90	0.02		0.30	4.00	1.70	4.00	1.70		0.55	-	-
	MAX	1.00	0.05		0.35	4.15*	2.25	4.15*	2.25		0.75	0.15	14°

JEDEC Registration MO-220, Variation VGGB, Issue K, June 2006.

* This dimension is not specified in the JEDEC drawing.

Drawings not to scale.

Supertex Doc. #: DSPD-12QFNK64X4P080, Version C041309.

(The package drawing(s) in this data sheet may not reflect the most current specifications. For the latest package outline information go to <http://www.supertex.com/packaging.html>.)

Supertex inc. does not recommend the use of its products in life support applications, and will not knowingly sell them for use in such applications unless it receives an adequate "product liability indemnification insurance agreement." Supertex inc. does not assume responsibility for use of devices described, and limits its liability to the replacement of the devices determined defective due to workmanship. No responsibility is assumed for possible omissions and inaccuracies. Circuitry and specifications are subject to change without notice. For the latest product specifications refer to the Supertex inc. website: <http://www.supertex.com>.