

800mA Low Dropout Voltage Regulator

FEATURES

- Guaranteed 0.8A Output Current
- Guaranteed 1A Peak Current
- Three Terminal Adjustable or Fixed 1.5V, 1.8V, 2.5V, 2.85V, 3.0V, 3.3V and 5V
- Low Quiescent Current
- Low Dropout Voltage of 1.1V at 0.8A
- 0.1% Line and 0.2% Load Regulation
- Stable with 2.2 μ F Ceramic Capacitor
- Overcurrent and Thermal Protection
- Lead Free, RoHS Compliant Packages: SOT-223, TO-252, TO-220, and TO-263

APPLICATIONS

- Desktop PC's Servers
- SCSI-II Active Terminator
- Portable/ Palm Top / Notebook Computers
- Cordless Phones
- Battery Chargers
- Disk Drives
- Portable Consumer Equipment
- Portable Instrumentation
- SMPS Post-Regulator

DESCRIPTION

The SPX1117 is a low power positive-voltage regulator designed to satisfy moderate power requirements with a cost effective, small footprint solution. This device is an excellent choice for use in battery-powered applications and portable computers. The SPX1117 features very low quiescent current and a low dropout voltage of 1.1V at a full load. As output current decreases, quiescent current flows into the load, increasing efficiency. SPX1117 is available in adjustable or fixed 1.5V, 1.8V, 2.5V, 2.85V, 3.0V, 3.3V and 5V output voltages.

The SPX1117 is offered in several 3-pin surface mount packages: SOT-223, TO-252, TO-220 and TO-263. An output capacitor of 10 μ F provides unconditional stability while a smaller 2.2 μ F capacitor is sufficient for most applications.

FUNCTIONAL DIAGRAM

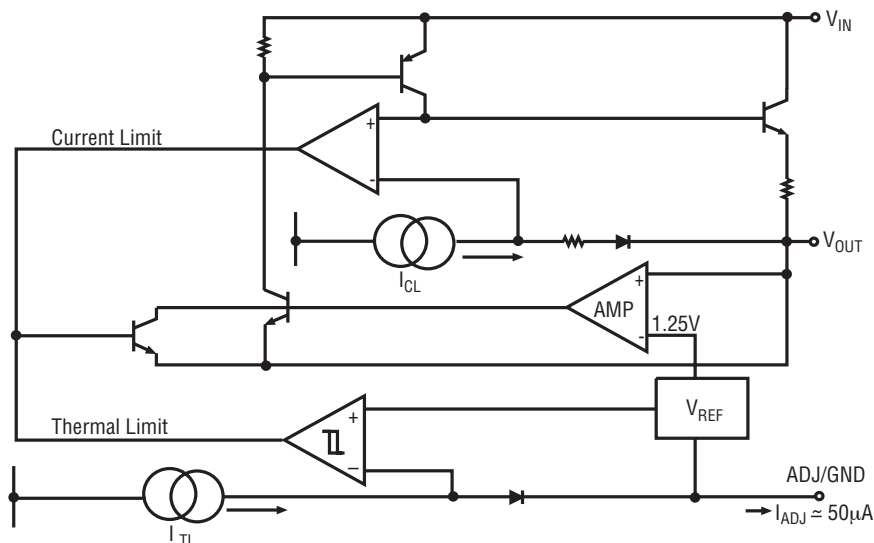

ABSOLUTE MAXIMUM RATINGS

Power Dissipation.....Internally Limited
 Lead Temperature (soldering, 5 seconds)260°C
 Storage Temperature Range.....-65°C to +150°C
 Operating Junction Temperature Range.....-40°C to +125°C
 Input Supply Voltage +20V
 Input to Output Voltage 18.8V
 ESD Rating.....2kV min

These are stress ratings only and functional operation of the device at these ratings or any other above those indicated in the operation sections of the specifications below is not implied. Exposure to absolute maximum rating conditions for extended periods of time may affect reliability.

ELECTRICAL CHARACTERISTICS

$T_A = 25^\circ\text{C}$, $C_{IN} = C_{OUT} = 10\mu\text{F}$, unless otherwise specified. The Boldface applies over the full operating temperature range.

PARAMETER	CONDITIONS	MIN	TYP	MAX	UNITS
1.5V Version					
Output Voltage	$I_{OUT} = 5\text{mA}$, $V_{IN} = 3.0\text{V}$, $T_J = 25^\circ\text{C}$ $5\text{mA} \leq I_{OUT} \leq 800\text{mA}$, $2.9\text{V} \leq V_{IN} \leq 10\text{V}$	1.485 1.470	1.500	1.515 1.530	V
1.8V Version					
Output Voltage	$I_{OUT} = 5\text{mA}$, $V_{IN} = 3.3\text{V}$, $T_J = 25^\circ\text{C}$ $5\text{mA} \leq I_{OUT} \leq 800\text{mA}$, $3.2\text{V} \leq V_{IN} \leq 10\text{V}$	1.782 1.764	1.800	1.818 1.836	V
2.5V Version					
Output Voltage	$I_{OUT} = 5\text{mA}$, $V_{IN} = 4.0\text{V}$, $T_J = 25^\circ\text{C}$ $5\text{mA} \leq I_{OUT} \leq 800\text{mA}$, $3.9\text{V} \leq V_{IN} \leq 10\text{V}$	2.475 2.450	2.500	2.525 2.550	V
2.85V Version					
Output Voltage	$I_{OUT} = 5\text{mA}$, $V_{IN} = 4.35\text{V}$, $T_J = 25^\circ\text{C}$ $5\text{mA} \leq I_{OUT} \leq 800\text{mA}$, $4.25\text{V} \leq V_{IN} \leq 10\text{V}$	2.821 2.793	2.850	2.878 2.907	V
3.00V Version					
Output Voltage	$I_{OUT} = 5\text{mA}$, $V_{IN} = 4.5\text{V}$, $T_J = 25^\circ\text{C}$ $5\text{mA} \leq I_{OUT} \leq 800\text{mA}$, $4.4\text{V} \leq V_{IN} \leq 10\text{V}$	2.970 2.940	3.000	3.030 3.060	V
3.30V Version					
Output Voltage	$I_{OUT} = 5\text{mA}$, $V_{IN} = 4.8\text{V}$, $T_J = 25^\circ\text{C}$ $5\text{mA} \leq I_{OUT} \leq 800\text{mA}$, $4.7\text{V} \leq V_{IN} \leq 10\text{V}$	3.267 3.234	3.300	3.333 3.366	V
5V Version					
Output Voltage	$I_{OUT} = 5\text{mA}$, $V_{IN} = 6.5\text{V}$ $5\text{mA} \leq I_{OUT} \leq 800\text{mA}$, $6.4\text{V} \leq V_{IN} \leq 12\text{V}$	4.950 4.90	5	5.050 5.10	V
All Voltage Options					
Reference Voltage	$I_{OUT} = 5\text{mA}$, $(V_{IN} - V_{OUT}) = 2\text{V}$, $T_J = 25^\circ\text{C}$ $5\text{mA} \leq I_{OUT} \leq 800\text{mA}$, $1.4\text{V} \leq (V_{IN} - V_{OUT}) \leq 10\text{V}$	1.238 1.225	1.250	1.262 1.270	V
Output Voltage Temperature Stability			0.3		%
Line Regulation (Note 1)	$V_{INMIN} \leq V_{IN} \leq 12\text{V}$, $V_{OUT} = \text{Fixed/Adj}$, $I_{OUT} = 5\text{mA}$		3	7	mV
Load Regulation (Note 1)	$5\text{mA} \leq I_{OUT} \leq 800\text{mA}$, $V_{OUT} = \text{Fixed/Adj}$		6	12	mV
Dropout Voltage (Note 2)	$I_{OUT} = 100\text{mA}$ $I_{OUT} = 500\text{mA}$ $I_{OUT} = 800\text{mA}$		1.00 1.05 1.10	1.20 1.25 1.30	V
Quiescent Current	$4.25\text{V} \leq V_{IN} \leq 6.5\text{V}$		5	10	mA

ELECTRICAL CHARACTERISTICS

$T_A = 25^\circ\text{C}$, $C_{IN} = C_{OUT} = 10\mu\text{F}$, unless otherwise specified. The Boldface applies over the full operating temperature range.

PARAMETER	CONDITIONS	MIN	TYP	MAX	UNITS
Adjust Pin Current			50	120	μA
Current Limit	$(V_{IN} - V_{OUT}) = 5\text{V}$	1.0	1.5	2.0	A
Thermal Regulation	25°C , 30mS pulse		0.01	0.1	%/W
Ripple Rejection	$f_{\text{RIPPLE}} = 120\text{Hz}$, $(V_{IN} - V_{OUT}) = 2\text{V}$, $V_{\text{RIPPLE}} = 1\text{V}_{\text{PP}}$	60	75		dB
Long Term Stability	125°C , 1000Hrs		0.03		%
RMS Output Noise	% of V_{OUT} , $10\text{Hz} \leq f \leq 10\text{kHz}$		0.003		%

*Note 1 - For fixed option, $V_{\text{INMIN}} = V_{\text{OUT}} + 1.5\text{V}$
 - For adjustable option, $V_{\text{INMIN}} = V_{\text{IN}} - V_{\text{OUT}} = 1.4\text{V}$

*Note 2 - Dropout voltage is the input voltage minus output voltage that produces a 1% decrease in output voltage with respect to the nominal output voltage at $V_{\text{IN}} = V_{\text{OUT}} + 1.5\text{V}$

TYPICAL PERFORMANCE CHARACTERISTICS

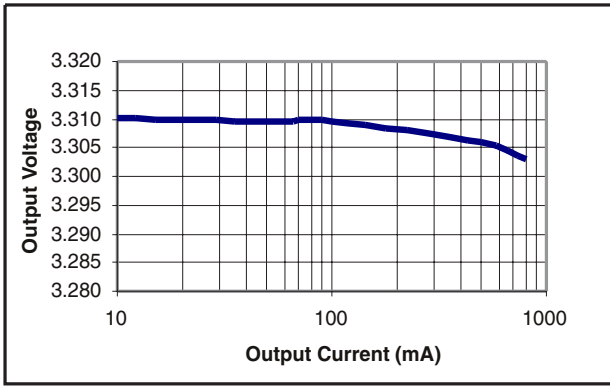

Figure 1. Load Regulation for SPX1117M3-3.3;
 $V_{IN}=4.8V$

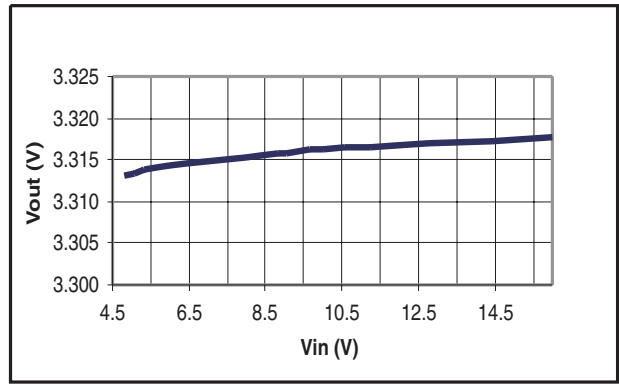

Figure 2. Line Regulation for SPX1117M3-3.3;
 $I_{OUT}=10mA$

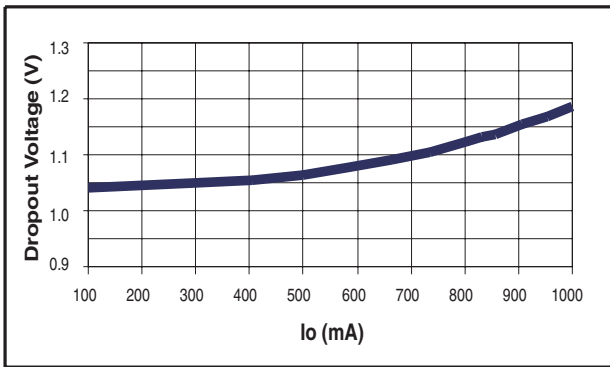

Figure 3. Dropout Voltage vs Output Current for SPX1117M3-3.3; $V_{IN}=4.8V$, $C_{OUT}=2.2\mu F$

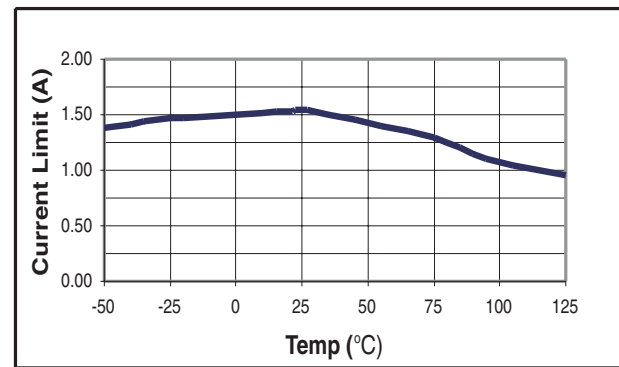

Figure 4. Current Limit for SPX1117M3-3.3; $V_{IN}=4.8V$,
 $C_{IN}=C_{OUT}=1\mu F$, I_{OUT} pulsed from 10mA to Current Limit

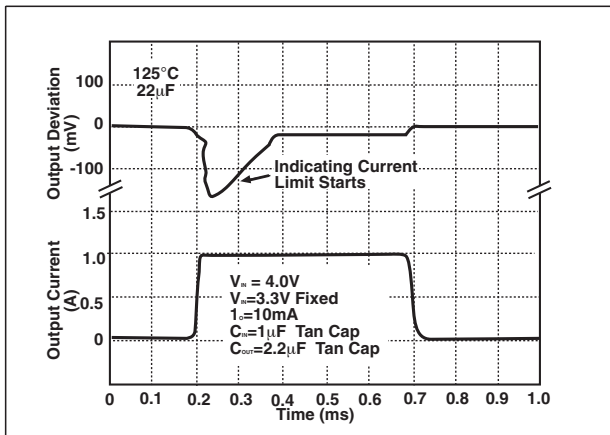

Figure 5. Current Limit for SPX1117M3-3.3, Output Voltage Deviation with $I_{OUT}=10mA$ to 1A Step

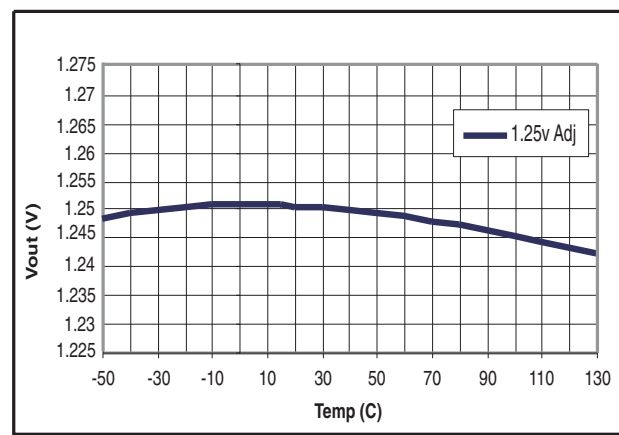

Figure 6. V_{OUT} vs Temperature, $V_{IN}=2.5V$, $I_{OUT}=10mA$

TYPICAL PERFORMANCE CHARACTERISTICS: Continued

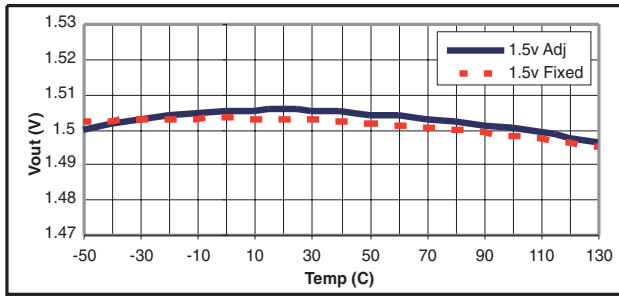

Figure 7. $V_{IN}=3.0V$, $I_{OUT}=10mA$

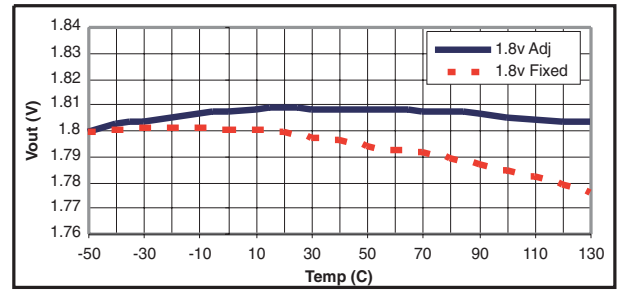

Figure 8. $V_{IN}=3.3V$, $I_{OUT}=10mA$

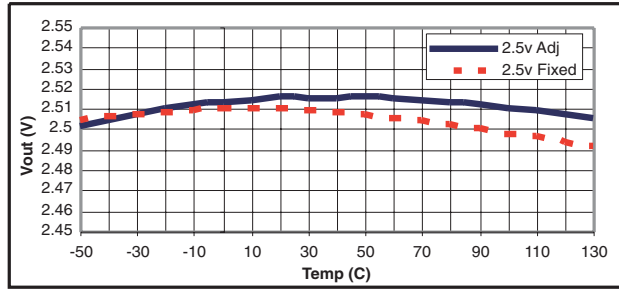

Figure 9. $V_{IN}=4.0V$, $I_{OUT}=10mA$

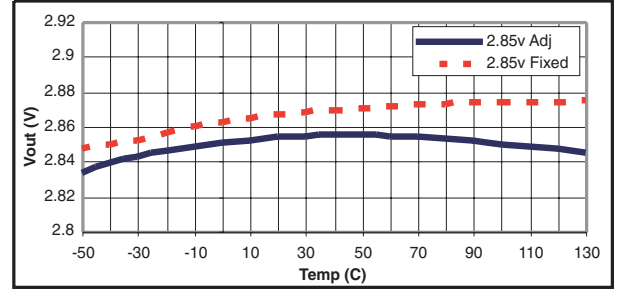

Figure 10. $V_{IN}=4.85V$, $I_{OUT}=10mA$

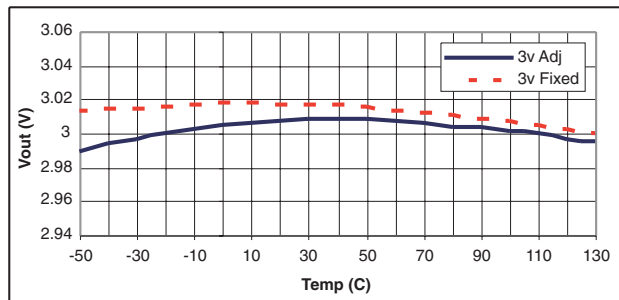

Figure 11. $V_{IN}=4.85V$, $I_{OUT}=10mA$

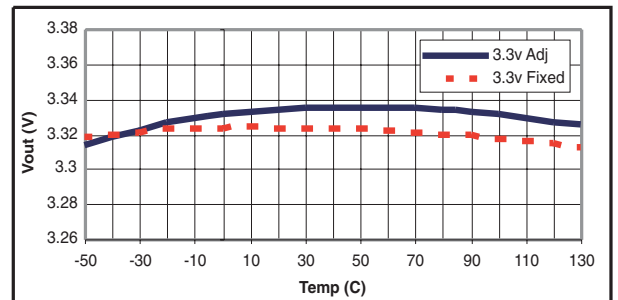

Figure 12. $V_{IN}=5.0V$, $I_{OUT}=10mA$

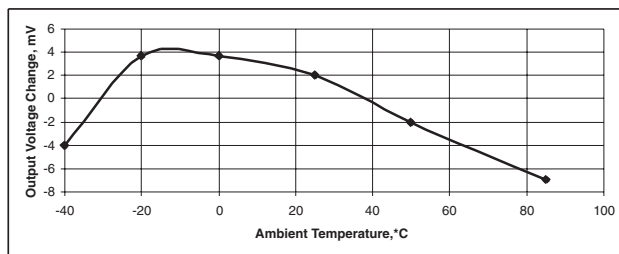

Figure 13. Line Regulation vs Temperature. $V_{OUT}=1.8V$ (adjustable), $V_{IN}=3.3V$

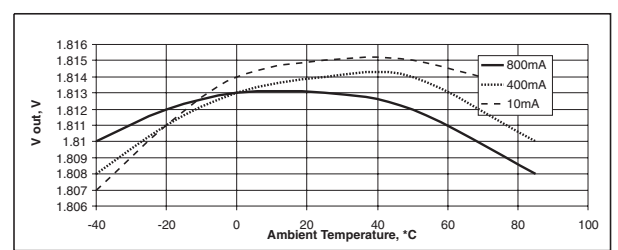

Figure 14. Output Voltage vs Temperature at different Current Loads, $V_{IN}=3.3V$, $V_{OUT}=1.8V$ Adjustable

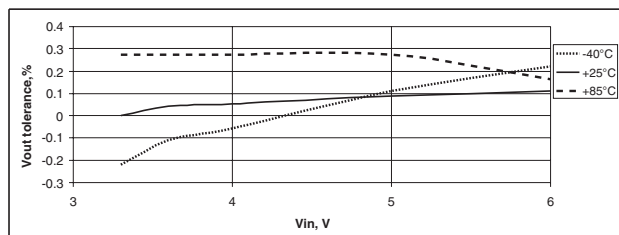

Figure 15. Line Regulation at $I_{LOAD}=800mA$ over Temperature, $V_{OUT}=1.8V$ adjustable

Output Capacitor

To ensure the stability of the SPX1117, an output capacitor of at least 2.2 μ F (tantalum or ceramic) or 10 μ F (aluminum) is required. The value may change based on the application requirements of the output load or temperature range. The value of ESR can vary based on the type of capacitor used in the applications to guarantee stability. The recommended value for ESR is 0.5 Ω or less. A larger value of output capacitance (up to 100 μ F) can improve the load transient response.

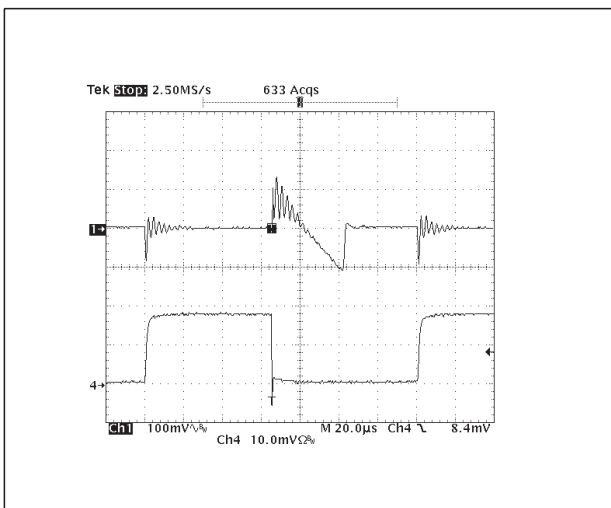
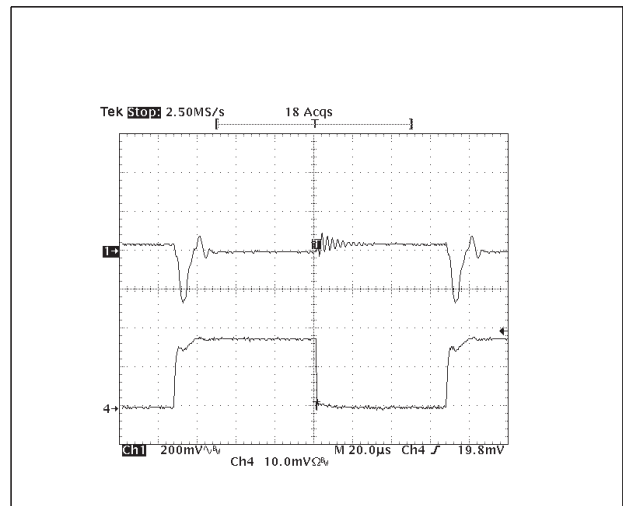

Figure 16. Load Step Response (0 to 800mA), $V_{in}=3.3V$, $V_{out}=1.8V$, $C_{in}=10\mu F$, $C_{out}=2.2\mu F$, Ceramic; 1 = V_{out} , 4 = I_{load}

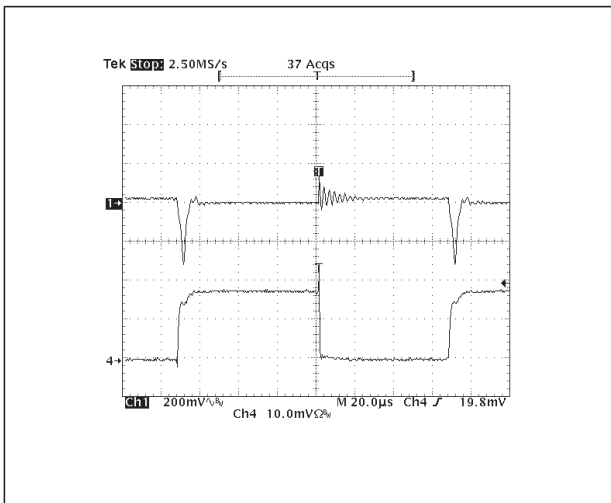

Figure 17. Load Step Response (0 to 800mA), $V_{in}=3.3V$, $V_{out}=1.8V$, $C_{in}=10\mu F$, $C_{out}=2.2\mu F$, OSCON; 1 = V_{out} , 4 = I_{load}

Soldering Methods

The SPX1117 SOT-223 package is designed to be compatible with infrared reflow or vapor-phase reflow soldering techniques. During soldering, the non-active or mildly active fluxes may be used. The SPX1117 die is attached to the heatsink lead which exits opposite the input, output, and ground pins.

Hand soldering and wave soldering should be avoided since these methods can cause damage to the device with excessive thermal gradients on the package. The SOT-223 recommended soldering method are as follows: vapor phase reflow and infrared reflow with the component preheated to within 65°C of the soldering temperature range.

Thermal Characteristics

The thermal resistance of SPX1117 (SOT-223 Package) is 15°C/W from junction to tab and 31 °C/W from tab to ambient for a total of 46 °C/W from junction to ambient (Table 1). The SPX1117 features the internal thermal limiting to protect the device during overload conditions. Special care needs to be taken during continuous load conditions such that the maximum junction temperature does not exceed 125 °C. Thermal protection is activated at >155°C and deactivated at <140 °C.

Taking the FR-4 printed circuit board and 1/16 thick with 1 ounce copper foil as an experiment (fig.13), the PCB material is effective at transmitting heat with the tab attached to the pad area and a ground plane layer on the backside of the substrate. Refer to table 1 for the results of the experiment.

The thermal interaction from other components in the application can effect the thermal resistance of the SPX1117. The actual thermal resistance can be determined with experimentation.

SPX1117 power dissipation is calculated as follows:

$$P_D = (V_{IN} - V_{OUT})(I_{OUT})$$

Maximum Junction Temperature range:
 $T_J = T_A(max) + P_D * \text{thermal resistance}$
 (junction-to-ambient)

Maximum junction temperature must not exceed the 125°C.

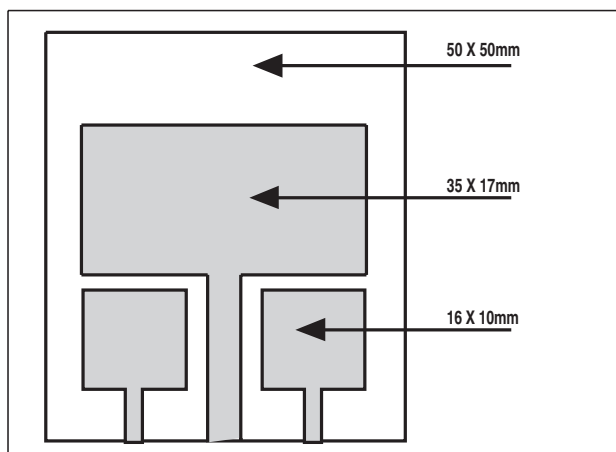

Figure 19. Substrate Layout for SOT-223

Ripple Rejection

Ripple rejection can be improved by adding a capacitor between the ADJ pin and ground as shown in Figure 23. When ADJ pin bypassing is used, the value of the output capacitor required increases to its maximum. If the ADJ pin is not bypassed, the value of the output capacitor can be lowered to 10µF for an electrolytic aluminum capacitor or 2.2µF for a ceramic or solid tantalum capacitor (Fig 22).

However the value of the ADJ-bypass capacitor should be chosen with respect to the following equation:

$$C = 1 / (6.28 * F_R * R_1)$$

Where

- C = value of the capacitor in Farads (select an equal or larger standard value),
- F_R = ripple frequency in Hz,
- R₁ = value of resistor R1 in Ohms.

If an ADJ-bypass capacitor is used, the amplitude of the output ripple will be independent of the output voltage. If an ADJ-bypass capacitor is not used, the output ripple will be proportional to the ratio of the output voltage to the reference voltage:

$$M = V_{OUT} / V_{REF}$$

Where M = multiplier for the ripple seen when the ADJ pin is optimally bypassed.

$$V_{REF} = 1.25V$$

Ripple rejection for the adjustable version is shown in Figure 20.

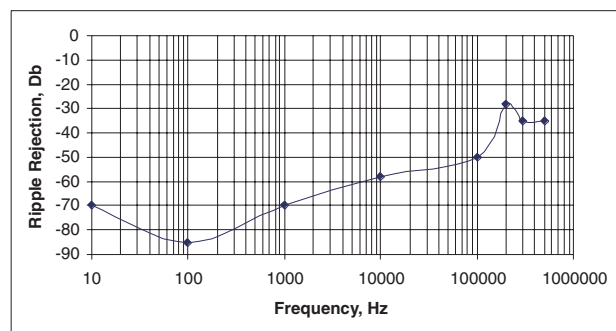

Figure 20. Ripple Rejection; Vin=3.3V, Vout=1.8V (adj.), Iload=200mA

TABLE 1

PC BOARD mm ²	TOPSIDE COPPER mm ²	BACKSIDE COPPER mm ²	THERMAL RESISTANCE JUNC. TO AMB. °C/W
2500	2500	2500	46
2500	1250	2500	47
2500	950	2500	49
2500	2500	0	51
2500	1800	0	53
1600	600	1600	55
2500	1250	0	58
2500	915	0	59
1600	600	0	67
900	240	900	72
900	240	0	85

Output Voltage

The output of the adjustable regulator can be set to any voltage between 1.25V and 15V. The value of V_{OUT} can be quickly approximated using the formula

$$V_{OUT} = 1.25 * (R_1 + R_2) / R_1.$$

A small correction to this formula is required depending on the values of resistors R₁ and R₂, since the adjustable pin current (approx 50µA) flows through R₂. When I_{ADJ} is taken into account, the formula becomes

$$V_{OUT} = V_{REF} (1 + (R_2 / R_1)) + I_{ADJ} * R_2,$$

where

$$V_{REF} = 1.25V.$$

Layout Considerations

Parasitic line resistance can degrade load regulation. In order to avoid this, connect R₁ directly to V_{OUT} as illustrated in Figure 25. For the same reason, R₂ should be connected to the negative side of the load.

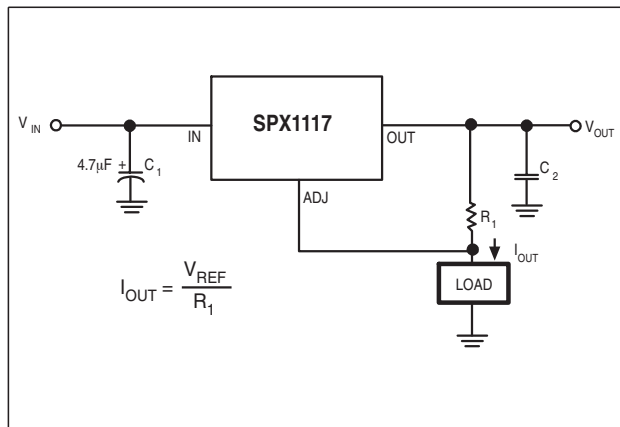

Figure 21. Current Source

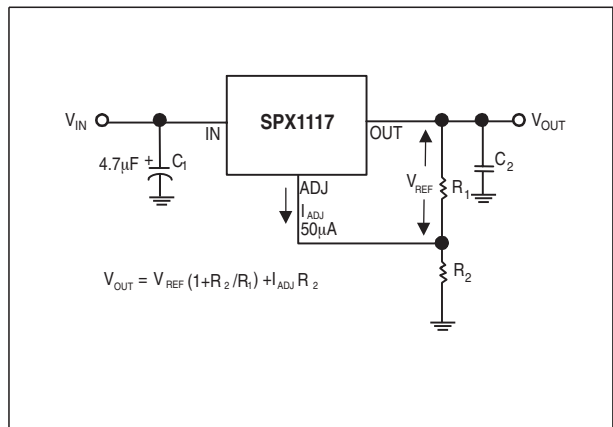

Figure 22. Typical Adjustable Regulator

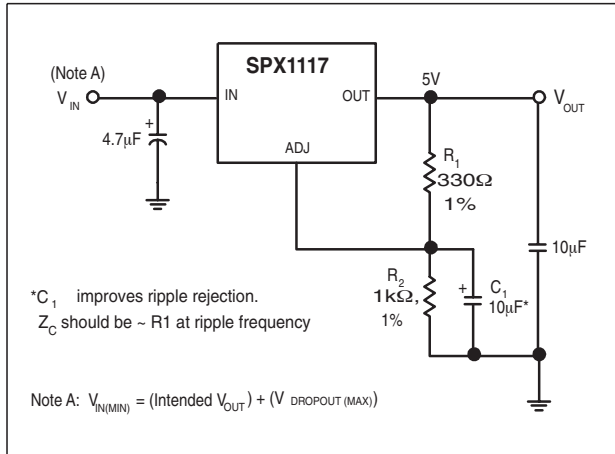

Figure 23. Improving Ripple Rejection

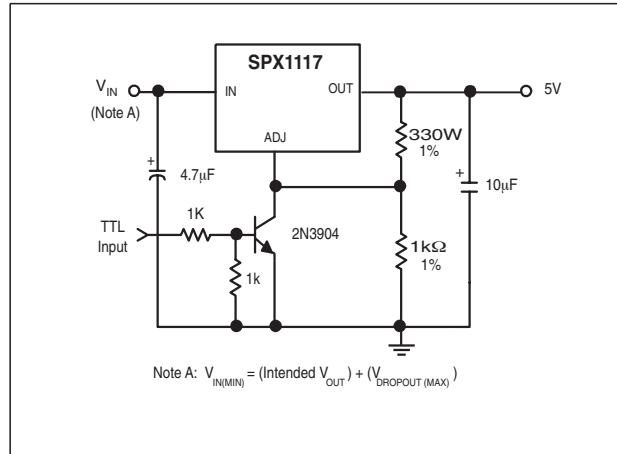

Figure 24. 5V Regulator with Shutdown

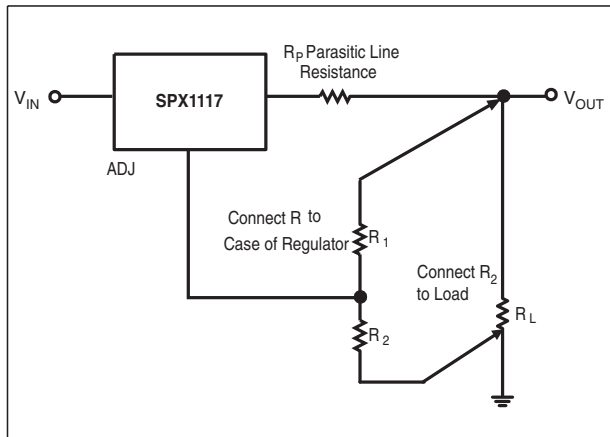
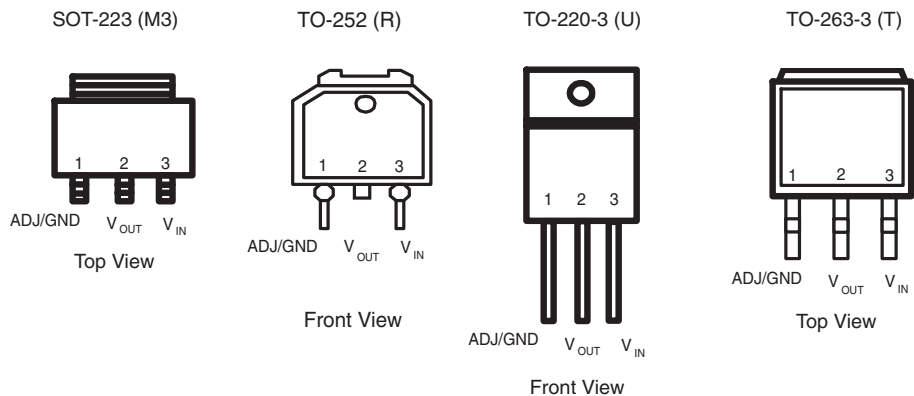
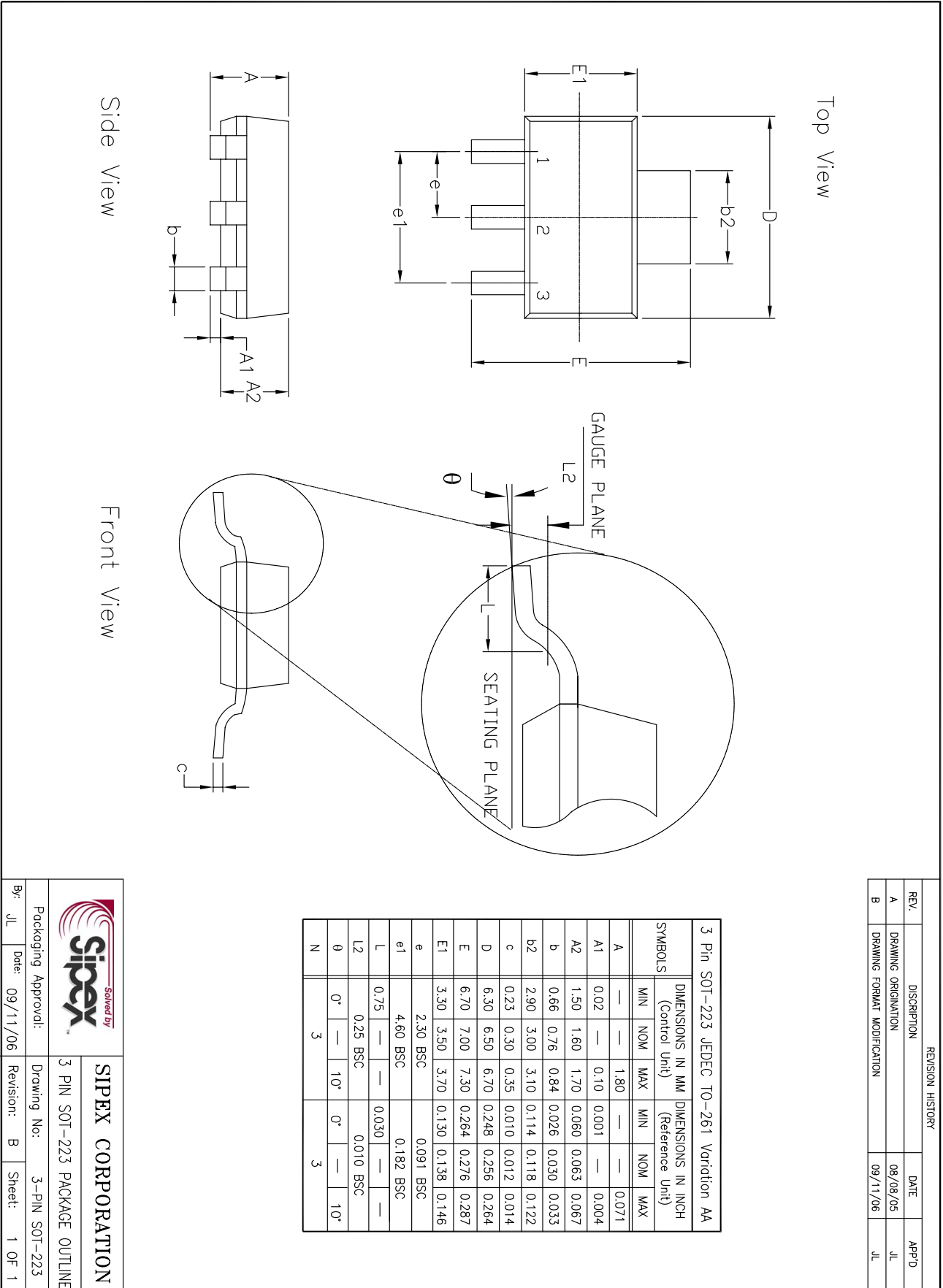

Figure 25. Recommended Connections for Best Results

PINOUTS



Note: For all Pinouts, TAB is connected to Pin2 VOUT.



REVISION HISTORY			
REV.	DISCREPTION	DATE	APP'D
A	DRAWING ORIGINATION	09/08/05	JL
B	DRAWING FORMAT MODIFICATION	09/11/06	JL

SYMBOLS	DIMENSIONS IN MM (Control Unit)			DIMENSIONS IN INCH (Reference Unit)		
	MIN	NOM	MAX	MIN	NOM	MAX
A	—	—	1.80	—	—	0.071
A1	0.02	—	0.10	0.001	—	0.004
A2	1.50	1.60	1.70	0.060	0.063	0.067
b	0.66	0.76	0.84	0.026	0.030	0.033
b2	2.90	3.00	3.10	0.114	0.118	0.122
c	0.23	0.30	0.35	0.010	0.012	0.014
D	6.30	6.50	6.70	0.248	0.256	0.264
E	6.70	7.00	7.30	0.264	0.276	0.287
E1	3.30	3.50	3.70	0.130	0.138	0.146
e	2.30 BSC			0.091 BSC		
e1	4.60 BSC			0.182 BSC		
L	0.75	—	—	0.030	—	—
L2	0.25 BSC		—	0.010 BSC		—
θ	0°	—	10°	0°	—	10°
N	3		—	3		—

SIPEX CORPORATION

3 PIN SOT-223 PACKAGE OUTLINE

By: JL Date: 09/11/06

Packaging Approval: Drawing No: 3-PIN SOT-223

Revision: B Sheet: 1 OF 1

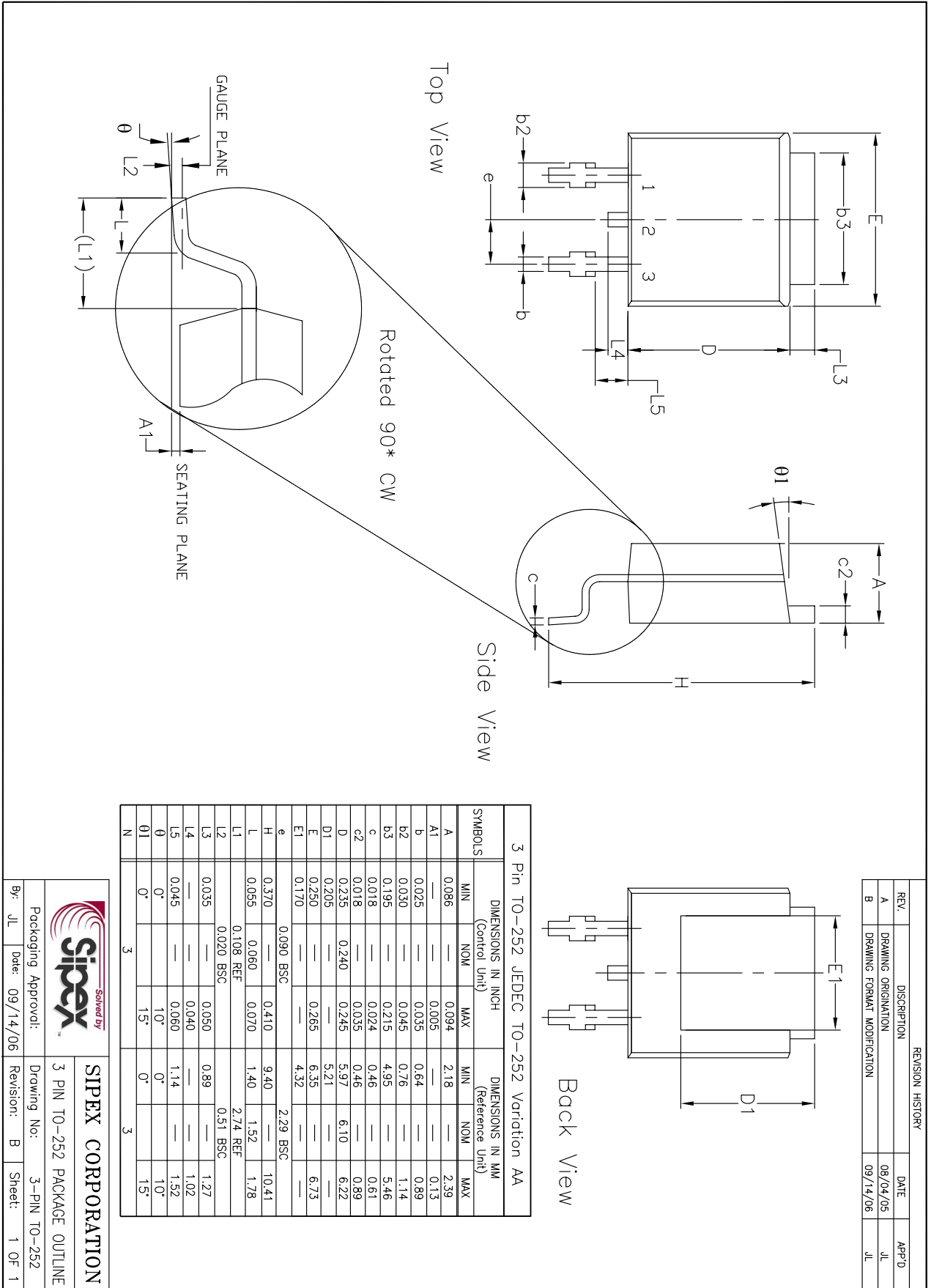

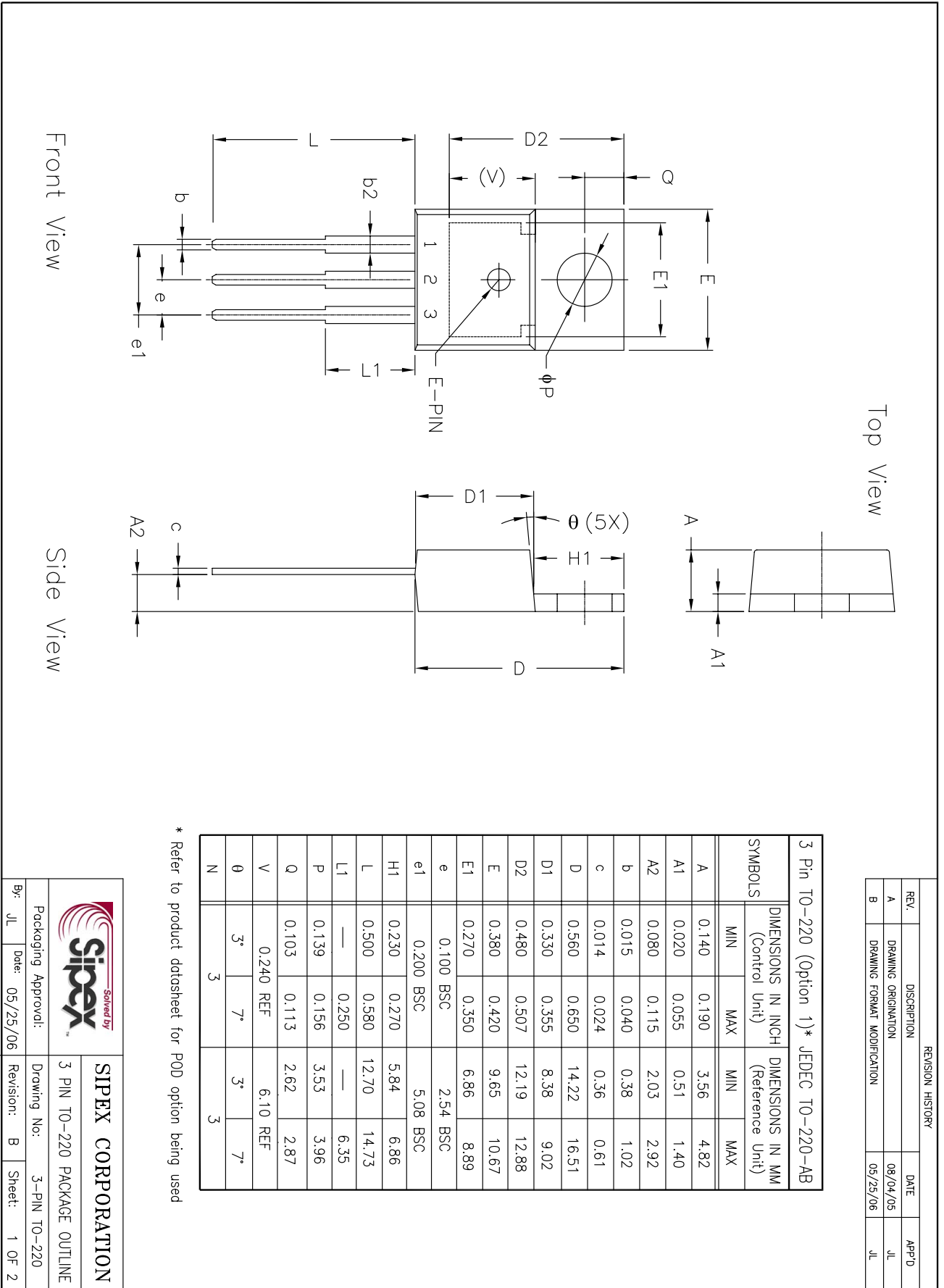

REVISION HISTORY			
REV.	DESCRIPTION	DATE	APP'D
A	DRAWING ORIGINATOR	08/04/05	JL
B	DRAWING FORMAT MODIFICATION	05/25/06	JL

SYMBOLS	DIMENSIONS IN INCH (Control Unit)		DIMENSIONS IN MM (Reference Unit)	
	MIN	MAX	MIN	MAX
A	0.140	0.190	3.56	4.82
A1	0.020	0.055	0.51	1.40
A2	0.080	0.115	2.03	2.92
b	0.015	0.040	0.38	1.02
c	0.014	0.024	0.36	0.61
D	0.560	0.650	14.22	16.51
D1	0.330	0.355	8.38	9.02
D2	0.480	0.507	12.19	12.88
E	0.380	0.420	9.65	10.67
E1	0.270	0.350	6.86	8.89
e	0.100 BSC		2.54 BSC	
e1	0.200 BSC		5.08 BSC	
H1	0.230	0.270	5.84	6.86
L	0.500	0.580	12.70	14.73
L1	—	0.250	—	6.35
P	0.139	0.156	3.53	3.96
Q	0.103	0.113	2.62	2.87
V	0.240 REF		6.10 REF	
θ	3°	7°	3°	7°
N	3	3	3	3

* Refer to product datasheet for POD option being used

		SIPLEX CORPORATION	
Packaging Approval:		Drawing No:	
By: JL	Date: 05/25/06	Revision: B	Sheet: 1 OF 2

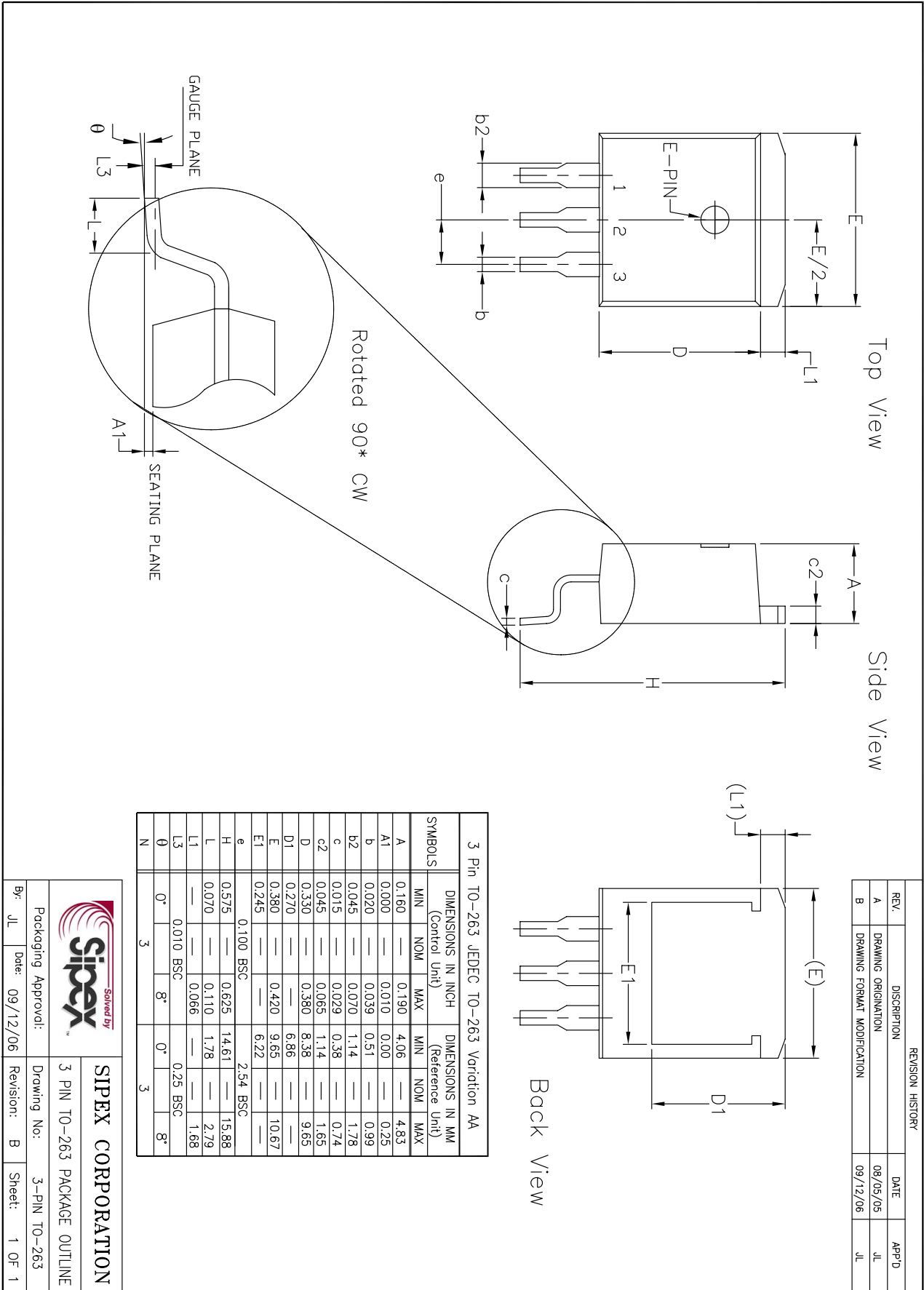

REVISION HISTORY			
REV.	DESCRIPTION	DATE	APP'D
A	DRAWING ORIGINATION	08/05/05	JL
B	DRAWING FORMAT MODIFICATION	09/12/06	JL

SYMBOLS	DIMENSIONS IN INCH (Control Unit)		DIMENSIONS IN MM (Reference Unit)	
	MIN	MAX	MIN	MAX
A	0.160	0.190	4.06	4.83
A1	0.000	0.010	0.00	0.25
b	0.020	0.039	0.51	0.99
b2	0.045	0.070	1.14	1.78
c	0.015	0.029	0.38	0.74
c2	0.045	0.065	1.14	1.65
D	0.330	0.380	8.38	9.65
D1	0.270	—	6.86	—
E	0.380	0.420	9.65	10.67
E1	0.245	—	6.22	—
e	0.100	—	2.54	—
H	0.575	0.625	14.61	15.88
L	0.070	0.110	1.78	2.79
L1	—	0.066	—	1.68
L3	0.010	BSC	0.25	BSC
θ	0°	8°	0°	8°
N	3	—	3	—

Sipex Solved by

SIPEX CORPORATION

Packaging Approval: 3 PIN TO-263 PACKAGE OUTLINE

By: JL Date: 09/12/06 Revision: B Sheet: 1 OF 1

Drawing No: 3-PIN TO-263

Ordering Information

Part Number	Status	RoHS	Package	Pack Type	Quantity
SPX1117HM3/TR	Active	No	SOT-223-3	Tape & Reel	2500
SPX1117HM3-L/TR	Active	Yes	SOT-223-3	Tape & Reel	2500
SPX1117HM3-L-1-8/TR	Active	Yes	SOT-223-3	Tape & Reel	2500
SPX1117M3	Active	No	SOT-223-3	TUBE	78
SPX1117M3/TR	Active	No	SOT-223-3	Tape & Reel	2500
SPX1117M3-1-5/TR	Active	No	SOT-223-3	Tape & Reel	2500
SPX1117M3-1-8/TR	Active	No	SOT-223-3	Tape & Reel	2500
SPX1117M3-2-5/TR	Active	No	SOT-223-3	Tape & Reel	2500
SPX1117M3-2-85	Active	No	SOT-223-3	TUBE	78
SPX1117M3-3-0/TR	Active	No	SOT-223-3	Tape & Reel	2500
SPX1117M3-3-3/TR	Active	No	SOT-223-3	Tape & Reel	2500
SPX1117M3-5-0/TR	Active	No	SOT-223-3	Tape & Reel	2500
SPX1117M3-L	Active	Yes	SOT-223-3	TUBE	78
SPX1117M3-L/TR	Active	Yes	SOT-223-3	Tape & Reel	2500
SPX1117M3-L-1-5	Active	Yes	SOT-223-3	TUBE	78
SPX1117M3-L-1-5/TR	Active	No	SOT-223-3	Tape & Reel	2500
SPX1117M3-L-1-8/TR	Active	Yes	SOT-223-3	Tape & Reel	2500
SPX1117M3-L-2-5/TR	Active	Yes	SOT-223-3	Tape & Reel	2500
SPX1117M3-L-2-85/TR	Active	Yes	SOT-223-3	Tape & Reel	2500
SPX1117M3-L-3-0	Active	Yes	SOT-223-3	TUBE	78
SPX1117M3-L-3-0/TR	Active	Yes	SOT-223-3	Tape & Reel	2500
SPX1117M3-L-3-3/TR	Active	Yes	SOT-223-3	Tape & Reel	2500
SPX1117M3-L-5-0/TR	Active	Yes	SOT-223-3	Tape & Reel	2500
SPX1117R	Active	No	TO-252-3	TUBE	77
SPX1117R/TR	Active	No	TO-252-3	Tape & Reel	2000
SPX1117R-1-5	Active	No	TO-252-3	TUBE	77
SPX1117R-1-5/TR	Active	No	TO-252-3	Tape & Reel	2000
SPX1117R-1-8	Active	No	TO-252-3	TUBE	77
SPX1117R-1-8/TR	Active	No	TO-252-3	Tape & Reel	2000
SPX1117R-2-5	Active	No	TO-252-3	TUBE	77
SPX1117R-2-5/TR	Active	No	TO-252-3	Tape & Reel	2000
SPX1117R-2-85	Active	No	TO-252-3	TUBE	77
SPX1117R-2-85/TR	Active	No	TO-252-3	Tape & Reel	2000
SPX1117R-3-0	Active	No	TO-252-3	TUBE	77
SPX1117R-3-0/TR	Active	No	TO-252-3	Tape & Reel	2000
SPX1117R-3-3	Active	No	TO-252-3	TUBE	77
SPX1117R-3-3/TR	Active	No	TO-252-3	Tape & Reel	2000
SPX1117R-L	Active	Yes	TO-252-3	TUBE	77
SPX1117R-L/TR	Active	Yes	TO-252-3	Tape & Reel	2000
SPX1117R-L-1-5	Active	Yes	TO-252-3	TUBE	77
SPX1117R-L-1-5/TR	Active	Yes	TO-252-3	Tape & Reel	2000
SPX1117R-L-1-8	Active	Yes	TO-252-3	TUBE	77
SPX1117R-L-1-8/TR	Active	Yes	TO-252-3	Tape & Reel	2000
SPX1117R-L-2-5	Active	Yes	TO-252-3	TUBE	77
SPX1117R-L-2-5/TR	Active	Yes	TO-252-3	Tape & Reel	2000
SPX1117R-L-2-85	Active	Yes	TO-252-3	TUBE	77
SPX1117R-L-2-85/TR	Active	Yes	TO-252-3	Tape & Reel	2000
SPX1117R-L-3-0	Active	Yes	TO-252-3	TUBE	77
SPX1117R-L-3-0/TR	Active	Yes	TO-252-3	Tape & Reel	2000
SPX1117R-L-3-3	Active	Yes	TO-252-3	TUBE	77
SPX1117R-L-3-3/TR	Active	Yes	TO-252-3	Tape & Reel	2000

Ordering Information

Part Number	Status	RoHS	Package	Pack Type	Quantity
SPX1117T	Active	No	TO-263-3	TUBE	50
SPX1117T/TR	Active	No	TO-263-3	Tape & Reel	500
SPX1117T-1-5	Active	No	TO-263-3	TUBE	50
SPX1117T-1-5/TR	Active	No	TO-263-3	Tape & Reel	500
SPX1117T-1-8	Active	No	TO-263-3	TUBE	50
SPX1117T-1-8/TR	Active	No	TO-263-3	Tape & Reel	500
SPX1117T-2-5	Active	No	TO-263-3	TUBE	50
SPX1117T-2-5/TR	Active	No	TO-263-3	Tape & Reel	500
SPX1117T-2-85	Active	No	TO-263-3	TUBE	50
SPX1117T-3-0	Active	No	TO-263-3	TUBE	50
SPX1117T-3-0/TR	Active	No	TO-263-3	Tape & Reel	500
SPX1117T-3-3	Active	No	TO-263-3	TUBE	50
SPX1117T-3-3/TR	Active	No	TO-263-3	Tape & Reel	500
SPX1117T-L	Active	Yes	TO-263-3	TUBE	50
SPX1117T-L/TR	Active	Yes	TO-263-3	Tape & Reel	500
SPX1117T-L-1-5	Active	Yes	TO-263-3	TUBE	50
SPX1117T-L-1-5/TR	Active	Yes	TO-263-3	Tape & Reel	500
SPX1117T-L-1-8	Active	Yes	TO-263-3	TUBE	50
SPX1117T-L-1-8/TR	Active	Yes	TO-263-3	Tape & Reel	500
SPX1117T-L-2-5	Active	Yes	TO-263-3	TUBE	50
SPX1117T-L-2-5/TR	Active	Yes	TO-263-3	Tape & Reel	500
SPX1117T-L-2-85	Active	Yes	TO-263-3	TUBE	50
SPX1117T-L-2-85/TR	Active	Yes	TO-263-3	Tape & Reel	50
SPX1117T-L-3-0	Active	Yes	TO-263-3	TUBE	50
SPX1117T-L-3-0/TR	Active	Yes	TO-263-3	Tape & Reel	500
SPX1117T-L-3-3	Active	Yes	TO-263-3	TUBE	50
SPX1117T-L-3-3/TR	Active	Yes	TO-263-3	Tape & Reel	500
SPX1117U	Active	No	TO-220-3	TUBE	50
SPX1117U-1-5	Active	No	TO-220-3	TUBE	50
SPX1117U-1-8	Active	No	TO-220-3	TUBE	50
SPX1117U-2-5	Active	No	TO-220-3	TUBE	50
SPX1117U-2-85	Active	No	TO-220-3	TUBE	50
SPX1117U-3-0	Active	No	TO-220-3	TUBE	50
SPX1117U-3-3	Active	No	TO-220-3	TUBE	50
SPX1117U-L	Active	Yes	TO-220-3	TUBE	50
SPX1117U-L-1-5	Active	Yes	TO-220-3	TUBE	50
SPX1117U-L-1-8	Active	Yes	TO-220-3	TUBE	50
SPX1117U-L-2-5	Active	Yes	TO-220-3	TUBE	50
SPX1117U-L-2-8-5	Active	Yes	TO-220-3	TUBE	50
SPX1117U-L-3-0	Active	Yes	TO-220-3	TUBE	50
SPX1117U-L-3-3	Active	Yes	TO-220-3	TUBE	50
SPX1117HM3	CF	No	SOT-223-3	TUBE	78

Ordering Information

Part Number	Status	RoHS	Package	Pack Type	Quantity
SPX1117HM3-1-5	CF	No	SOT-223-3	TUBE	78
SPX1117HM3-2-5	CF	No	SOT-223-3	TUBE	78
SPX1117HM3-3-3	CF	No	SOT-223-3	TUBE	78
SPX1117HM3-5-0	CF	No	SOT-223-3	TUBE	78
SPX1117HM3-L	CF	Yes	SOT-223-3	TUBE	78
SPX1117HM3-L-1-5	CF	Yes	SOT-223-3	TUBE	78
SPX1117HM3-L-1-5/TR	CF	Yes	SOT-223-3	Tape & Reel	2500
SPX1117HM3-L-1-8	CF	Yes	SOT-223-3	TUBE	78
SPX1117HM3-L-2-5	CF	Yes	SOT-223-3	TUBE	78
SPX1117HM3-L-2-5/TR	CF	Yes	SOT-223-3	Tape & Reel	2500
SPX1117HM3-L-2-85	CF	Yes	SOT-223-3	TUBE	78
SPX1117HM3-L-2-85/TR	CF	Yes	SOT-223-3	Tape & Reel	2500
SPX1117HM3-L-3-0	CF	Yes	SOT-223-3	TUBE	78
SPX1117HM3-L-3-0/TR	CF	Yes	SOT-223-3	Tape & Reel	2500
SPX1117HM3-L-3-3	CF	Yes	SOT-223-3	TUBE	78
SPX1117HM3-L-3-3/TR	CF	Yes	SOT-223-3	Tape & Reel	2500
SPX1117HM3-L-5-0	CF	Yes	SOT-223-3	TUBE	78
SPX1117HM3-L-5-0/TR	CF	Yes	SOT-223-3	Tape & Reel	2500
SPX1117M3-1-5	CF	No	SOT-223-3	TUBE	78
SPX1117M3-1-8	CF	No	SOT-223-3	TUBE	78
SPX1117M3-2-5	CF	No	SOT-223-3	TUBE	78
SPX1117M3-3-0	CF	No	SOT-223-3	TUBE	78
SPX1117M3-3-3	CF	No	SOT-223-3	TUBE	78
SPX1117M3-5-0	CF	No	SOT-223-3	TUBE	78
SPX1117M3-L-1-8	CF	Yes	SOT-223-3	TUBE	78
SPX1117M3-L-2-5	CF	Yes	SOT-223-3	TUBE	78
SPX1117M3-L-2-85	CF	Yes	SOT-223-3	TUBE	78
SPX1117M3-L-3-3	CF	Yes	SOT-223-3	TUBE	78
SPX1117M3-L-5-0	CF	Yes	SOT-223-3	TUBE	78
SPX1117HM3-1-5/TR	OBS	No	SOT-223-3	Tape & Reel	2500
SPX1117HM3-1-8	OBS	No	SOT-223-3	TUBE	78
SPX1117HM3-1-8/TR	OBS	No	SOT-223-3	Tape & Reel	2500
SPX1117HM3-2-5/TR	OBS	No	SOT-223-3	Tape & Reel	2500
SPX1117HM3-2-85	OBS	No	SOT-223-3	TUBE	78
SPX1117HM3-2-85/TR	OBS	No	SOT-223-3	Tape & Reel	2500
SPX1117HM3-3-0	OBS	No	SOT-223-3	TUBE	78
SPX1117HM3-3-0/TR	OBS	No	SOT-223-3	Tape & Reel	2500
SPX1117HM3-3-3/TR	OBS	No	SOT-223-3	Tape & Reel	2500
SPX1117HM3-5-0/TR	OBS	No	SOT-223-3	Tape & Reel	2500

For further assistance:

Email: Sipexsupport@sipex.com
 WWW Support page: <http://www.sipex.com/content.aspx?p=support>
 Sipex Application Notes: <http://www.sipex.com/applicationNotes.aspx>



Sipex Corporation
 Headquarters and
 Sales Office
 233 South Hillview Drive
 Milpitas, CA 95035
 tel: (408) 934-7500
 fax: (408) 935-7600

Sipex Corporation reserves the right to make changes to any products described herein. Sipex does not assume any liability arising out of the application or use of any product or circuit described herein; neither does it convey any license under its patent rights nor the rights of others.