

18-27 GHz 1W Power Amplifier

TGA1135B-SCC

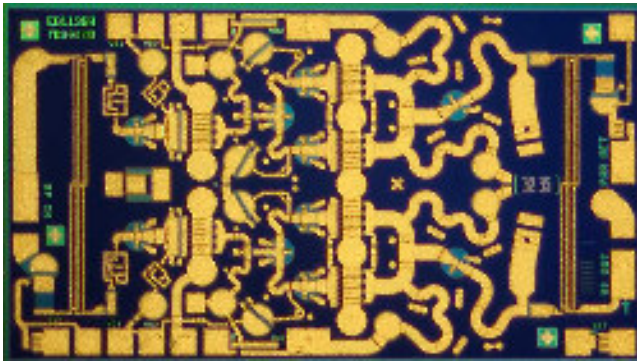

Chip Dimensions 2.641 mm x 1.480 mm x 0.1016mm

Product Description

The TriQuint TGA1135B-SCC is a balanced two-stage HPA MMIC design using TriQuint's proven 0.25 um Power pHEMT process. The TGA1135B is designed to support a variety of millimeter wave applications including point-to-point digital radio and LMDS/LMCS.

The balanced configuration two stage design consists of a pair of 600 um input devices driving a 4 x 600um output stage. Power combining is achieved with on-chip Lange couplers.

The TGA1135B-SCC provides 29 dBm nominal output power at 1dB compression across 18 - 27GHz. Typical small signal gain is 14 dB across the band. Input and output return loss is typically -15dB.

An on-chip power detector and reference diode may be used for power monitoring/control and bias control loops.

The TGA1135B-SCC requires minimum off-chip components. Each device is 100% DC and RF tested on-wafer to ensure performance compliance. The device is available in chip form.

Lead-Free and ROHS Compliant.

Key Features

- 0.25 um pHEMT Technology
- 14 dB Nominal Gain at 23GHz
- 29 dBm Nominal P1dB
- 37dBm OTOI typical
- Typical 15dB Input/Output RL
- Bias 6 - 7V @ 540 mA
- On-chip power detector diode

Primary Applications

- Point-to-Point Radio
- Point-to-Multipoint Communications
- K Band Sat-Com

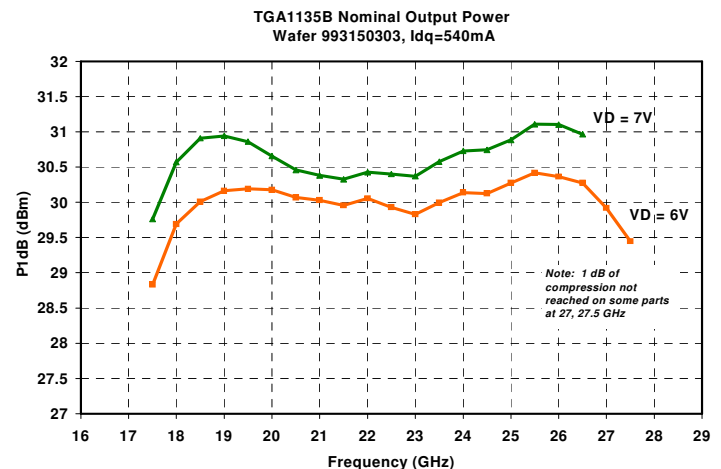
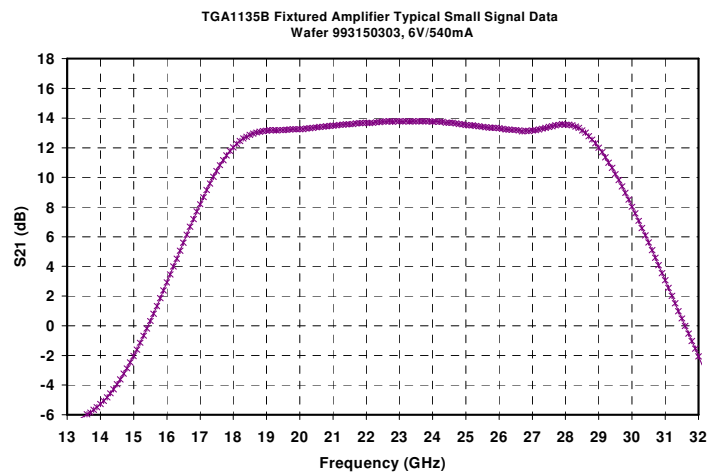

TABLE I
MAXIMUM RATINGS

SYMBOL	PARAMETER ^{4/}	VALUE	NOTES
V ⁺	POSITIVE SUPPLY VOLTAGE	13 V	
I ⁺	POSITIVE SUPPLY CURRENT	720 mA	<u>1/</u>
I ⁻	NEGATIVE SUPPLY CURRENT	28.2 mA	
P _{IN}	INPUT CONTINUOUS WAVE POWER	23 dBm	
P _D	POWER DISSIPATION	9.4 W	
T _{CH}	OPERATING CHANNEL TEMPERATURE	150 °C	<u>2/</u> <u>3/</u>
T _M	MOUNTING TEMPERATURE (30 SECONDS)	320 °C	
T _{STG}	STORAGE TEMPERATURE	-65 to 150 °C	

1/ Total current for all stages.

2/ These ratings apply to each individual FET.

3/ Junction operating temperature will directly affect the device median time to failure (T_M). For maximum life, it is recommended that junction temperatures be maintained at the lowest possible levels.

4/ These ratings represent the maximum operable values for the device.

TABLE II
DC SPECIFICATIONS (100%)
(T_A = 25 °C ± 5 °C)

NOTES	SYMBOL	TEST CONDITIONS <u>2/</u>	LIMITS		UNITS
			MIN	MAX	
	I _{DSS1}	STD	60	282	mA
	G _{M1}	STD	132	318	mS
<u>1/</u>	V _{P1}	STD	0.5	1.5	V
<u>1/</u>	V _{P2}	STD	0.5	1.5	V
<u>1/</u>	V _{P3-6}	STD	0.5	1.5	V
<u>1/</u>	V _{BVGD1}	STD	13	30	V
<u>1/</u>	V _{BVGS1}	STD	13	30	V

1/ V_P, V_{BVGD}, and V_{BVGS} are negative.

2/ The measurement conditions are subject to change at the manufacture's discretion (with appropriate notification to the buyer).

TABLE IV
RF SPECIFICATIONS
($T_A = 25^\circ\text{C} \pm 5^\circ\text{C}$)

NOTE	TEST	MEASUREMENT CONDITIONS 6V @ 540mA	VALUE			UNITS
			MIN	TYP	MAX	
	SMALL-SIGNAL GAIN MAGNITUDE	18 – 20 GHz 21 – 24 GHz 25 – 27 GHz	11.5 12 11.5	14 14 14		dB
	POWER OUTPUT AT 1 dB GAIN COMPRESSION	18 – 27 GHz	27	29		dBm
	INPUT RETURN LOSS MAGNITUDE	18 – 27 GHz	10	15		dB
	OUTPUT RETURN LOSS MAGNITUDE	18 – 27 GHz	10	15		dB
<u>1/</u>	OUTPUT THIRD ORDER INTERCEPT		34.5	37		dBm

1/ Output Third Order Intercept point minimum performance is measured at 18.0, 23.0, 26.0 GHz, fixed voltage, $V_d = 7.0\text{V}$, $V_g = V_{g1}$ value passed from S-parameter testing. Power in per tone = -2.0 dBm. Separation = 0.010 GHz.

TABLE V
RELIABILITY DATA

PARAMETER	BIAS CONDITIONS		P_{DISS} (W)	$R_{\theta JC}$ (C/W)	T_{CH} (°C)	T_M (HRS)
	V_D (V)	I_D (mA)				
$R_{\theta JC}$ Thermal resistance (channel to backside of carrier plate)	6	540	3.24	23.09	144.8	2.1E7

Note: Assumes eutectic attach using 1.5 mil 80/20 AuSn mounted to a 20 mil CuMo Carrier at 70°C baseplate temperature. Worst case condition with no RF applied, 100% of DC power is dissipated.

**Measured small signal data
6V, 540mA**

TGA1135B-SCC

S21

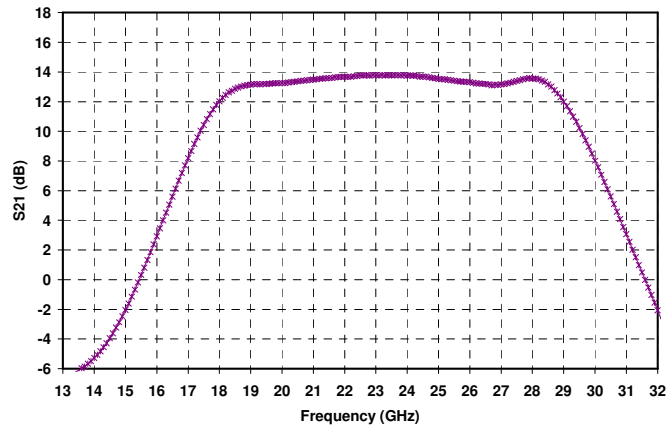

S11

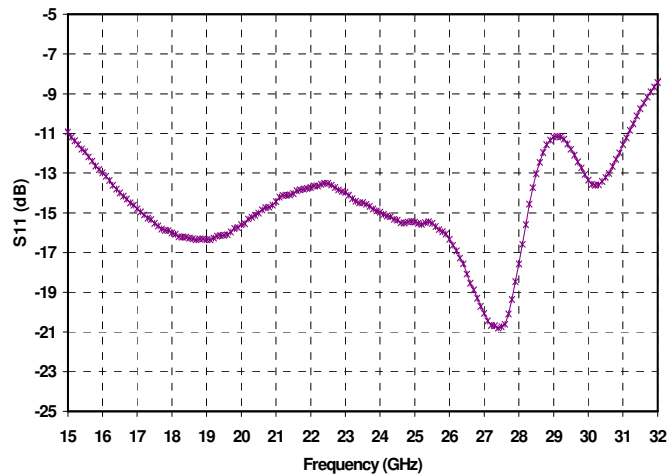

S22

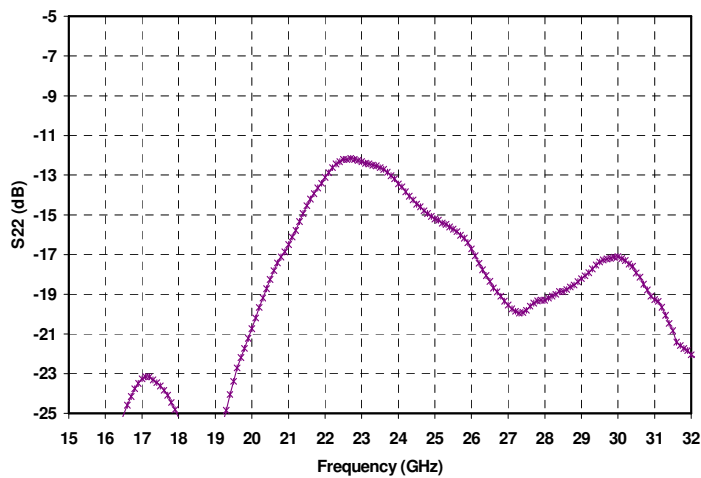

P1dB Measured Data for ~ 18K devices
 Vd = 6V, Id = 540 mA

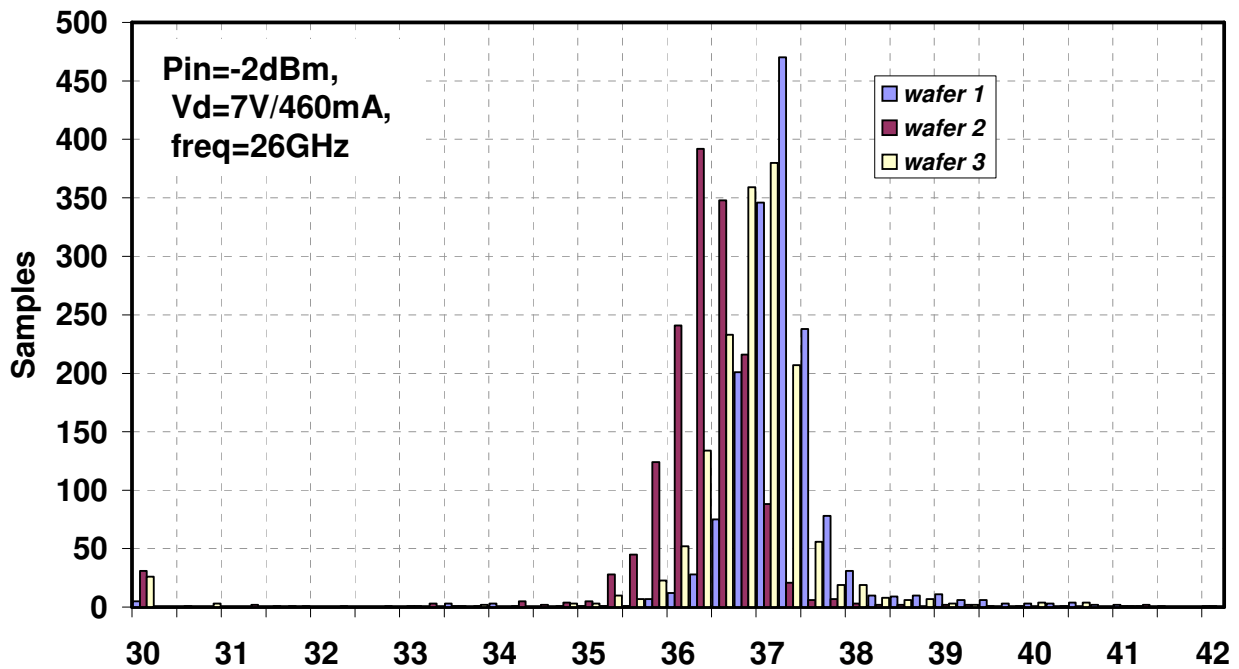
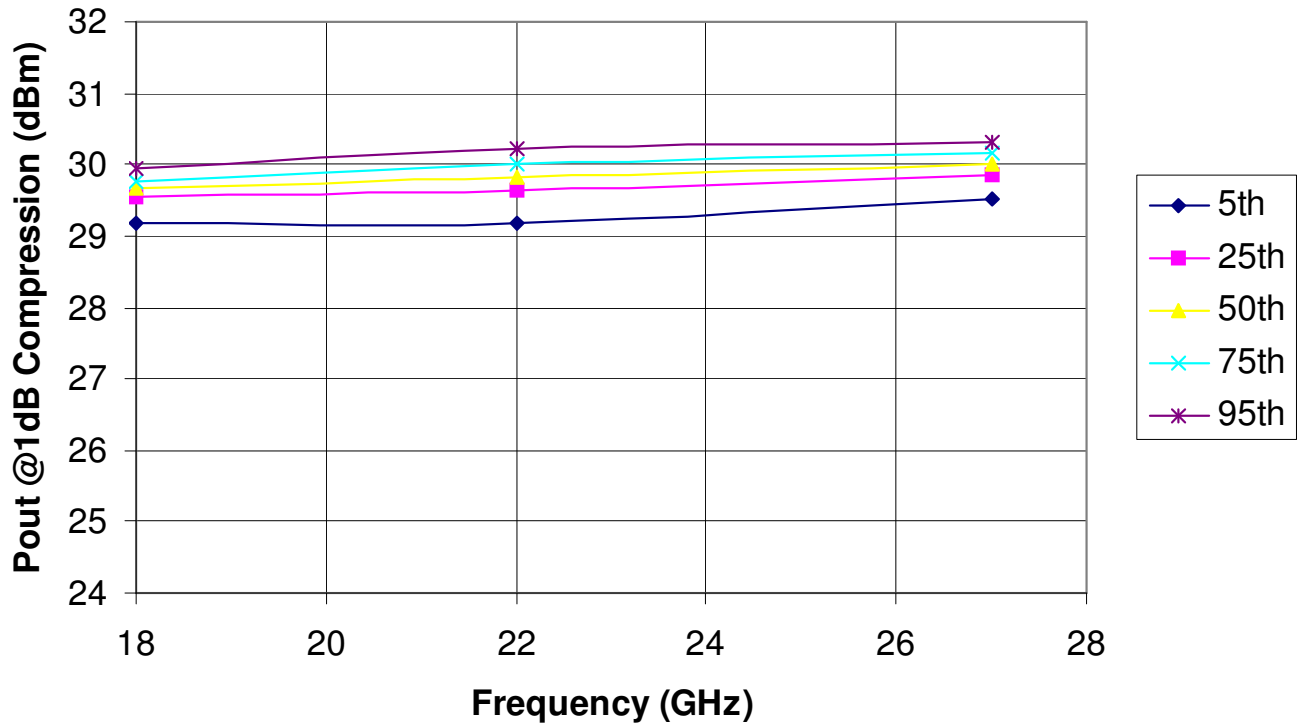

Typical Output TOI Measured Data

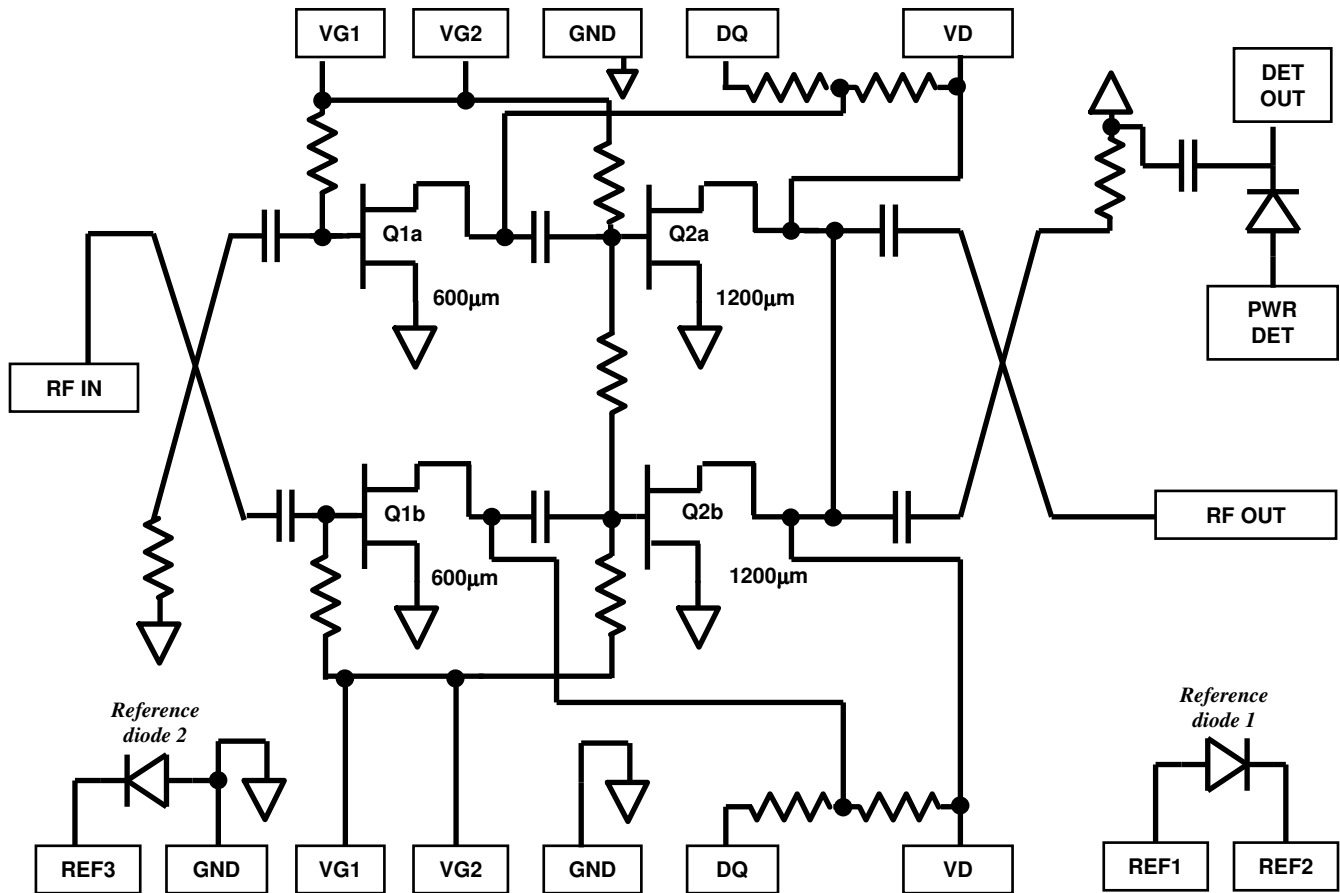

Note: no DC current allowed into the "DQ" pad

Note: If drain bias is from one side only, maximum Id is 440mA

DC Schematic

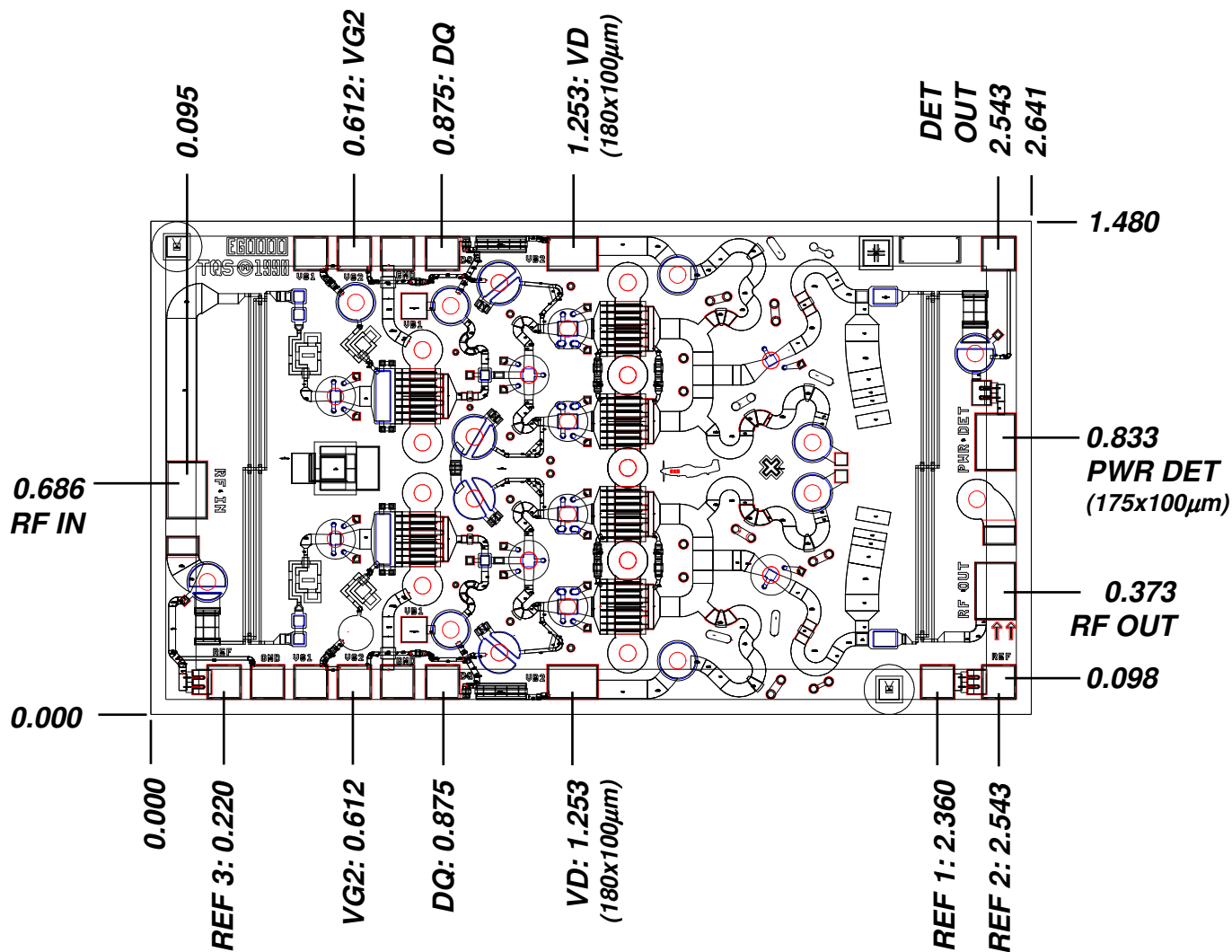

Dimensions in mm:

Chip Dimensions: 2.641 mm x 1.480 mm

Chip thickness: 0.1016mm

Chip edge to bond pads dimensions are shown to center of bond pad

RF I/O Pad: 200x100 mm

DC Pads: 105x105 mm

Die Area: 3.909 mm²

TGA1135B built-in power detector

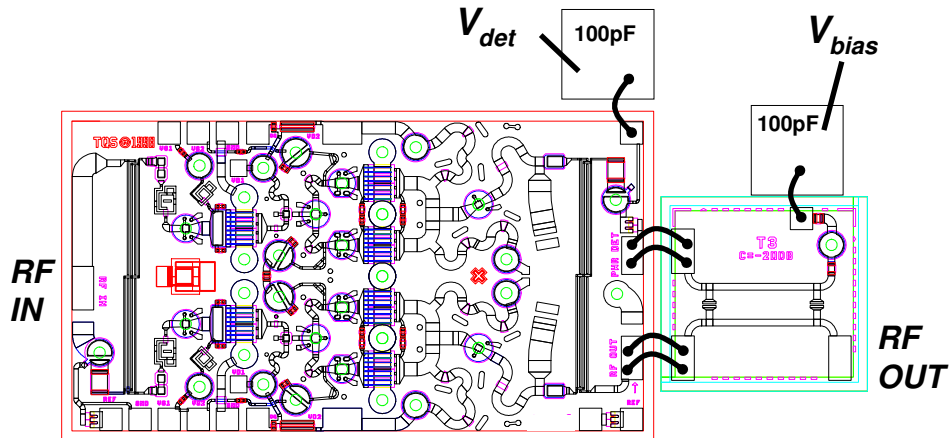

TGA1135B with external test coupler
(amplifier bias connections not shown)

On-chip diode functions as envelope detector
External coupler and DC bias required

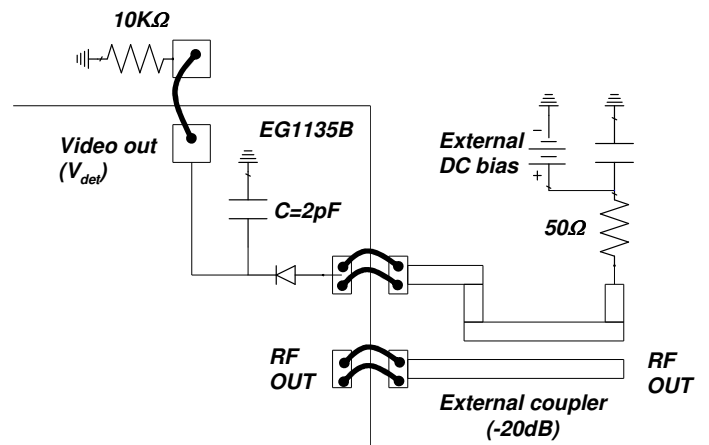
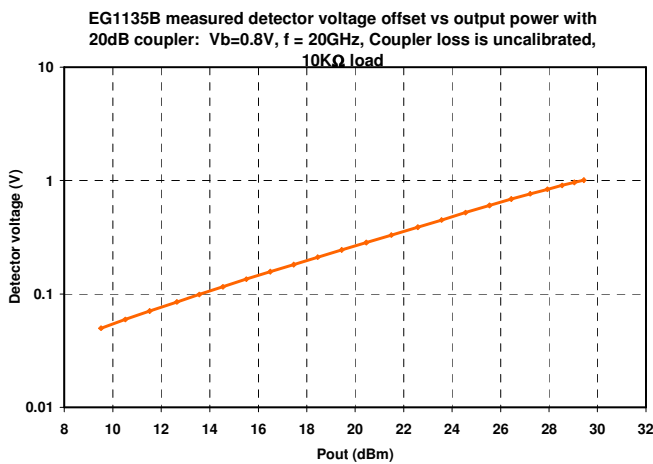

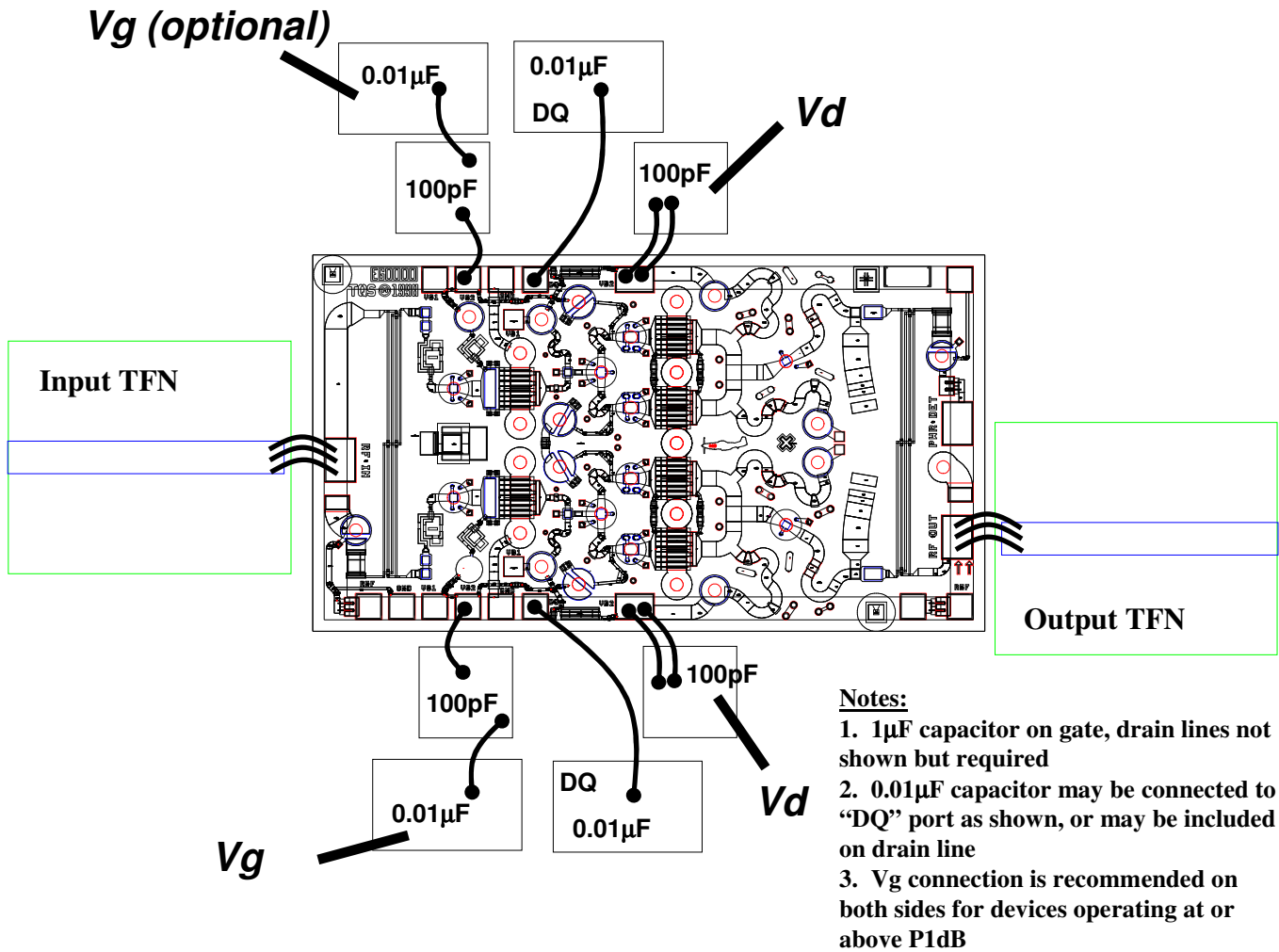

Chip Assembly and Bonding Diagram

GaAs MMIC devices are susceptible to damage from Electrostatic Discharge. Proper precautions should be observed during handling, assembly and test.

Assembly Process Notes

Reflow process assembly notes:

- AuSn (80/20) solder with limited exposure to temperatures at or above 300°C
- alloy station or conveyor furnace with reducing atmosphere
- no fluxes should be utilized
- coefficient of thermal expansion matching is critical for long-term reliability
- storage in dry nitrogen atmosphere

Component placement and adhesive attachment assembly notes:

- vacuum pencils and/or vacuum collets preferred method of pick up
- avoidance of air bridges during placement
- force impact critical during auto placement
- organic attachment can be used in low-power applications
- curing should be done in a convection oven; proper exhaust is a safety concern
- microwave or radiant curing should not be used because of differential heating
- coefficient of thermal expansion matching is critical

Interconnect process assembly notes:

- thermosonic ball bonding is the preferred interconnect technique
- force, time, and ultrasonics are critical parameters
- aluminum wire should not be used
- discrete FET devices with small pad sizes should be bonded with 0.0007-inch wire
- maximum stage temperature: 200°C

GaAs MMIC devices are susceptible to damage from Electrostatic Discharge. Proper precautions should be observed during handling, assembly and test.