

# Control Integrated Power System (CIPOS™)

IGCM20F60GA

<http://www.lspst.com>



For Power Management  
Application

**LS** Power Semitech  
A joint venture with infineon

---

<b>Revision History:</b>	2010-08	Ver.1.1
Previous Version:	Datasheet Ver. 1.0	
Page	Subjects (major changes since last revision)	
11	t <sub>FLTCLR</sub>	

---

**Authors: Junho Song, Junbae Lee and Daewoong Chung**

**Edition 2010-07**

**Published by**  
**LS Power Semitech Co., Ltd.**  
**Seoul, Korea**

**© LS Power Semitech Co., Ltd.**  
**All Rights Reserved.**

**Attention please!**

The information given in this data sheet shall in no event be regarded as a guarantee of conditions or characteristics. With respect to any examples or hints given herein, any typical values stated herein and/or any information regarding the application of the device, LS Power Semitech Co., Ltd. hereby disclaims any and all warranties and liabilities of any kind, including without limitation warranties of non-infringement of intellectual property rights of any third party.

**Information**

For further information on technology, delivery terms and conditions and prices please contact your nearest LS Power Semitech Co., Ltd. office or representatives (<http://www.lspst.com>).

**Warnings**

Due to technical requirements components may contain dangerous substances. For information on the types in question please contact your nearest LS Power Semitech Co., Ltd. office or representatives.

LS Power Semitech Co., Ltd. components may only be used in life-support devices or systems with the express written approval LS Power Semitech Co., Ltd., if a failure of such components can reasonably be expected to cause the failure of that life-support device or system, or to affect the safety or effectiveness of that device or system. Life support devices or systems are intended to be implanted in the human body, or to support and/or maintain and sustain and/or protect human life. If they fail, it is reasonable to assume that the health of the user or other persons may be endangered.

## Table of Contents

<b>CIPOS™ Control Integrated Power System.....</b>	<b>4</b>
<b>Features.....</b>	<b>4</b>
<b>Target Applications .....</b>	<b>4</b>
<b>Description .....</b>	<b>4</b>
<b>System Configuration .....</b>	<b>4</b>
<b>Pin Configuration.....</b>	<b>5</b>
<b>Internal Electrical Schematic.....</b>	<b>5</b>
<b>Pin Assignment.....</b>	<b>6</b>
<b>Pin Description .....</b>	<b>6</b>
HIN(U,V,W) and LIN(U,V,W) (Low side and high side control pins, Pin 7 - 12).....	6
VFO (Fault-output and NTC, Pin 14).....	7
ITRIP (Over current detection function, Pin 15).....	7
VDD, VSS (Low side control supply and reference, Pin 13, 16).....	7
VB(U,V,W) and VS(U,V,W) (High side supplies, Pin 1, 2, 3, 4, 5, 6).....	7
NU, NV, NW (Low side emitter, Pin 17, 18, 19).....	7
P (Positive bus input voltage, Pin 23).....	7
<b>Absolute Maximum Ratings.....</b>	<b>8</b>
<b>Module Section .....</b>	<b>8</b>
<b>RC-IGBT Section.....</b>	<b>8</b>
<b>Control Section .....</b>	<b>8</b>
<b>Recommended Operation Conditions .....</b>	<b>9</b>
<b>Static Parameters.....</b>	<b>10</b>
<b>Dynamic Parameters .....</b>	<b>11</b>
<b>Bootstrap Parameters .....</b>	<b>11</b>
<b>Thermistor .....</b>	<b>12</b>
<b>Mechanical Characteristics and Ratings.....</b>	<b>12</b>
<b>Circuit of a Typical Application .....</b>	<b>13</b>
<b>Switching Times Definition.....</b>	<b>13</b>
<b>Package Outline.....</b>	<b>14</b>

# CIPOS™

## Control Integrated **PO**wer **S**ystem

*Dual In-Line Intelligent Power Module*

*3Φ-bridge 600V / 20A*



### Features

Fully isolated Dual In-Line molded module

- Infineon reverse conducting IGBTs with monolithic body diode
- Rugged SOI gate driver technology with stability against transient and negative voltage
- Allowable negative VS potential up to -11V for signal transmission at VBS=15V
- Integrated bootstrap functionality
- Over current shutdown
- Temperature monitor
- Under-voltage lockout at all channels
- Low side emitter pins accessible for all phase current monitoring (open emitter)
- Cross-conduction prevention
- All of 6 switches turn off during protection
- Lead-free terminal plating; RoHS compliant

### Target Applications

- Dish washers
- Refrigerators
- Washing machines
- Air-conditioners
- Fans
- Low power motor drives

### Description

The CIPOS™ module family offers the chance for integrating various power and control components to increase reliability, optimize PCB size and system costs.

It is designed to control three phase AC motors and permanent magnet motors in variable speed drives for applications like air conditioning, refrigerator and washing machine. The package concept is specially adapted to power applications, which need good thermal conduction and electrical isolation, but also EMI-save control and overload protection. The features of Infineon reverse conducting IGBT are combined with an optimized SOI gate driver for excellent electrical performance.

### System Configuration

- 3 half bridges with reverse conducting IGBT
- 3Φ SOI gate driver
- Thermistor
- Pin-to-heatsink creepage distance typ. 1.6mm

## Pin Configuration

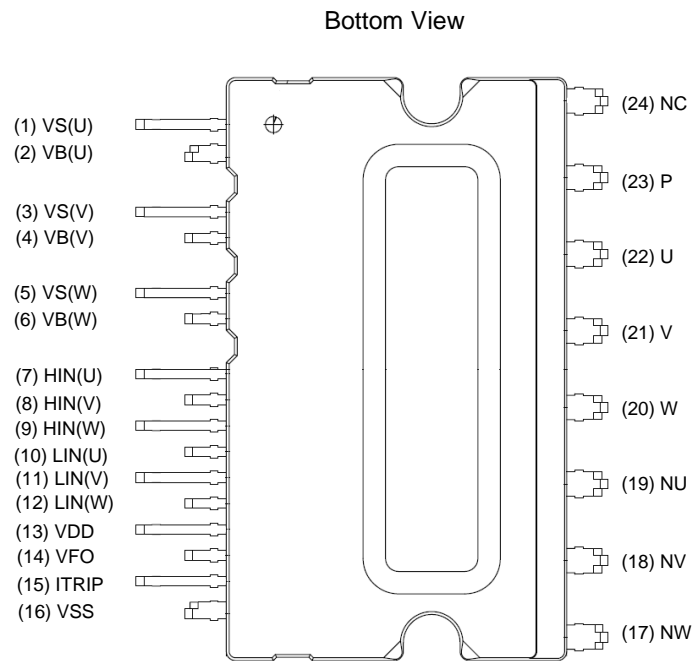

Figure 1: Pin configuration

## Internal Electrical Schematic

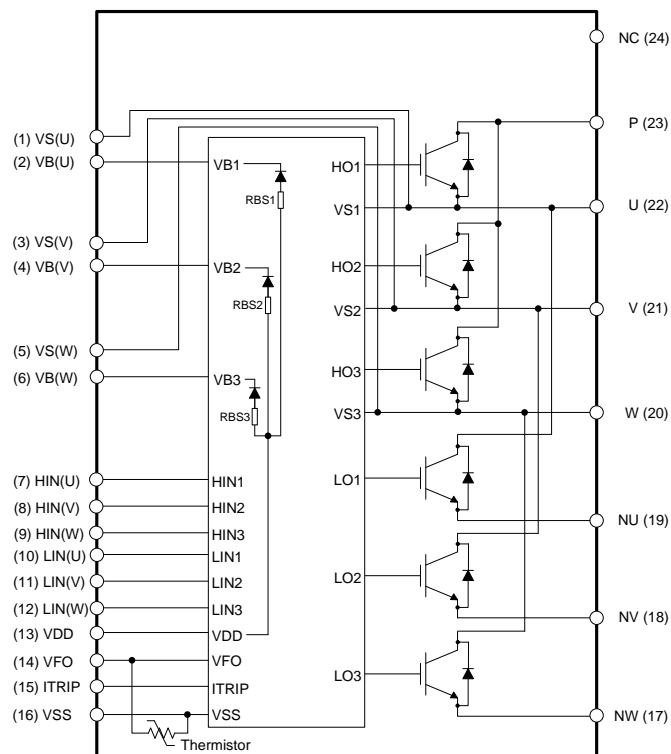

Figure 2: Internal schematic

**Pin Assignment**

Pin Number	Pin Name	Pin Description
1	VS(U)	U-phase high side floating IC supply offset voltage
2	VB(U)	U-phase high side floating IC supply voltage
3	VS(V)	V-phase high side floating IC supply offset voltage
4	VB(V)	V-phase high side floating IC supply voltage
5	VS(W)	W-phase high side floating IC supply offset voltage
6	VB(W)	W-phase high side floating IC supply voltage
7	HIN(U)	U-phase high side gate driver input
8	HIN(V)	V-phase high side gate driver input
9	HIN(W)	W-phase high side gate driver input
10	LIN(U)	U-phase low side gate driver input
11	LIN(V)	V-phase low side gate driver input
12	LIN(W)	W-phase low side gate driver input
13	VDD	Low side control supply
14	VFO	Fault output / Temperature monitor
15	ITRIP	Over current shutdown input
16	VSS	Low side control negative supply
17	NW	W-phase low side emitter
18	NV	V-phase low side emitter
19	NU	U-phase low side emitter
20	W	Motor W-phase output
21	V	Motor V-phase output
22	U	Motor U-phase output
23	P	Positive bus input voltage
24	NC	No Connection

**Pin Description**

**HIN(U,V,W) and LIN(U,V,W) (Low side and high side control pins, Pin 7 - 12)**

These pins are positive logic and they are responsible for the control of the integrated IGBT. The Schmitt-trigger input threshold of them are such to guarantee LSTTL and CMOS compatibility down to 3.3V controller outputs. Pull-down resistor of about 5kΩ is internally provided to pre-bias inputs during supply start-up and a zener clamp is provided for pin protection purposes. Input schmitt-trigger and noise filter provide beneficial noise rejection to short input pulses.

The noise filter suppresses control pulses which are below the filter time  $t_{FILIN}$ . The filter acts according to Figure 4.

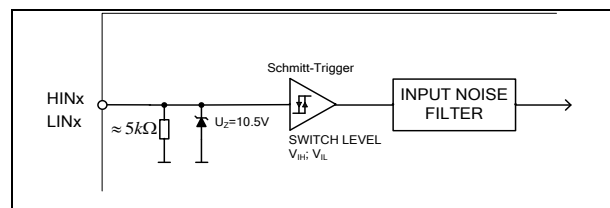

**Figure 3: Input pin structure**

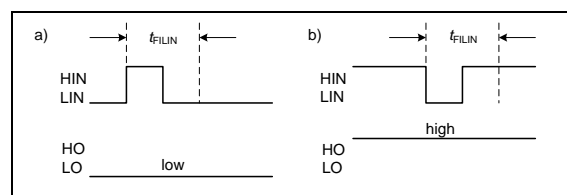

**Figure 4: Input filter timing diagram**

It is recommended for proper work of CIPOS™ not to provide input pulse-width lower than 1 $\mu$ s.

The integrated gate drive provides additionally a shoot through prevention capability which avoids the simultaneous on-state of two gate drivers of the same leg (i.e. HO1 and LO1, HO2 and LO2, HO3 and LO3). When two inputs of a same leg are activated, only former activated one is activated so that the leg is kept steadily in a safe state.

A minimum deadtime insertion of typ 380ns is also provided by driver IC, in order to reduce cross-conduction of the external power switches.

#### **VFO (Fault-output and NTC, Pin 14)**

The VFO pin indicates a module failure in case of under voltage at pin VDD or in case of triggered over current detection at ITRIP. A pull-up resistor is externally required to bias the NTC.

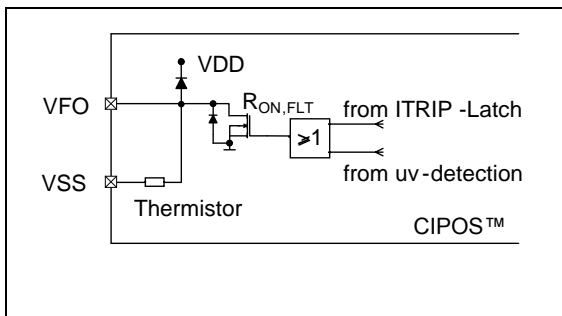

**Figure 5: Internal circuit at pin VFO**

The same pin provides direct access to the NTC, which is referenced to VSS. An external pull-up resistor connected to +5V ensures, that the resulting voltage can be directly connected to the microcontroller.

#### **ITRIP (Over current detection function, Pin 15)**

CIPOS™ provides an over current detection function by connecting the ITRIP input with the motor current feedback. The ITRIP comparator threshold (typ 0.47V) is referenced to VSS ground. A input noise filter (typ:  $t_{TRIPMIN} = 530ns$ ) prevents the driver to detect false over-current events.

Over current detection generates a shut down of all outputs of the gate driver after the shutdown propagation delay of typically 1000ns.

The fault-clear time is set to typical 65 $\mu$ s.

#### **VDD, VSS (Low side control supply and reference, Pin 13, 16)**

VDD is the low side supply and it provides power both to input logic and to low side output power stage. Input logic is referenced to VSS ground.

The under-voltage circuit enables the device to operate at power on when a supply voltage of at least a typical voltage of  $V_{DDUV+} = 12.1V$  is present.

The IC shuts down all the gate drivers power outputs, when the VDD supply voltage is below  $V_{DDUV-} = 10.4V$ . This prevents the external power switches from critically low gate voltage levels during on-state and therefore from excessive power dissipation.

#### **VB(U,V,W) and VS(U,V,W) (High side supplies, Pin 1, 2, 3, 4, 5, 6)**

VB to VS is the high side supply voltage. The high side circuit can float with respect to VSS following the external high side power device emitter voltage.

Due to the low power consumption, the floating driver stage is supplied by integrated bootstrap circuit.

The under-voltage detection operates with a rising supply threshold of typical  $V_{BSUV+} = 12.1V$  and a falling threshold of  $V_{DDUV-} = 10.4V$ .

VS(U,V,W) provide a high robustness against negative voltage in respect of VSS of -50V transiently. This ensures very stable designs even under rough conditions.

#### **NU, NV, NW (Low side emitter, Pin 17, 18, 19)**

The low side emitters are available for current measurements of each phase leg. It is recommended to keep the connection to pin VSS as short as possible in order to avoid unnecessary inductive voltage drops.

#### **P (Positive bus input voltage, Pin 23)**

The high side IGBT are connected to the bus voltage. It is recommended that the bus voltage does not exceed 400 V.

### Absolute Maximum Ratings

( $V_{DD} = 15V$  and  $T_C = 25^\circ C$ , if not stated otherwise)

#### Module Section

Description	Condition	Symbol	Value		Unit
			min	max	
Storage temperature range		$T_{stg}$	-40	125	$^\circ C$
Insulation test voltage	RMS, $f=60Hz$ , $t=1min$	$V_{ISOL}$	2000	-	V
Operating case temperature range	Refer to Figure 6	$T_C$	-40	100	$^\circ C$

#### RC-IGBT Section

Description	Condition	Symbol	Value		Unit
			min	max	
Max. blocking voltage	$I_C=250\mu A$	$V_{CES}$	600	-	V
Output current	$T_C = 25^\circ C, T_J < 150^\circ C$ $T_C = 80^\circ C, T_J < 150^\circ C$	$I_C$	-20 -15	20 15	A
Maximum peak output current	less than 1ms	$I_C$	-45	45	A
Short circuit withstand time	$V_{DC} \leq 400V$	$t_{SC}$	-	5	$\mu s$
Power dissipation per IGBT		$P_{tot}$	-	33	W
Operating junction temperature range		$T_J$	-40	150	$^\circ C$
Single IGBT thermal resistance, junction-case		$R_{thJC}$	-	3.84	K/W

#### Control Section

Description	Condition	Symbol	Value		Unit
			min	max	
Module supply voltage		$V_{DD}$	-1	20	V
High side floating supply voltage (VB vs. VS)		$V_{BS}$	-1	20	V
Input voltage	LIN, HIN, ITRIP	$V_{IN}$ $V_{ITRIP}$	-1 -1	10 10	V
Switching frequency		$f_{PWM}$	-	20	kHz



### Recommended Operation Conditions

All voltages are absolute voltages referenced to  $V_{SS}$  -potential unless otherwise specified.

Description	Symbol	Value			Unit
		min	typ	max	
DC link supply voltage	$V_{DC}$	0	-	400	V
High side floating supply voltage ( $V_B$ vs. $V_S$ )	$V_{BS}$	13.5	-	18.5	V
Low side supply voltage	$V_{DD}$	14.0	16	18.5	V
Control supply variation	$\Delta V_{BS}$ ,	-1	-	1	V/ $\mu$ s
	$\Delta V_{DD}$	-1	-	1	
Logic input voltages LIN,HIN,ITRIP	$V_{IN}$	0	-	5	V
	$V_{ITRIP}$	0	-	5	
Between $V_{SS}$ - N (including surge)	$V_{SS}$	-5	-	5	V

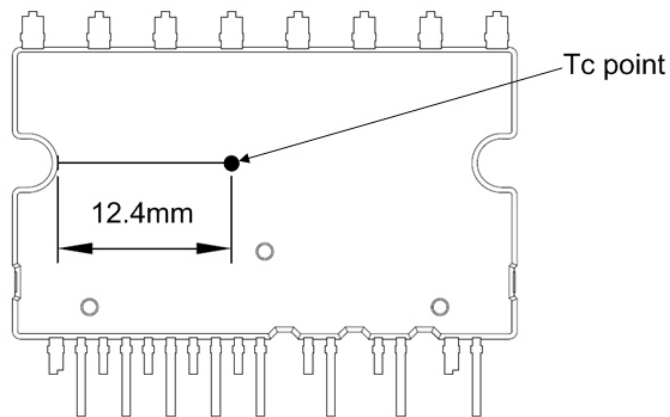

**Figure 6:  $T_C$  measurement point**

**Static Parameters**

( $V_{DD} = 15V$  and  $T_C = 25^\circ C$ , if not stated otherwise)

Description	Condition	Symbol	Value			Unit
			min	typ	max	
Collector-Emitter saturation voltage	$I_{out} = 15A$ $T_J = 25^\circ C$ $150^\circ C$	$V_{CE(sat)}$	- -	1.6 1.8	2.0 -	V
Emitter-Collector forward voltage	$I_{out} = -15A$ $T_J = 25^\circ C$ $150^\circ C$	$V_F$	- -	1.75 1.8	2.2	V
Collector-Emitter leakage current	$V_{CE} = 600V$	$I_{CES}$	-	-	1	mA
Logic "1" input voltage (LIN,HIN)		$V_{IH}$	-	2.1	2.5	V
Logic "0" input voltage (LIN,HIN)		$V_{IL}$	0.7	0.9	-	V
ITRIP positive going threshold		$V_{IT,TH+}$	400	470	540	mV
ITRIP input hysteresis		$V_{IT,HYS}$	40	70	-	mV
$V_{DD}$ and $V_{BS}$ supply under voltage positive going threshold		$V_{DDUV+}$ $V_{BSUV+}$	10.8	12.1	13.0	V
$V_{DD}$ and $V_{BS}$ supply under voltage negative going threshold		$V_{DDUV-}$ $V_{BSUV-}$	9.5	10.4	11.2	V
$V_{DD}$ and $V_{BS}$ supply under voltage lockout hysteresis		$V_{DDUVH}$ $V_{BSUVH}$	1.0	1.7	-	V
Input clamp voltage (HIN, LIN, ITRIP)	$I_{in} = 4mA$	$V_{INCLAMP}$	9.0	10.1	12.5	V
Quiescent $V_{Bx}$ supply current ( $V_{Bx}$ only)	$H_{IN} = 0V$	$I_{QBS}$	-	300	500	$\mu A$
Quiescent $V_{DD}$ supply current ( $V_{DD}$ only)	$L_{IN} = 0V, H_{INX} = 5V$	$I_{QDD}$	-	370	900	$\mu A$
Input bias current	$V_{IN} = 5V$	$I_{IN+}$	-	1	1.5	mA
Input bias current	$V_{IN} = 0V$	$I_{IN-}$	-	2	-	$\mu A$
ITRIP input bias current	$V_{ITRIP} = 5V$	$I_{ITRIP+}$	-	65	150	$\mu A$
VFO input bias current	$VFO = 5V, V_{ITRIP} = 0V$	$I_{FO}$	-	60	-	$\mu A$
VFO output voltage	$I_{FO} = 10mA, V_{ITRIP} = 1V$	$V_{FO}$	-	0.5	-	V

## Dynamic Parameters

( $V_{DD} = 15V$  and  $T_C = 25^\circ C$ , if not stated otherwise)

Description	Condition	Symbol	Value			Unit
			min	typ	max	
Turn-on propagation delay	$V_{LIN,HIN} = 5V$ ; $I_{out} = 15A$ , $V_{DC} = 300V$	$t_{d(on)}$	-	650	-	ns
Turn-on rise time	$V_{LIN,HIN} = 5V$ ; $I_{out} = 15A$ , $V_{DC} = 300V$	$t_r$	-	45	-	ns
Turn-off propagation delay	$V_{LIN,HIN} = 0V$ ; $I_{out} = 15A$ , $V_{DC} = 300V$	$t_{d(off)}$	-	970	-	ns
Turn-off fall time	$V_{LIN,HIN} = 0V$ ; $I_{out} = 15A$ , $V_{DC} = 300V$	$t_f$	-	130	-	ns
Short circuit propagation delay	From $V_{IT,TH+}$ to 10% $I_{SC}$	$t_{SCP}$	-	1250	-	ns
Input filter time ITRIP	$V_{ITRIP} = 1V$	$t_{ITRIPmin}$	-	530	-	ns
Input filter time at LIN, HIN for turn on and off	$V_{LIN,HIN} = 0V$ & $5V$	$t_{FILIN}$	-	290	-	ns
Fault clear time after ITRIP-fault	$V_{ITRIP} = 1V$	$t_{FLTCLR}$	40	65	130	$\mu s$
Deadtime between low side and high side		$DT_{PWM}$	1.5	-	-	$\mu s$
Deadtime of gate drive circuit		$DT_{IC}$		380		ns
IGBT turn-on energy (includes reverse recovery of diode)	$V_{DC} = 300V$ , $I_C = 15A$ , $T_J = 25^\circ C$ $150^\circ C$	$E_{on}$	-	400	-	$\mu J$
IGBT turn-off energy	$V_{DC} = 300V$ , $I_C = 15A$ , $T_J = 25^\circ C$ $150^\circ C$	$E_{off}$	-	430	-	$\mu J$
Diode recovery energy	$V_{DC} = 300V$ , $I_C = 15A$ , $T_J = 25^\circ C$ $150^\circ C$	$E_{rec}$	-	95	-	$\mu J$

## Bootstrap Parameters

( $T_C = 25^\circ C$ , if not stated otherwise)

Description	Condition	Symbol	Value			Unit
			min	typ	max	
Repetitive peak reverse voltage		$V_{RRM}$	600			V
Bootstrap resistance of U-phase <sup>1</sup>	$VS2$ or $VS3=300V$ , $T_J=25^\circ C$ $VS2$ and $VS3=0V$ , $T_J=25^\circ C$ $VS2$ or $VS3=300V$ , $T_J=125^\circ C$ $VS2$ and $VS3=0V$ , $T_J=125^\circ C$	$R_{BS1}$		35 40 50 65		$\Omega$
Reverse recovery time	$I_F=0.6A$ , $di/dt=80A/\mu s$	$t_{rr,BS}$		50		ns
Forward voltage drop	$I_F=20mA$ , $VS2$ and $VS3=0V$	$V_{F,BS}$		2.6		V

<sup>1</sup>  $R_{BS2}$  and  $R_{BS3}$  have same values to  $R_{BS1}$ .

**Thermistor**

Description	Condition	Symbol	Value			Unit
			min	typ	max	
Resistor	$T_{NTC} = 25^{\circ}C$	$R_{NTC}$	-	85	-	k $\Omega$
B-constant of NTC (Negative temperature coefficient)		B(25/100)	-	4092	-	K

**Mechanical Characteristics and Ratings**

Description	Condition	Value			Unit
		min	typ	max	
Mounting torque	M3 screw and washer	0.59	0.69	0.78	Nm
Flatness	Refer to Figure 7	-50	-	100	$\mu m$
Weight		-	6.15	-	g

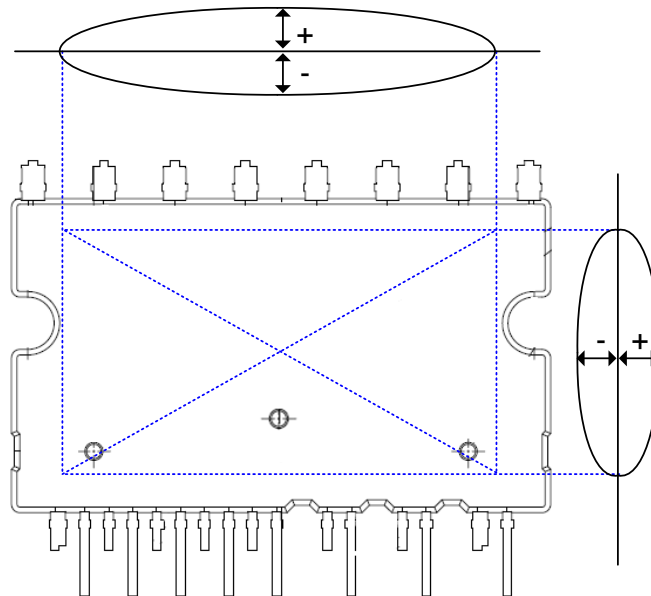

**Figure 7: Flatness measurement position**



**CIPOS™ IGCM20F60GA**

**Package Outline**

