

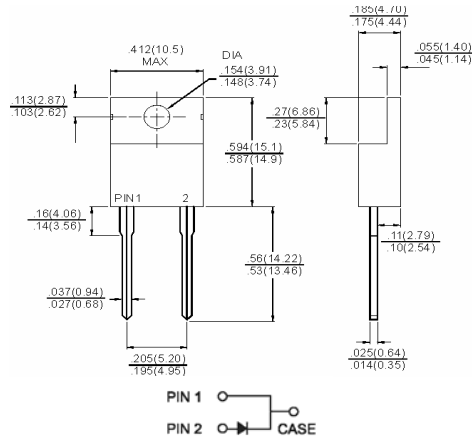

Features

- ✧ Plastic material used carries Underwriters Laboratory Classifications 94V-0
- ✧ Metal silicon junction, majority carrier conduction
- ✧ Low power loss, high efficiency
- ✧ High current capability, low forward voltage drop
- ✧ High surge capability
- ✧ For use in low voltage, high frequency inverters, free wheeling, and polarity protection applications
- ✧ Guardring for overvoltage protection
- ✧ High temperature soldering guaranteed: 260°C/10 seconds, 0.25" (6.35mm) from case



Mechanical Data

- ✧ Cases: JEDEC TO-220AC molded plastic body
- ✧ Terminals: Pure tin plated, lead free, solderable per MIL-STD-750, Method 2026
- ✧ Polarity: As marked
- ✧ Mounting position: Any
- ✧ Mounting torque: 5 in. - lbs. max
- ✧ Weight: 0.08 ounce, 2.24 grams

Dimensions in inches and (millimeters)

Maximum Ratings and Electrical Characteristics

Rating at 25 °C ambient temperature unless otherwise specified.

Single phase, half wave, 60 Hz, resistive or inductive load.

For capacitive load, derate current by 20%

Type Number	Symbol	MBR 1035	MBR 1045	MBR 1050	MBR 1060	MBR 1090	MBR 10100	MBR 10150	MBR 10200	Units
Maximum Recurrent Peak Reverse Voltage	V_{RRM}	35	45	50	60	90	100	150	200	V
Maximum RMS Voltage	V_{RMS}	24	31	35	42	63	70	105	140	V
Maximum DC Blocking Voltage	V_{DC}	35	45	50	60	90	100	150	200	V
Maximum Average Forward Rectified Current at $T_c=125^\circ\text{C}$	$I_{(AV)}$	10								A
Peak Repetitive Forward Current (Rated V_R , Square Wave, 20KHz) at $T_c=125^\circ\text{C}$	I_{FRM}	32								A
Peak Forward Surge Current, 8.3 ms Single Half Sine-wave Superimposed on Rated Load (JEDEC method)	I_{FSM}	150								A
Peak Repetitive Reverse Surge Current (Note 1)	I_{RRM}	1.0		0.5						A
Maximum Instantaneous Forward Voltage at: (Note 2) $I_F=10\text{A}, T_c=25^\circ\text{C}$ $I_F=10\text{A}, T_c=125^\circ\text{C}$ $I_F=20\text{A}, T_c=25^\circ\text{C}$ $I_F=20\text{A}, T_c=125^\circ\text{C}$	V_F	0.70 0.57 0.84 0.72	0.80 0.70 0.95 0.85.		0.85 0.71 — —		1.05 — — —		V	
Maximum Instantaneous Reverse Current @ $T_c=25^\circ\text{C}$ at Rated DC Blocking Voltage @ $T_c=125^\circ\text{C}$ (Note 2)	I_R	0.1								mA
		15		10		6.0				mA
Voltage Rate of Change (Rated V_R)	dV/dt	10,000								V/ μS
Typical Junction Capacitance	C_j	500								pF
Maximum Typical Thermal Resistance (Note 3)	$R_{\theta JC}$	3.0								$^\circ\text{C}/\text{W}$
Operating Junction Temperature Range	T_J	-65 to +150								$^\circ\text{C}$
Storage Temperature Range	T_{STG}	-65 to +175								$^\circ\text{C}$

- Notes:
1. 2.0us Pulse Width, f=1.0 KHz
 2. Pulse Test: 300us Pulse Width, 1% Duty Cycle
 3. Thermal Resistance from Junction to Case Per Leg with Heatsink Size of 2 in x 3 in x 0.25 in Al-Plate.

RATINGS AND CHARACTERISTIC CURVES (MBR1035 THRU MBR10200)

FIG.1- FORWARD CURRENT DERATING CURVE

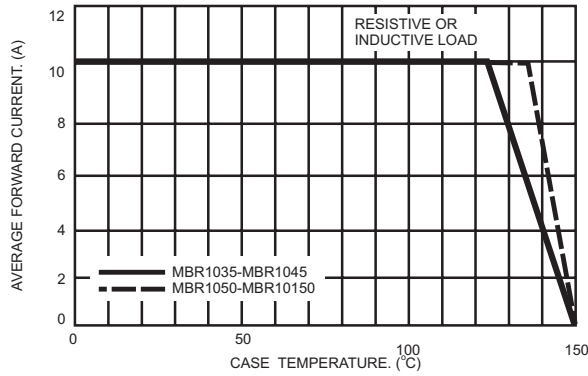

FIG.2- MAXIMUM NON-REPETITIVE FORWARD SURGE CURRENT

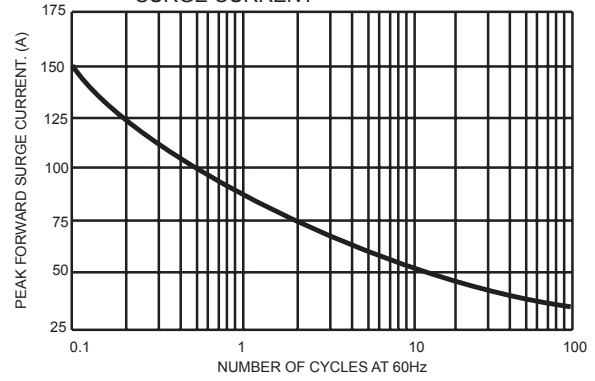

FIG.3- TYPICAL INSTANTANEOUS FORWARD CHARACTERISTICS

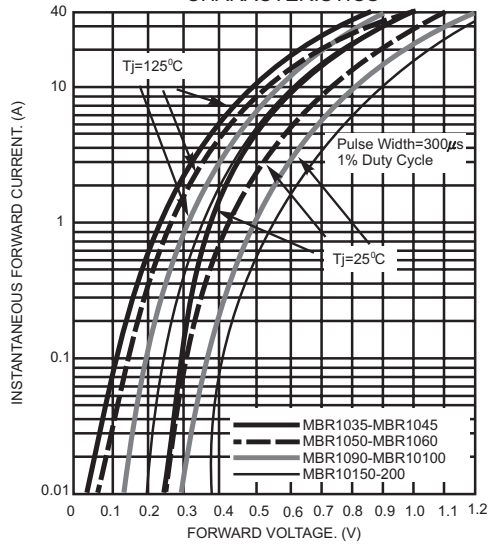

FIG.4- TYPICAL REVERSE CHARACTERISTICS

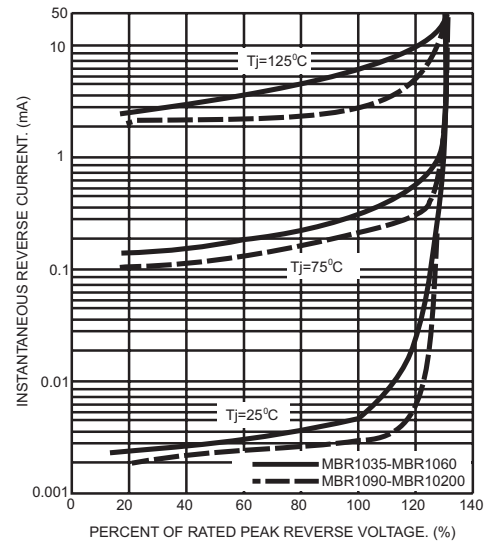

FIG.5- TYPICAL JUNCTION CAPACITANCE

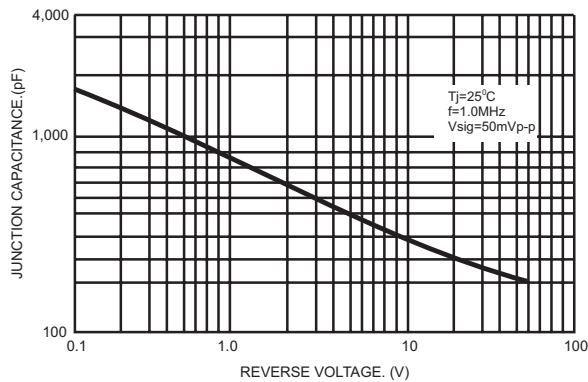

FIG.6- TYPICAL TRANSIENT THERMAL CHARACTERISTIC

