



WSN802GCA WSN802GPA

802.11g Wireless Sensor Network Modules

- **Small Size, Integral Antenna, Light Weight, Low Cost**
- **7.5 μ A Sleep Current Supports Battery Operation**
- **Timer and Event Triggered Auto-reporting Capability**
- **Analog, Digital, Serial and SPI I/O for Sensor Applications**
- **-40 to +85 °C Operating Temperature Range**
- **FCC, Canadian IC and ETSI Certified for Unlicensed Operation**

WSN802GCA and WSN802GPA transceiver modules are low cost, robust solutions for 802.11g sensor networks. The very low sleep current required by these modules makes long life battery operation practical. The WSN802G modules include analog, digital, serial and SPI I/O, providing the flexibility and versatility needed to serve a wide range of sensor network applications. WSN802GCA and WSN802GPA modules are easy to integrate, require no external antennas and are compatible with standard 802.11b/g access points.

WSN802G Absolute Maximum Ratings

Rating	Value	Units
Input/Output Pins Except ADC Inputs	-0.5 to +3.63	V
ADC Input Pins	-0.5 to 1.98	V
Non-Operating Ambient Temperature Range	-40 to +85	°C

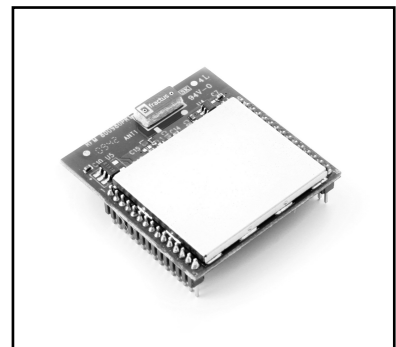

WSN802G Electrical Characteristics

Characteristic	Sym	Notes	Minimum	Typical	Maximum	Units
Operating Frequency Range			2401		2474	MHz
Spread Spectrum Method			Direct Sequence			
RF Chip Rate			11			Mcps
RF Data Rates			1, 2, 5.5 and 11			Mbps
Modulation Type			BPSK at 1 Mbps, QPSK at 2 Mbps, CCK at 5.5 and 11 Mbps			
Number of RF Channels				11		
RF Channel Spacing				5		MHz
Receiver Sensitivity, 8% PER:						
1 Mbps RF Data Rate				-92		dBm
2 Mbps RF Data Rate				-90		dBm
5.5 Mbps RF Data Rate				-84		dBm
11 Mbps RF Data Rate				-81		dBm
RF Transmit Power EIRP				10		mW
Antenna			Integral Chip Antenna			

WSN802G Electrical Characteristics

Characteristic	Sym	Notes	Minimum	Typical	Maximum	Units
ADC Input Range			0		1.8	V
ADC Input Resolution				10		bits
ADC Input Impedance			1			MΩ
PWM Output Resolution					16	bits
Data Serial Port Baud Rates			1.2, 2.4, 4.8, 9.6 (default), 19.2, 28.8, 38.4, 57.6, 76.8, 115.2, 230.4, 460.8, 921.6			kbps
Diagnostic Serial Port Baud Rates			1.2, 2.4, 4.8, 9.6 (default), 19.2, 28.8, 38.4, 57.6, 76.8, 115.2			kbps
Serial Peripheral Interface (SPI) Data Rate, Master Mode					11	Mbps
Serial Peripheral Interface (SPI) Data Rate, Slave Mode					2	Mbps
Digital I/O:						
Logic Low Input Level			-0.3		0.7	V
Logic High Input Level			2.24		V _{CC}	V
Input Pull Up Resistor			50		1000	KΩ
Logic Low Output Level			0		0.4	V
Logic High Output Level			2.4		V _{CC}	V
Power Supply Voltage Range	V _{CC}		+3		+3.63	Vdc
Power Supply Voltage Ripple					10	mV _{P-P}
Receive Mode Current					150	mA
Transmit Mode Current					200	mA
Sleep Mode Current				7.5		μA
WSN802GCA Mounting			Reflow Soldering			
WSN802GPA Mounting			Socket			
Operating Temperature Range			-40		85	°C
Operating Relative Humidity Range, Non-condensing			10		90	%



CAUTION: Electrostatic Sensitive Device. Observe precautions when handling.

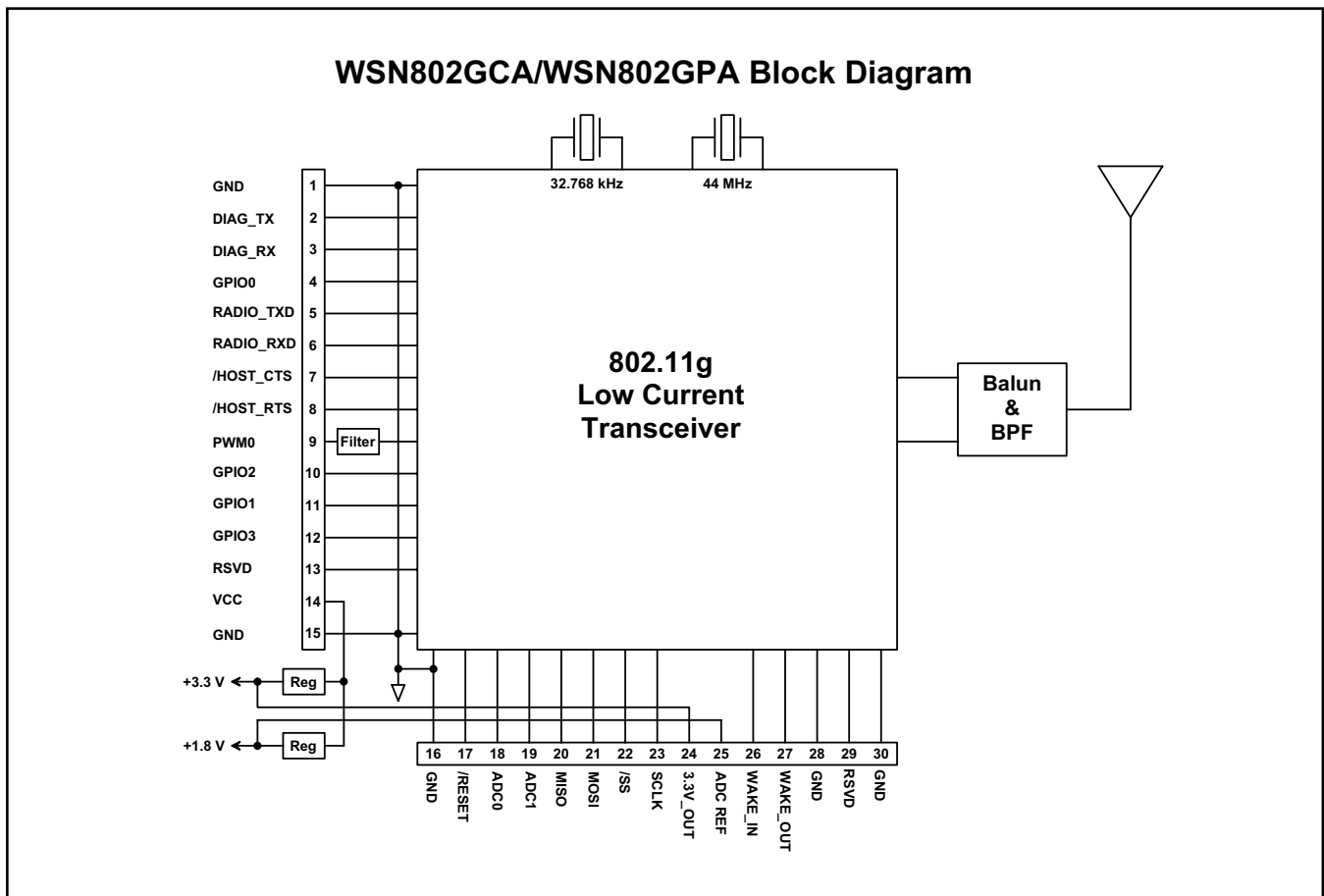

Figure 1

WSN802GCA/WSN802GPA Hardware

The WSN802GCA and WSN802GPA operate in the international 2.4 GHz ISM band over the frequency range of 2401-2474 MHz, with a nominal RF output power of 10 mW and a nominal antenna gain of 0 dBi. WSN802G modules support four standard 802.11g RF data rates - 1, 2, 5.5 and 11 Mbps.

The WSN802G transceiver module provides a variety of hardware interfaces. There are two serial interfaces, one for data and a second for diagnostics. The data port supports standard serial baud rates from 1.2 to 921.6 kbps, with optional hardware flow control. The diagnostic port supports standard baud rates from 1.2 to 115.2 kbps. The WSN802G also includes an SPI port that supports data rates up to 2 Mbps in slave mode, and up to 11 Mbps in master mode.

The WSN802G includes two 10-bit ADC inputs, one 16-bit PWM (DAC) output, and four general purpose I/O (GPIO) ports to support sensor network applications.

WSN802G modules with integral antenna are available in two mounting configurations. The WSN802GCA is designed for solder reflow mounting, and the WSN802GPA is designed for plug-in connector mounting.

Rev F WSN802G Firmware

The major firmware components in the WSN802G include the 802.11g stack and the application protocol. The WSN802G acts as a UDP client to a data and/or sensor application running on a network server.

The application protocol supports three operating modes: (1) sleeping sensor node with timer or interrupt auto-reporting, (2) sleeping serial data node with timer or interrupt wake-up and (3) always on sensor or serial data node with auto-reporting. Modes 1 and 2 take full advantage of the very low sleep current capability of the WSN802G. The module sleeps unless the WAKE_IN input is asserted or the *AutoReport* timer fires. A *Wake-Timeout* timer is provided to hold the module awake for a configurable period. The *Wake Timeout* timer is held in reset as long as WAKE_IN is asserted, serial data is being received, an RF packet is being sent or received, or if the module is uncommissioned.

The WSN802G asserts WAKE_OUT whenever it is awake to notify its external host. The module also sends an I/O status report automatically each time WAKE_IN is asserted, and/or each time the *AutoReport* timer fires.

WSN802G I/O Pad Descriptions

Pin	Name	I/O	Description
1	GND	-	Power supply and signal ground. Connect to the host circuit board ground.
2	DIAG_TX	O	Diagnostic serial port output.
3	DIAG_RX	I	Diagnostic serial port input.
4	GPIO0	I/O	Configurable digital I/O port 0. An internal weak pull up is provided when configured as an input.
5	RADIO_TXD	O	Serial data output from the radio.
6	RADIO_RXD	I	Serial data input to the radio.
7	/HOST_CTS	O	UART/SPI flow control output. The module sets this line low to indicate it is ready to accept data from the host on the RADIO_RXD or MOSI input. When the module sets this line high, the host must stop sending data.
8	/HOST_RTS	I	UART flow control input. The host sets this line low to allow data to flow from the module on the RADIO_TXD pin. When the host sets this line high, the module will stop sending data to the host.
9	PWM0	O	16-bit pulse-width modulated output 0 with internal low-pass filter. Filter is first-order, with a 159 Hz 3 dB bandwidth, 10K output resistance.
10	GPIO2	I/O	Configurable digital I/O port 2. An internal weak pull up is provided when configured as an input.
11	GPIO1	I/O	Configurable digital I/O port 1. An internal weak pull up is provided when configured as an input.
12	GPIO3	I/O	Configurable digital I/O port 3. An internal weak pull up is provided when configured as an input.
13	RSVD	-	Reserved pin. Leave unconnected.
14	VCC	I	Power supply input, +3.0 to +3.63 Vdc.
15	GND	-	Power supply and signal ground. Connect to the host circuit board ground.
16	GND	-	Power supply and signal ground. Connect to the host circuit board ground.
17	/RESET	I	Active low module hardware reset.
18	ADC0	I	10-bit ADC input 0. ADC full scale reading can be referenced to the module's +1.8 V regulated supply.
19	ADC1	I	10-bit ADC input 1. ADC full scale reading can be referenced to the module's +1.8 V regulated supply.
20	MISO	I/O	SPI master in, slave out function. This pin is an input when the module is operating as a master, and is an output when the module is operating as a slave.
21	MOSI	I/O	SPI master out, slave in function. This pin is an output when the module is operating as a master, and is an input when the module is operating as a slave.
22	/SS	I/O	SPI active low slave select. This pin is an output when the module is operating as a master, and an input when it is operating as a slave.
23	SCLK	I/O	SPI clock signal. This pin is an output when operating as a master, and an input when operating as a slave.
24	3.3V_OUT	O	Module's +3.3 V regulated supply, available to power external sensor circuits. Current drain on this output should be no greater than 50 mA.
25	ADC_REF	O	Module's +1.8 V regulated supply, used for ratiometric ADC readings. Current drain on this output should be no greater than 10 mA.
26	WAKE_IN	I	Active high interrupt input to wake the module from timer sleep. Can be used to wake module on event, etc.
27	WAKE_OUT	O	Active high output asserted when module wakes from timer sleep. Can be used to wake an external device.
28	GND	-	Connect to the host circuit board ground plane.
29	RSVD	-	Reserved pin. Leave unconnected.
30	GND	-	Connect to the host circuit board ground plane.

WSN802GCA Outline and Mounting Dimensions

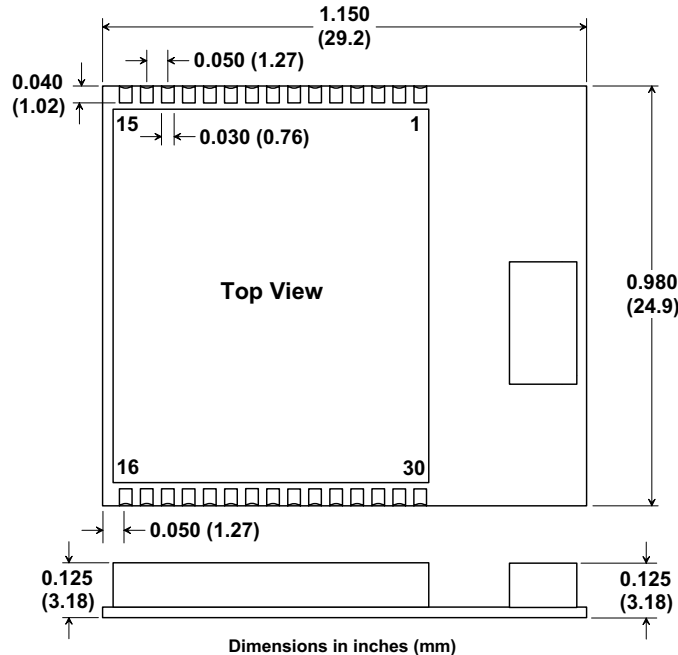

Figure 2

WSN802GCA Solder Pad Dimensions

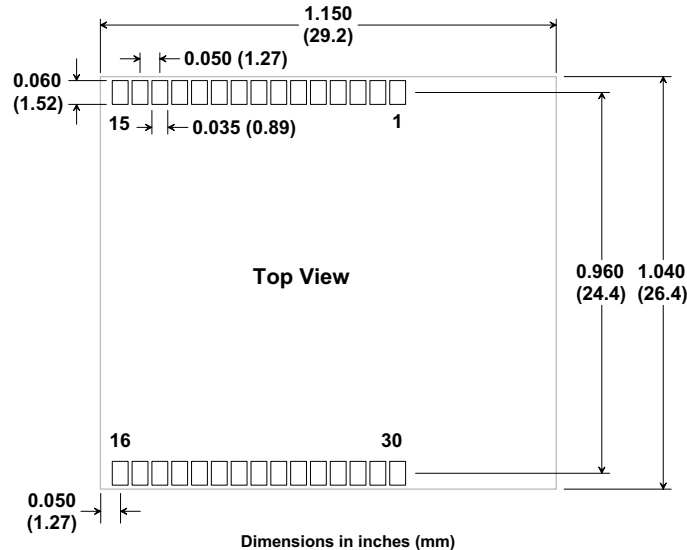

Figure 3

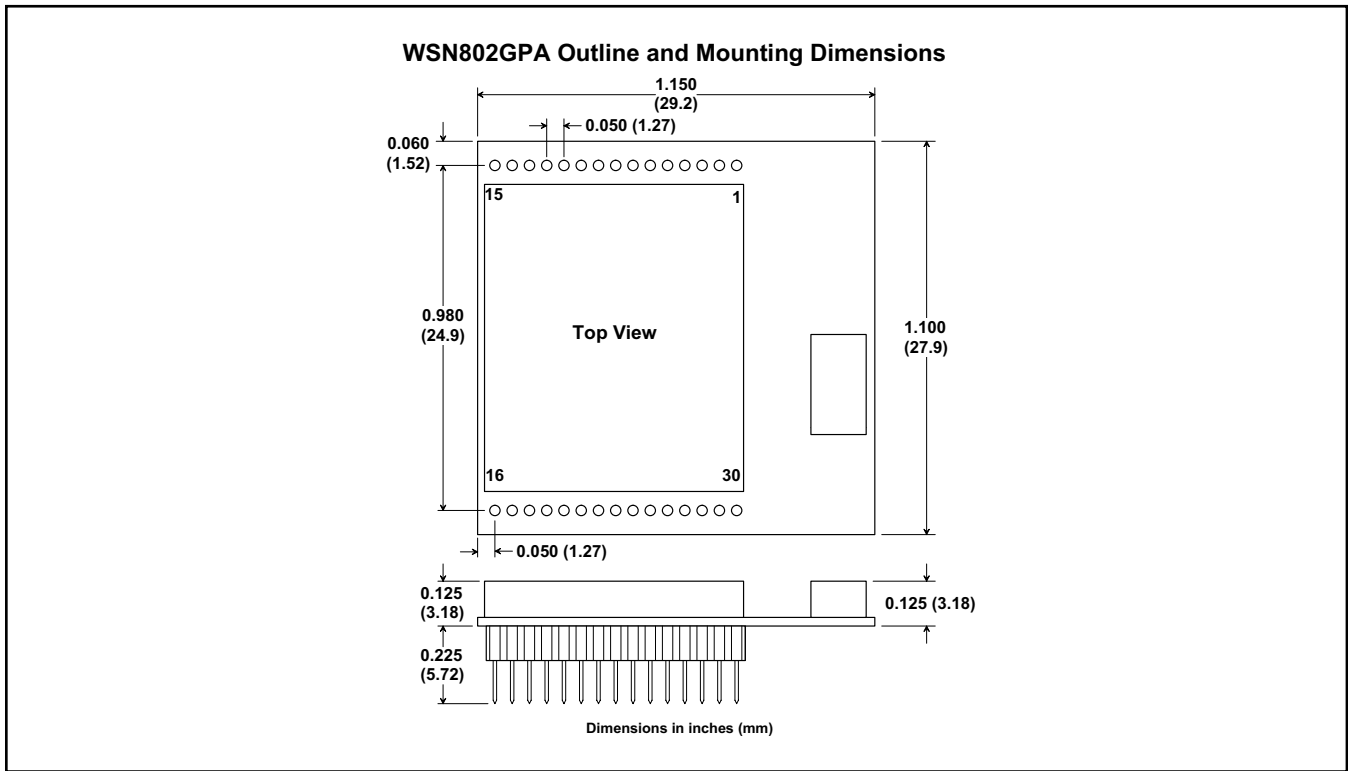

Figure 4

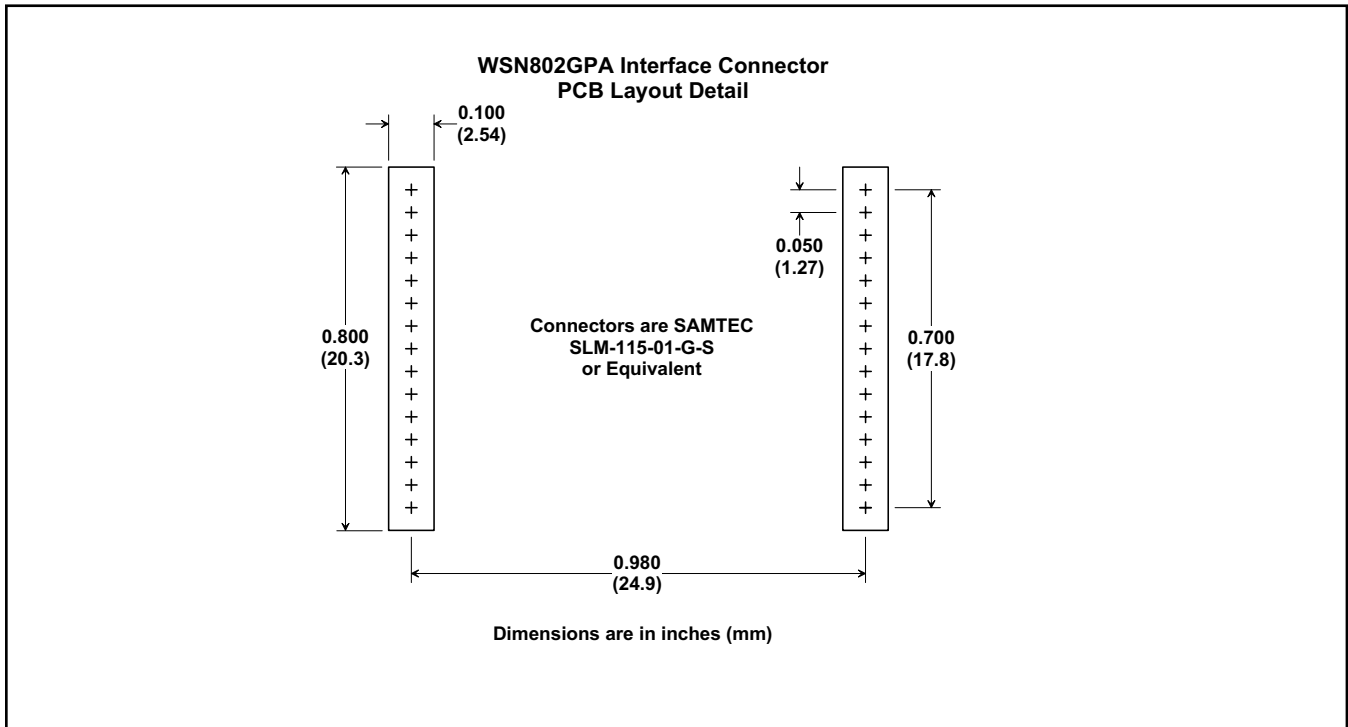

Figure 5

Note: Specifications subject to change without notice.

Part # M-0802-1005, Rev C