

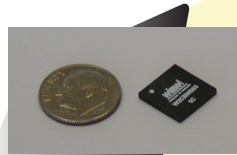

Wireless 2 Wireless



W2CBW003 - 802.11 b/g +Bluetooth™ System-in-Package

The W2SW0001 is a complete 802.11 b/g plus Bluetooth v2.0 + EDR radio solution based on the industry standard Marvell 8686 and Cambridge Silicon Radio architectures. Designed for handheld or portable warehousing/logistics, medical, and industrial applications, it is a complete WiFi/BT solution that includes an LDO for single rail operation, all crystals, all filtering, local memory for MAC address storage, and diagnostics capability. A full array of certifications have been performed on this device, making the certification process for the final systems design much easier and less costly. Full driver support is available for most OSs for the Marvell PXA family processors, as well as many other ARM-9 based processors using a Linux OS.

Applications

- Warehousing and logistics handhelds
- Automotive aftermarket
- Medical equipment
- Industrial handhelds
- M2M applications
- POS terminals
- Internet-enabled consumer devices
- VoFi and other smartphones
- WiFi enabled security cameras

Ordering Information

- W2CBW003-TR - WiFi/BT SIP, Tape and Reel
- W2CBW003-T - WiFi/BT SIP, Tray
- W2CBW003-001: Designates UART BT Int
- W2CBW003-SAM - WiFi/BT SIP Sample Pack
- W2CBW003-DEV - WiFi/BT SIP Evaluation Kit

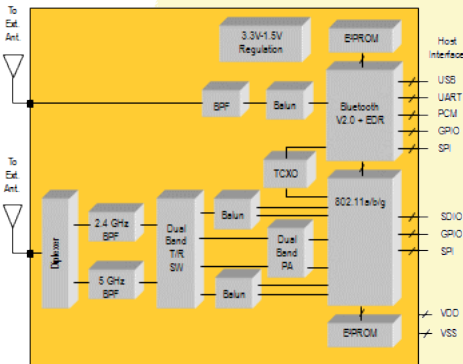

Features

- Small form factor SIP solution, 12mm x 12mm x 1.4mm, 100 Pin LGA, 1mm pitch
- Low power consumption and power save mode
- Full support for 802.11 e(QOS) and 802.11i (Security)
- Integrated RF-friendly LDO for single rail operation
- Integrated PA, EEPROM, Balun, and clocking
- Optimized front-end design for receive sensitivity, plus full coexistence support
- Full driver support for popular OSs for the Marvell PXA processor family, Linux support for many other ARM-9 based processors
- Includes both an SDIO and a GSPI interface for WiFi, and a UBS and UART interface for BT
- RoHS compliant
- 7 GPIOs for WiFi, 2 GPIOs for BT

Copyright 2008, WIZWI Inc.

WIZWI Inc. 2107 N First Street Ste 540, San Jose, CA 95131
USA Tel: +1 408 416 4000 FAX: +1 408 416 4201
www.wizwi.com

W2CBW003 - Specifications

Package Dimensions

- 12mm (L) x 12mm(W) x 1.4mm(H)

Package Type

- 100-pin BGA, 1 mm pitch

Power Ratings

- Supply Voltage : 3.3VDC, regulated to 1.5V
- Peak Current: 275 mA
- IEEE Power Save Mode: 10 mA
- Standby mode (both radios): 30 mA
- Deep Sleep Mode: 2mA

Temperature Range

- Operating: -20° C to +75° C
- Storage: -40° C to +85° C
- Humidity: 5% to 95%, Non-condensing

Data Rates

- CCK: 1,2,5.5, and 11Mb/s
- OFDM: 6,9,12,18,24,36,48, and 54 Mb/s
- BT v2.0: up to 1Mbps
- BT EDR: 2.3 Mbps

Interfaces - WiFi

- SDIO 1 bit and 4 bit, GSPI

Interfaces - BT

- USB (default) or UART

Transmit Power

- +15dBm typical for both 802.11 b and g
- BT v 2.0: +3dBm, EDR: -1dBm

Security

- WEP,TKIP, WPA and WPA2, AES/CCMP per 802.11 i
- CCX upon request

Baseband Modulation - WiFi

- 802.11g: OFDM
- 802.11b: DSSS/CCX

Baseband Modulation - BT

- v2.0: GFSK
- Bluetooth EDR: T/1/4 DQPSK, 8DPSK

Receiver Sensitivity - BT

- 1 Mb/s @ -84 dBm GFSK
- 2 Mb/s @ -87 dBm T/1/4 DQPSK
- 3 Mb/s @ -80 dBm 8DPSK

Receiver Sensitivity - WiFi

- 54 Mb/s @ -74 dBm OFDM
- 6Mb/s @ -90 dBm OFDM
- 11Mb/s @ -88 dBm CCK
- 1Mb/s @ -90 dBm DSSS

Quality of Service

- 802.11 e EDCF

Host Processors/OS With Driver Support

- Marvell PXA Family - most OSs
- Freescale i.MX21 and 31 - Linux OS, SDIO
- Samsung SC2443, 2412 - Linux (SDIO), WinCE

Copyright 2007, WIZWI Inc.

WIZWI Inc. 2107 N First Street Ste 540, San Jose, CA 95131
USA Tel: +1 408 416 4000 FAX: +1 408 416 4201
www.wizwi.com