

RF MODULES

www.panasonic.com/rfmodules

Snap[®]

RPA

ISM

Bluetooth[®]

Wireless Solutions for Less
Extended Range Capabilities
New Software Alternatives
Reduced Design Cycles
Extended Product Life Cycles



Modules That Exceed Expectations

Panasonic Electronic Components

1-800-344-2112

CUTTING EDGE SOLUTIONS

Panasonic Electronic Components provides powerful, highly flexible, cost effective RF Modules for a wide variety of wireless Personal Area Network (PAN) applications. New extended range products and small footprints combined with network firmware flexibility make Panasonic an industry leader in the development of cutting edge RF Module technology. Panasonic RF Module solutions provide:

Reduced Design Cycle

Panasonic RF Modules get your wireless products to market faster by greatly reducing the design-to-production path! RF hardware design, development, debugging and test, board layout, quality testing and certifications are all removed by choosing a Panasonic RF Module.

Extended Product Life Cycle

Panasonic RF Modules provide a constant footprint and pin out over several generations of integrated circuits to guard against the need to re-spin or redesign a wireless product to accommodate an IC that is no longer available. Extend the product life cycle of any wireless product by designing in a quality, Panasonic RF Module.

NEW Revolutionary Software Alternatives

The time or software resources required to learn network stacks and develop applications is daunting and expensive. Panasonic is partnered with several software developers for all of the major network protocols -- Bluetooth®, SNAP® and ISM. From fully developed Bluetooth® profiles to flexible AT commands and a powerful scripting language that allows applications to be developed quickly in Python, Panasonic can deliver an RF Module with firmware needed to make any project a success.

Wireless Solutions For Less

RF Modules from Panasonic can reduce the total cost of ownership for product development projects up to 50,000 units per year. Designing in an RF Module rather than a discrete wireless solution can reduce expensive development, test, certification and production resource requirements.

Introducing NEW Extended Range RF Modules

Panasonic announces long range additions to its SNAP® compatible wireless RF Module line. The NEW PAN4561 and PAN4566 break new ground by offering industry-leading link margins! See pages 12 and 14 for details!

Custom Solutions

In addition to the wide range of modules presented in this catalog, Panasonic also offers custom RF solutions. Contact your Panasonic sales representative for more information.

Exceptional Design In Support

Rely on Panasonic for all the value added services required to support designing in a standard or custom RF Module solution. Review the pages of this catalog for details on all the right module product platforms, development kit, antenna and software options available now from Panasonic!

Visit Us On The Web!

Visit www.panasonic.com/rfmodules, the only online source devoted entirely to RF Module technology, for everything you need to support your wireless project.

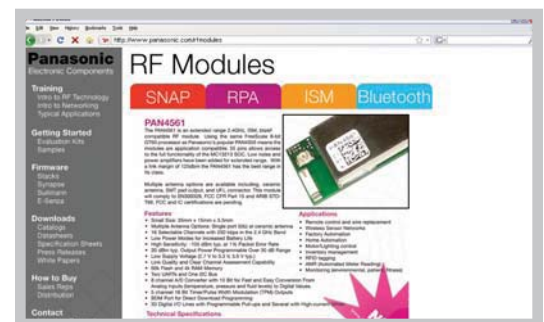

CONTENT REFERENCE

RF Module Technologies	4
Revolutionary Software Solutions	5
Selecting an RF Technology	6
Development Kits	7

	Model	Dimensions (mm)	Receiver Sensitivity/ Current	Max. Output Pwr/Current	Operating Temperature	Power Supply	Frequency Range	Number of I/Os	Interfaces	Max. Data Rate (kbps)	
SNAP[®]	PAN4555	16.4 x 12.6 x 2.2	-92 dBm 37 mA	0 dBm 30 mA	-40°C to +85°C	2.0 to 3.4 V	2.4 GHz	20	GPIO, UART	250	8
	PAN-4555ETU	39.3 x 19	-92 dBm 37 mA	0 dBm 30 mA	-40°C to +85°C	2.0 to 3.4 V	2.4 GHz	20	GPIO, UART	250	10
	NEW! PAN4561	35 x 15 x 3.5	-105 dBm 45 mA	20 dBm 202 mA	-40°C to +85°C	2.7 to 3.3 V	2.4 GHz	33	UART, GPIO, I2C	250	12
	NEW! PAN4566	35 x 15 x 3.5	-112 dBm 33 mA	20 dBm 189 mA	-40°C to +85°C	2.7 to 3.3 V	2.4 GHz	40	UART, SPI, I2C, GPIO	2000	14
	PAN4570	20.0 x 26.5 x 3.0	-98 dBm 35 mA	5 dBm 35 mA	-40°C to +85°C	2.1 to 3.6 V	2.4 GHz	17	GPIO, UART, SPI, I2C, ADC	250	16

RPA	NEW! PAN5375	29 x 15 x 4	-97 dBm 33 mA	20 dBm 30 mA	-40°C to +85°C	2.3 to 2.7 V	2.4 GHz	8	GPIO, SPI	2,100	18
------------	-------------------------	-------------	------------------	-----------------	----------------	--------------	---------	---	-----------	-------	-----------

ISM	PAN2350	20.3 x 14.8 x 4.2	-117 dBm 17 mA	5 dBm 33 mA	-40°C to +85°C	2.3 to 3.6 V	402 - 470 or 804 - 940 MHz	4	SPI	153.6	20
	PAN2355	8.0 x 8.2 x 1.9	-100 dBm 14.2 mA	10 dBm 19.7 mA	-40°C to +85°C	2.1 to 3.6 V	300 - 1000 MHz	4	SPI, GPIO, UART	500	22
	PAN2450	30.0 x 20.0 x 3.7	-114 dBm 18 mA	14 dBm 50 mA	-10°C to +55°C	2.3 to 3.6 V	868 - 915 MHz	16	GPIO, JTAG	153.6	24

Bluetooth[®]	NEW! PAN1455 PAN1555	14.75 x 13.5 x 2.85 18.75 x 13.5 x 2.85	-86 dBm	4 dBm	-40°C to +85°C	2.7 to 3.6 V	2.4 GHz	30	GPIO, USB, I2C	2100	26
------------------------------	-------------------------------------	--	---------	-------	----------------	--------------	---------	----	-------------------	------	-----------

RF MODULE TECHNOLOGIES

SNAP®

Based on the IEEE 802.15.4 standard, SNAP was developed for the purpose of sending small amounts of data, short distances, using very little power. The key feature of this technology is the ability to create a self healing, mesh network where nodes “talk” to each other in a way that gets a message to a desired end point using the best path. When not in use, nodes will “sleep” using extremely little power.

- Frequency: 2.4 GHz
- Encryption: Available
- Network Size: 64k
- Battery Life: Years
- Speed: 250 kB/s

RPA

Relative Position Awareness technology integrates wireless communication with ranging capabilities which can be used to develop location aware applications. These products use Nanotron’s unique wireless Chirp Spread Spectrum (CSS) communication technology that supports a freely adjustable center frequency with three non-overlapping channels. Applications include high value asset tracking, positioning in areas where GPS is unavailable i.e. in buildings or under ground.

- Frequency: 2.4 GHz
- Encryption: Available
- Network Size: 65K
- Battery Life: Years
- Speed: 2.1 MB/s

ISM

Industrial, Scientific, and Medical (ISM) radio band. Key benefits are reduced cost, proprietary (closed system) network, low power and various speeds of data transmission. If a system does not need to be open, this might be an economical way to transmit/receive data.

- Frequency: 315 MHz~2.4 GHz
- Encryption: Available
- Network Size: Unlimited
- Battery Life: Years
- Speed: Up to 2,000 kB/s

Bluetooth®

Based on IEEE 802.15.1, Bluetooth was developed for the purpose of sending larger amounts of data quickly from computers to PDAs to cell phones or other portable handheld devices. Key features include high data rate, frequency hopping, very small form factor and modest power consumption.

- Frequency: 2.4 GHz
- Encryption: Available
- Network Size: 8 Nodes
- Battery Life: Days
- Speed: 720 kB/s

Synapse and SNAP are registered trademarks of Synapse Wireless Inc.
Bluetooth is a registered trademark of Bluetooth SIG, Inc.

Synapse Wireless Mesh Network Protocol

Synapse® Wireless provides software for wireless machine communications focused on the mesh networking market. Synapse's SNAP® (Synapse Network Appliance Protocol) software is unprecedented in the industry. SNAP is an IEEE 802.15.4 based auto-forming, multi-hop, mesh network stack core combined with a virtual machine layer for running application code. SNAP runs preinstalled on Panasonic's RF modules. Synapse's impressive technology is not complicated to use. There is no setup required nor complex embedded programming skills needed; making time to market fast and product development a SNAP!

- Self-healing mesh network.
- Instant-ON: communicate within milliseconds of power-up.
- Simple, powerful scripting language (Python based).
- Customize applications and interactively upload scripts over-the-air.
- Supports full mesh with sleeping (low power) modes.
- Remote Procedure Call (RPC) support, peer-to-peer among all nodes.
- Supports AES-128 encryption
- All devices are peers - every node can bridge, route, and sleep.
- Supports bridging to other networks (TCP/IP) with transparent RPC calls.
- Scripts have full pin-level access to hardware.

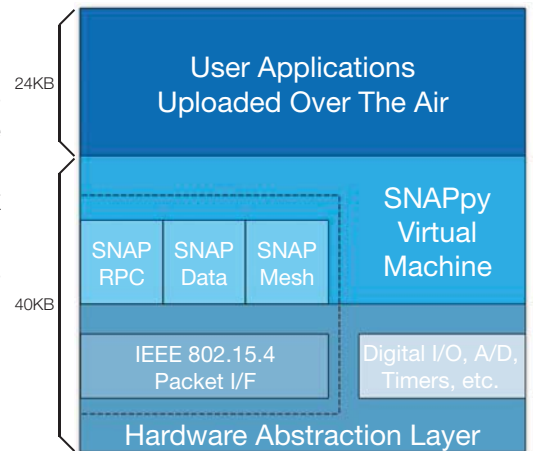

The SNAP Software Stack

- Flexible "Switchboard" for routing data between logical ports:
 - UARTs
 - Transparent Wireless Data
 - STDIO
 - Packet-mode Async Serial
- Virtually unlimited network

E-Senza

E-Senza's SN55 is an industry leading wireless device networking firmware that allows instant sensor, device and meter integration into a seamless low-power IEEE 802.15.4 Wireless Personal Area Network using simple AT commands.

The SN55 provides real-time mesh networking capabilities coupled with ease of programming and device interfacing with the option of future migration path to standards like Wireless HART or ISA SP100.

SN55 integrates and hides the lower level complexities of the wireless device networks and provides an easy and intuitive user interface. The network layer supports several device profiles, routing mechanism, store-and-forward mechanism, and other services.

With the help of the SN55 firmware, an end-to-end wireless device networking solution that addresses both current needs and simultaneously the needs of the future by providing a migration path to future standards can be built. The greatest benefit of the SN55 is its modular framework which can provide whatever the application needs.

SN55 provides the following features:

- Multi-Hopping and True Mesh-Networking
- Optimized Battery Management For Wireless Nodes
- Event-Reporting Mechanism With Push Technology
- Support For Multiple Device Profiles For Industry Interfaces And Devices

SELECTING AN RF TECHNOLOGY

Range

What is the maximum distance between nodes?

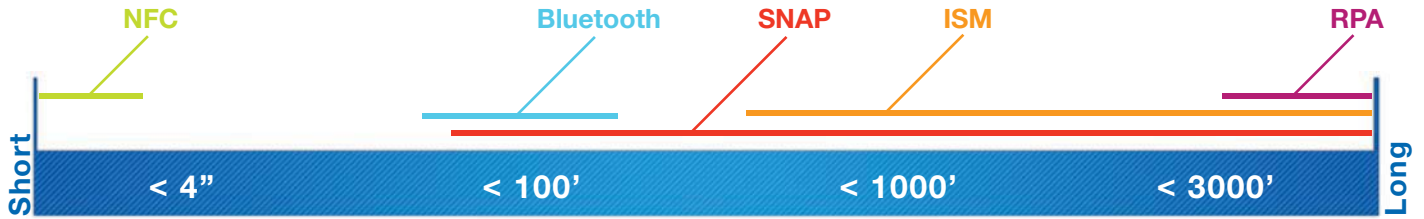

BATTERY LIFE

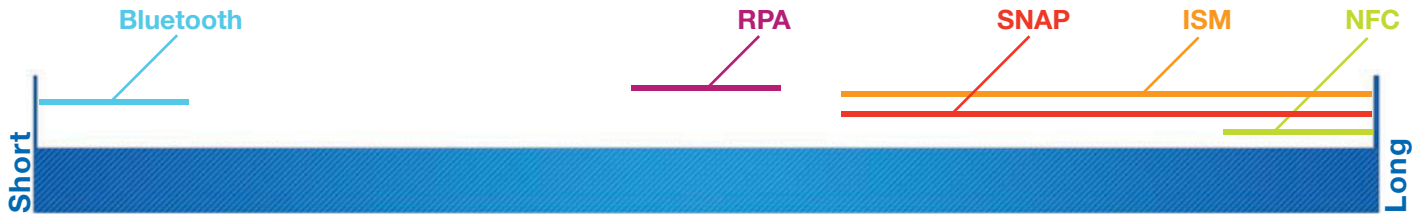

Data Load

How much data needs to be transmitted?



Compatibility

Does your network need to communicate with other company's product?



DEVELOPMENT KITS

Panasonic Development Kits provide a software and hardware testing environment. The unique mother/daughter board design reduces development costs by allowing a single motherboard to be used to test multiple Panasonic modules. Kits include two or more modules and test boards, software, cabling, and documentation.

PAN45xx Development Kit

This is Panasonic's SNAP evaluation kit for the PAN4555/4561/4566 series (p/n EVAL_PAN45xx). The kit comes with software, documentation, power supplies, antennae, RS232 and USB ports, external battery holder, and both RS232 and USB serial cables. Although not shown in the photo, the kit also comes with one pair of AA batteries. The kit also contains three different kinds of nodes:

- One Bridge Demonstration Node
- One End Device Demonstration Node
- One Prototype Node

The EVAL_PAN45xx series evaluation kit is similar in function to other available evaluation kits. All kits contain, cabling, documentation, software, RS232 ports, regulators and a minimum of two nodes.



Evaluation kits for other RF modules vary in their appearance and features. Visit www.panasonic.com/rfmodules for additional information.

Typical Development Kit Contents*

Panasonic's other Wireless Module technology evaluation kits come with the following:

- 2 Mother Boards
- 2 Daughter Boards
- 2 Antennae
- 2 RS-232 Cables
- Battery Adaptors
- Documentation
- Range Test & Simple-Lighting Applications

* Variations in Kit Types Will Occur

Please note that there is limited availability for ISM device development kits.

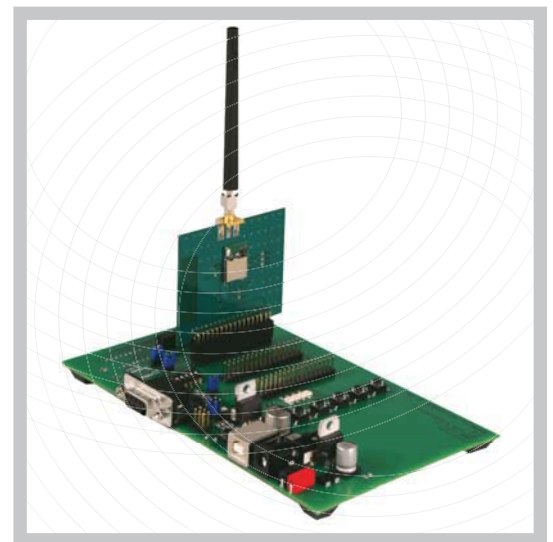

Development Kits are available for most modules. Please check with your local Panasonic sales representative for availability.

The PAN4555 module is a short range, low power, 2.4 GHz ISM band transceiver. It includes a complete 802.15.4 physical layer (PHY) modem. It is designed for the IEEE 802.15.4 wireless standard and microcontroller (MCU). The module also has a reference oscillator which provides a cost effective solution for short-range data links and networks. Several firmware options are available, modules can be configured from simple point-to-point proprietary devices to complex mesh networks. Optional Synapse SNAP firmware provides a highly flexible, industry leading solution for mesh networking with a complete network development environment. This module complies with EN300328, FCC CFR Part 15 and ARIB STD-T66 standards.

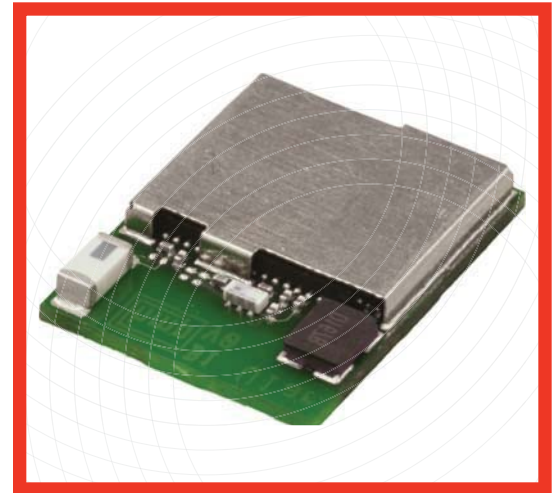

Product Performance:

- Very Small Size: 12.2mm X 16.4mm X 2.2mm (200mm²)
- 2 Antenna Options: Single Port 50Ω Or Ceramic Antenna
- 16 Selectable Channels With 250 Kbps In The 2.4 GHz Band
- Low Power Modes For Increased Battery Life
- High Sensitivity Of -92 dBm Typical At 1% Packet Error Rate
- 0 dBm Typical Output Power Programmable Over A 30 dB Range
- Low Supply Voltage: 2.0 V To 3.4 V, 2.7 V Typical
- Operating Temperature Range: -40°C To +85°C
- Link Quality And Clear Channel Assessment Capability
- 60k Flash And 4k RAM Memory
- 4 Channel A/d Converter With 10 Bit Adc For Fast And Easy Conversion From Analog Inputs (Temperature, Pressure And Fluid Levels) To Digital Values.
- 3 Channel 16 Bit Timer/Pulse Width Modulation (Tpm) Outputs
- BDM Port For Direct Download Programming
- In Total 20 Digital I/O Lines With Programmable Pull-ups And Few With High-current Driver
- FCC, IC, & ETSI Approved

Applications:

- Remote Control And Wire Replacement In Industrial Systems Such As Wireless Sensor Networks
- Factory / Home Automation And Motor / Lighting Control
- Inventory Management And RFID Tagging
- Automated Meter Reading
- Monitoring (Environmental, Patient or Fitness)

Part Numbers:

Part Number	Description
ENWC9A08A3EF	Ceramic Antenna
ENWC9A09N4EF	RF Out On SMD Pads
ENWC9A08A2EF	Ceramic Antenna, AT Command Set, coordinator
ENWC9A09C2EF	RF Out on SMD Pads, AT Command Set, coordinator
ENWC9A08A2EF	Ceramic Antenna, AT Command Set, Node
ENWC9A09C2EF	RF Out on SMD Pads AT Command Set
ENWC9A08A4EF	Ceramic Antenna, SNAP
ENWC9A09C4EF	RF Out on SMD Pads, SNAP
EVAL_PAN4555	Evaluation Kit For The PAN4555 Module

Dimensions & Pin Layout:

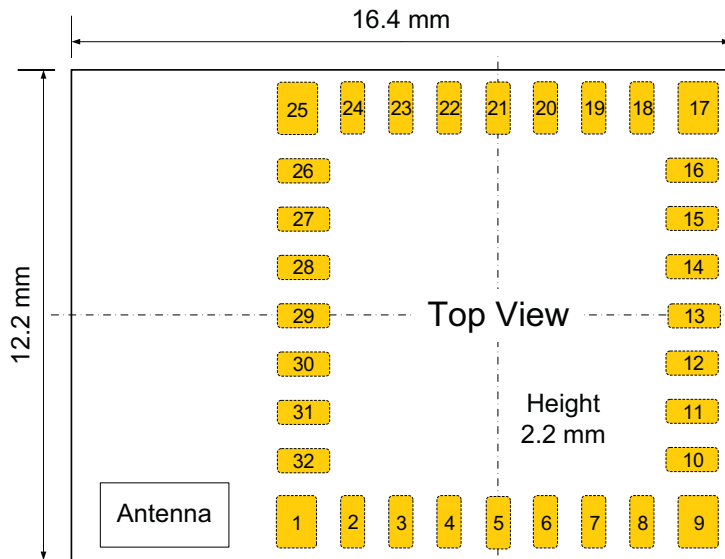

Pin No.	Pin Name	Pin No.	Pin Name
1, 9, 17, 25, 31	GND	18	PTC5
		19	PTC3
2 to 4	PTB0 to 2	20	PTC2
5	PTB7	21 to 22	PTE0 to 1
6	VREFH	23	VDDA
7	PTA7	24	Vcc
8	PTA5	26	Vcc
10	PTA6	27	RESET
11	PTG0/BKGD	28	PTD6
12 to 13	PTG1 to 2	29	PTD4
14	CLKO	30	PTD2
15 to 16	PTC0 to 1	32	EXTANT

Note: The pin names of the module and the internal MC13213 are equivalent.

Technical Specifications:

Parameter	Value	Condition / Notes
Receiver Sensitivity	-92 dBm typical	For 1% packet error rate
Output Power	0 dBm	Maximum
Power Supply	2.0 V to 3.4 V	Single supply, 2.7 V typical
Power Control Range	30 dB	
Maximum Data Rate	250 kbps	Over The Air
Current Consumption		Output power nominal value
Receive Mode	37 mA typ.	No CLKO
Transmit Mode	30 mA typ.	
Idle Mode	500 μ A typ.	
Doze Mode	35 μ A typ.	
Hibernate Mode	1 μ A typ.	
Off Mode	<1 μ A typ.	
Operating Temperature Range	-40°C to +85°C	

Notes:

All parameters are valid for Vdd = 2.7V And Tamb = 25°C.

Freescale's MC13213 is used in the module. SMAC, MAC Or Freescale Bee-stack.

Mode definitions and transition times for saving battery life can be seen in the data sheet MC1321X.

The derivative MC13212 and MC13211 are available on request.

The PAN4555ETU Easy-To-Use (ETU) module is the easiest way to make the first step into the mesh networking world. It provides pinned I/O for testing and prototyping with a 0.1" (2.5mm) perf or stripboard. No special designs are needed to get this module working. This module is a short range, low power, 2.4 GHz ISM band transceiver which includes a complete 802.15.4 physical layer (PHY) modem. Designed for the IEEE 802.15.4 wireless standard and an independent micro-controller (MCU) with a reference oscillator to provide a cost effective solution for short-range data links and networks. Software is included.



Product Performance:

- Pin Pitch: 2.54mm / 0.1"
- 16 Selectable Channels With 250 Kbps In The 2.4 GHz Band
- Low Power Modes For Increased Battery Life
- High Sensitivity Of -92 dBm Typical At 1% Packet Error Rate
- 0 dBm Typ. Output Power Programmable Over A 30 dB Range
- Low Supply Voltage: 2.0 V To 3.4 V, 2.7 V Typical
- Operating Temperature Range: -40°C To +85°C
- Link Quality And Clear Channel Assessment Capability
- 60k Flash And 4k RAM Memory
- 4 Channel A/d Converter With 10 Bit Adc For Fast And Easy Conversion From Analog Inputs (Temperature, Pressure And Fluid Levels) To Digital Values
- 3 Channel 16 Bit Timer/pulse Width Modulation (Tpm) Outputs
- BDM Port For Direct Download Programming
- In Total 20 Digital I/O Lines With Programmable Pull-ups And Few With High-current Driver
- FCC, ETSI, IC Approved

Applications:

- Remote Control And Wire Replacement In Industrial Systems Such As Wireless Sensor Networks
- Factory / Home Automation And Motor / Lighting Control
- Inventory Management And RFID Tagging
- Automated Meter Reading
- Monitoring (Environmental, Patient or Fitness)

Part Numbers:

Part Number	Description
EVAl_PAN4555ETU	PAN4555 Development Module, 2.4 GHz

Dimensions & Pin Layout:

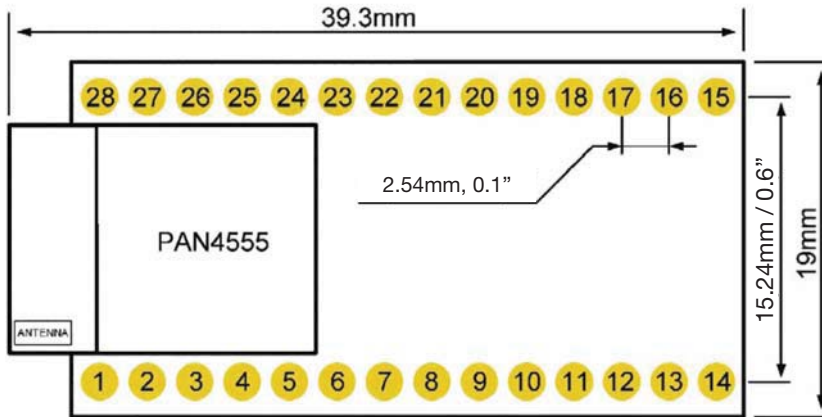

Top View

Fits into normal 2.54mm / 0.1" pitch

Pin No.	Pin Name	Pin No.	Pin Name
1 to 3	PTB0 to 2	17	PTD4
4	PTB7	18	PTD6
5	VREFH	19	RESET
6	PTA7	20	PTC5
7	PTA5	21 to 22	PTC0 to 1
8	PTA6	23	PTC3
9	PTG0/BKGD	24	PTC2
10 to 11	PTG1 to 2	25 to 26	PTE0 to 1
12	CLKO	27	VDDA
13 to 15	GND	28	Vcc
16	PTD2		

Note: The pin names of the module and the internal MC13213 are equivalent.

Technical Specifications:

Parameter	Value	Condition / Notes
Receiver Sensitivity	-92 dBm typical	For 1% Packet Error Rate
Output Power	0 dBm	Maximal
Power Supply	2.0 V to 3.4 V	Single Supply, 2.7 V Typical
Power Control Range	30 dB	
Maximum Data Rate	250 kbps	Over The Air
Current Consumption		Output Power Nominal Value
Receive Mode	37 mA typ.	No CLKO
Transmit Mode	30 mA typ.	
Idle Mode	500 μ A typ.	
Doze Mode	35 μ A typ.	
Hibernate Mode	1 μ A typ.	
Off Mode	<1 μ A typ.	
Operating Temperature Range	-40°C to +85°C	

Notes:

All parameters are valid for VDD = 2.7V and Tamb = 25°C.

Freescale's MC13213 is used in the module. SMAC, MAC or Freescale Bee-Stack.

Mode definitions and transition times for saving battery life can be seen in the data sheet MC1321X.

Also the derivative MC13212 and MC13211 are available on request.

The PAN4561 is an extended range 2.4GHz, ISM, RF module. Modules may be configured from simple point-to-point proprietary devices to complex mesh networks by choosing from different firmware options. Optional Synapse SNAP firmware provides a highly flexible, industry leading solution for mesh networking with a complete network development environment. The module uses the same Freescale eight bit GT60 processor as Panasonic's popular PAN4555 making the two products application compatible. The PAN4561 has 55 pins allowing access to the full functionality of the MC13213 SOC. Low noise and power amplifiers have been added to the PAN4561 for extended range. With a maximum transmit power of 20dBm and receive sensitivity of -105dBm this module has a link margin of 125dBm, giving it the best range in its class.



Multiple antenna options are available including, ceramic antenna, SMD pad output, and U.FL connector. This module will comply to EN300328, FCC CFR Part 15 and ARIB STD-T66. FCC and IC certifications are pending.

Product Performance:

- Small Size: 35mm X 15mm X 3.5mm
- 3 Antenna Options: Single Port 50Ω, Ceramic Antenna or SMD Output
- 16 Selectable Channels With 250 Kbps In The 2.4 Ghz Band
- Low Power Modes For Increased Battery Life
- High Sensitivity: -105 dBm Typical At 1% Packet Error Rate
- 20 dBm Typical Output Power Programmable Over 30 dB Range
- Low Supply Voltage: 2.7 V To 3.3 V, 3.0 V Typical
- Operating Temperature Range: -40°C To +85°C
- Link Quality And Clear Channel Assessment Capability
- 60k Flash And 4k RAM Memory
- Two UARTs And One I²C Bus
- 8 Channel A/D Converter With 10 Bit For Fast And Easy Conversion From Analog Inputs (Temperature, Pressure And Fluid Levels) To Digital Values.
- 5 Channel 16 Bit Timer/Pulse Width Modulation (Tpm) Outputs
- BDM Port For Direct Download Programming
- 33 Digital I/O Lines With Programmable Pull-Ups And Several With High-Current Driver

Part Numbers:

Part Number	Description
ENWC9A22A1EF	8 bit, LNA, PA, with Ceramic Antenna, No SW
ENWC9A22C1EF	8 bit, LNA, PA, with RF Out on SMD Pads, No SW
ENWC9A22B1EF	8 bit, LNA, PA, with U. FL Ant Connector, No SW
ENWC9A22A2EF	8 bit, LNA, PA, Ceramic Ant, SN55 FW
ENWC9A22B2EF	8 bit, LNA, PA, U.FL Connector, SN55 FW
ENWC9A22C2EF	8 bit, LNA, PA, SMD RF Out, SN55 FW
ENWC9A22A4EF	8 bit, LNA, PA, Ceramic Ant, SNAP FW
ENWC9A22C4EF	8 bit, LNA, PA, SMD RF Out, SNAP FW
ENWC9A22B4EF	8 bit, LNA, PA, U.FL Connector, SNAP FW
EVAL_PAN4561	Evaluation Kit For The PAN4561 Module

Applications:

- Factory Automation
- Home Automation
- Motor/Lighting Control
- Inventory Management
- Remote Control And Wire Replacement For Industrial Systems (Wireless Sensor Networks)
- RFID Tagging
- Automated Meter Reading
- Monitoring (Environmental, Patient, Fitness)

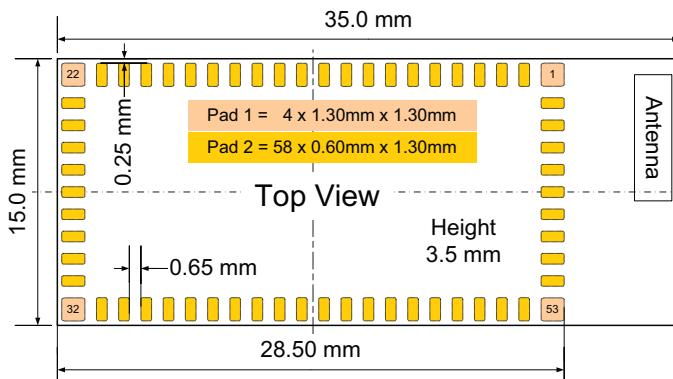
Dimensions & Pin Layout:**Note:**

The pin names of the module and the internal MC1321x names fit to each other.
All unmentioned pins are not connected and must be left open.

Pin No.	Pin Name	Pin No.	Pin Name
1, 22, 32, 56 to 62	GND	23 / 24	Vcc
2 to 5	TPM2CH1-4 (PTD4-7)	25 / 26	32 kHz Xtal
6	TPM2CH2 (PTD2)	27	/Reset
8	UART2 TxD (PTC0)	28	CLKO
9	UART2 RxD (PTC1)	30	BKGD/MS (PTG0)
10	I ² C SDA (PTC2)	33	VDDA
11	I ² C SCL (PTC3)	34 to 41	KBIO-7 (PTA0-7)
12 to 19	ADC7-0 (PTB7-0)	42 to 45	PTC7-4
20	ADC Ref. H	46	UART1 TxD (PTE0)
21	ADC Ref. L	47	UART1 RxD (PTE1)
		52	/PA_PwrDn
		53 to 54	GND
		55	50 Ohm RF

Technical Specifications:

Parameter	Value	Condition / Notes
Receiver Sensitivity	-105 dBm typ.	For 1% Packet Error Rate
Output Power	20 dBm	Maximal
Power Supply	2.7 V ~ 3.3 V	Single Supply, 3.0 V Typ.
Power Control Range	30 dB	
Maximum Data Rate	250 kbps	Over The Air
Current Consumption		Output Power Nominal Value
Receive Mode	45 mA typ.	
Transmit Mode	202 mA typ.	
Idle Mode	1.6 mA typ.	
Doze Mode	50 μ A typ.	No CLKO
Hibernate Mode	16 μ A typ.	
Off Mode	2 μ A	
Operating Temperature Range	-40°C to +85°C	

Notes:

All parameters are valid for VDD = 2.7V and Tamb = 25°C.

Freescale's MC13213 is included with the module, SMAC, MAC or Freescale Bee-Stack. There is no additional license fee per module by using the Freescale Bee-Stack, only a one time general support fee (\$500) for the Bee-Stack to be paid to Freescale.

Mode Definitions and Transition Times for saving battery life can be seen in the data sheet MC1321x. The derivative MC13212 and MC13211 as well as a non-PALNA version are available on request.

Maximum ratings shown for Tx power and Rx sensitivity, typical ratings may be lower.

The PAN4566 is the latest addition to Panasonic's family of mesh networking modules. This third generation platform combines a 32 bit ARM7 core micro-controller with a 2.4GHz transceiver. The PAN4566 has both low noise and power amplifiers for long range applications. To maximize efficiency, Tx power is programmable over a 30dB range. With a maximum output power of 20dB and a receive sensitivity of -112dB, this module has a link margin of 132dB, giving it the best range in its class.

Multiple antenna options are available including, ceramic antenna, SMT pad output, and U.FL connector. This module will comply to EN300328, FCC CFR Part 15 and ARIB STD-T66. FCC and IC certifications are pending.



Product Performance:

- Small Size: 35mm X 15mm X 3.5mm
- 128k Flash, 80k ROM And 96k RAM Memory
- Powerful 32-bit AR7TDMI-S Core
- 2 Antenna Options: Single Port 50Ω Or Ceramic Antenna
- 16 Selectable Channels With 250/2000 Kbps In 2.4 Ghz Band
- Low Power Modes For Increased Battery Life
- High Sensitivity: -112 dBm Typical At 1% Packet Error Rate
- 20 dBm Typical Output Power Programmable Over A 30 dB Range
- Low Supply Voltage: 2.7v To 3.3v, 3.0v Typ. - 2.0 To 3.6v Without PA/INA
Optional: On-board Buck-converter
- Operating Temperature Range: -40°C To +85°C
- Link Quality And Clear Channel Assessment Capability
- Two Full UARTs With Flow Control, SPI And I²C
- 4 Channel A/D Converter With 12 Bit For Fast And Easy Conversion From Analog Inputs
- 4 Channel 16 Bit Timer/pulse Width Modulation Outputs
- JTAG Port For Debugging
- Flash Memory Access Over UART/SPI
- 40 Digital I/O Lines With Programmable Pull-Ups, Partially With High-Current Drivers

Applications:

- Factory Automation
- Home Automation
- Motor/Lighting Control
- Inventory Management
- Remote Control And Wire Replacement For Industrial Systems (Wireless Sensor Networks)
- RFID Tagging
- Automated Meter Reading
- Monitoring (Environmental, Patient, Fitness)

Part Numbers:

Part Number	Description
ENWC9A24A3EF	PAN4566, 32 bit, LNA, PA, With Ceramic Antenna
ENWC9A24N4EF	PAN4566, 32 bit, LNA, PA, With RF Out On SMD Pads
ENWC9A24N2EF	PAN4566, 32 bit, LNA, PA, With U.FL Antenna Connector
EVAL_PAN4566	Evaluation Kit For The PAN4566 Module

Dimensions & Pin Layout:

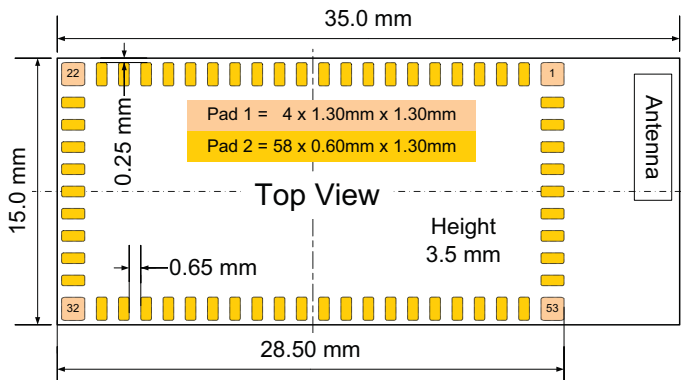

Note: The pin names of the module and the internal transceiver names are equivalent.

Pin No.	Pin Name	Pin No.	Pin Name
1, 22, 32, 56 to 62	GND	27	/Reset
2 to 5	Timer0-3 GPIO8-11	28 to 31	JTAG GPIO46-49
6 to 9	UART 2 GPIO21-19	33	NC
10 / 11	I ² C GPIO13-12	34 to 41	KB17-0 GPIO29-22
12 to 15	SSI GPIO0-3	42 to 45	SPI GPIO4-7
16 to 19	ADC3-0 GPIO33-30	46 to 49	UART 1 GPIO14-17
20	ADC Ref. H	50	Ant2 GPIO43
21	ADC Ref. L	51	Ant1 GPIO42
23 / 24	Vcc	52	/PA_PwrDn
25 / 26	32 kHz Xtal	53 to 54	GND
		55	50 Ohm RF

Technical Specifications:

Parameter	Value	Condition / Notes
Receiver Sensitivity	-112 dBm typ.	For 1% Packet Error Rate
Output Power	20 dBm	Maximal
Power Supply	2.7 V ~ 3.3 V	Single Supply, 3.0 V Typ.
Power Control Range	30 dB	
Maximum Data Rate	250 kbps	Over The Air, Proprietary 2 Mbps Optional
Current Consumption		Output Power Nominal Value
Receive Mode	33 mA typ.	
Transmit Mode	189 mA typ.	
Idle Mode	770 μ A typ.	
Doze Mode	74 μ A typ.	
Hibernate Mode	19 μ A typ.	
Off Mode	2 μ A	
Operating Temperature Range	-40°C to +85°C	

Note:

All parameters are valid for VDD = 3.0V and Tamb = 25°C.

Samples available summer 2009.

The PAN4570 is a short range, low power, 2.4 GHz ISM band transceiver using the Ember EM250 single chip solution for mesh networking. With IEEE 802.15.4 compliance, 16-bit ZAP2b micro-processor, on-board reference oscillators, and optimized RF front-end circuitry, the PAN4570 provides everything needed for a full mesh network solution. A reliable application programming interface and Ember's EmberZNet stack can easily create application profiles.

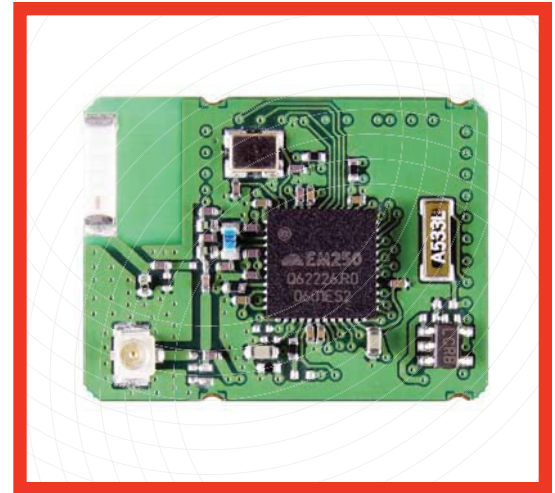

Product Performance:

- 128k Flash And 5k SRAM Memory
- 3 Antenna Options: Plug, 50 Ω SMD Port Or Ceramic Antenna
- 16 Selectable Channels With 250 kbps In The 2.4 GHz Band
- 3 Different Power Modes For Increased Battery Life
- High Sensitivity Of -97 dBm Typical At A 1% Packet Error Rate
- +3 dBm Output Power (+5 dBm In Boost Mode)
- Low Supply Voltage: 2.1 V To 3.6 V, 3.0 V Typical
- Small Size: 20.0mm X 26.5mm X 3.0mm
- Onboard Low Power Regulator
- Operating Temperature Range: -40°C To +85°C
- Link Quality And Clear Channel Assessment Capability
- All Of The 17 GPIO Of EM250 Are Available At The Module Pads, Which Are Multiplexed To GPIO, UART, SPI, I²C Or Up To Four Analog Inputs To An ADC And Two Timer Waveform Outputs
- Critical Portions Of IEEE 802.15.4-2003 Plus A First-line Filter For Non-Intended Packets Are Realized In Hardware, Thus Reducing The Workload On The μ c
- FCC Certified

Applications:

- Remote Control And Wire Replacement In Industrial Systems Such As Wireless Sensor Networks
- Factory / Home Automation And Motor / Lighting Control
- Inventory Management And RFID Tagging
- Automated Meter Reading
- Monitoring (Environmental, Patient or Fitness)

Part Numbers:

Part Number	Description
ENWC9A02A3E	PAN4570, Mesh Networking Module With Ceramic Antenna
ENWC9A03N2E	PAN4570, With U.FL Antenna Connector
ENWC9A04N4E	PAN4570, With RF Out On SMD Pads
EVAL_PAN4570	Evaluation Kit For The PAN4570 Module

Dimensions & Pin Layout:

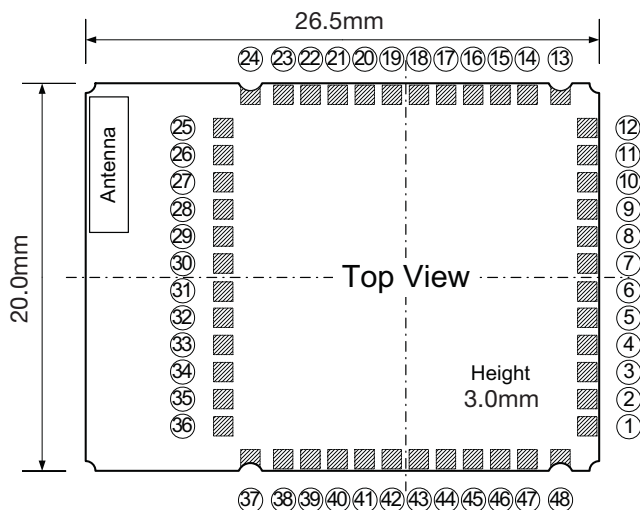

Pin No.	Pin Name	Pin No.	Pin Name
1	VBAT	27	SIF_MOSI
2	REG_out	28	SIF_LOADB
3	Reset	29	n.c.
4	OSC32A	30 to 37	GND
5	OSC32B	38	RF
6 to 12	GPIO 0 to 6	39, 48	GND
13,24	GND	40	VC1
14 to 23	GPIO 7 to 16	41 to 45	n.c.
25	SIF_CLK	46	Reg_EN
26	SIF_MISO	47	Reg_IN

Note:

Access to the programming interface pins 25, 26, 27, 28, 1, and 3 has to be provided on the application board.

Technical Specifications:

Parameter	Value	Condition / Notes
Receiver Sensitivity	-96 dBm typ. - Normal -97 dBm typ. - Boost	For 1% packet error rate
Output Power	3 dBm 5 dBm	Normal Boost Mode On
Power Supply	2.1 V to 3.6 V	3.0 V typical
Error Vector Magnitude	15% Typical 35% Boost	Typical as defined by IEEE802.15.4-2003
Maximum Data Rate	250 kbps	Over The Air
Current Consumption		
Total Rx Current	35.5 mA typ.	@ max Tx power, boost mode off (on) max, with 32.768KHz osc running max, with internal RC osc running
Total TX Current	35.5 (41.5) mA typ.	
Deep Sleep Mode	1.5 μ A	
Deep Sleep Mode	1.0 μ A	
Operating Temperature Range	-40°C to +85°C	

Notes:

All parameters are valid for VDD = 3.0V and Tamb = 25°C.
The data stated above is preliminary data.

The PAN5375 module operates in the worldwide, license-free, ISM band at 2.4GHz and ensures reliable communication through its unique chirp transmission technology. nanoLOC offers on-chip point-to-point ranging accuracy of better than one to two meters while offering robust, reliable data communication with superior transmission range. With its unique ranging capability, nanoLOC can measure the link distance between two nodes. Thus, nanoLOC supports location awareness applications including location based services (LBS), enhanced RFID, and asset tracking (2D/3D RTLS). Ranging is performed during regular data communication and does not require additional infrastructure, power, and/or bandwidth. For more accurate ranging, a high precision mode is provided. This module complies with ETSI standards EN300328, EN301489 and EN60950.

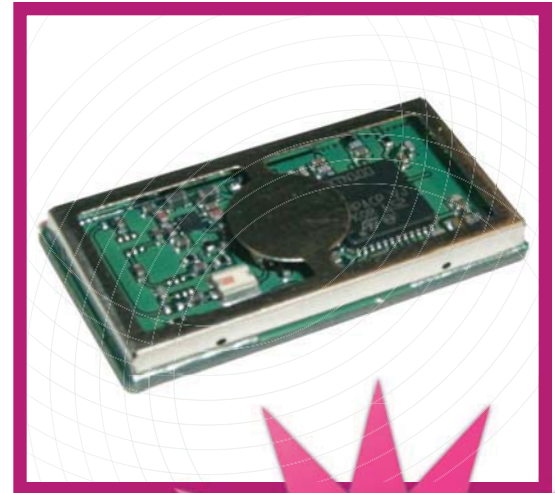

NEW!

Product Performance:

- Built-in Distance Estimation Capability
- Modulation Technique: Chirp Spread Spectrum (CSS)
- FDMA Support: 7 channels, 3 non-overlapping
- Data Rates: 2.1 Mbps
- Adjustable Output Power: -33dBm ~ +20dBm
- Small Size: 29mm x 15mm x 4mm
- Operating Temperature Range: -40°C to +85°C
- Integrated Fast SPI Interface (32Mbps)
- Integrated MAC Controller With FEC, CRC Checking
- Automatic Retransmission And Acknowledgement

Applications:

- Location Awareness Applications
- Active RFID / Asset Tracking
- Enabling 2D/3D Real-Time Location Systems
- Security
- Industrial Monitoring And Control
- Medical Applications

Part Numbers:

Part Number	Description
ENW59616N3EF	PAN5375, nanoLOC
EVAL_PAN5375	Evaluation Kit For The PAN5375 Module

Dimensions & Pin Layout:

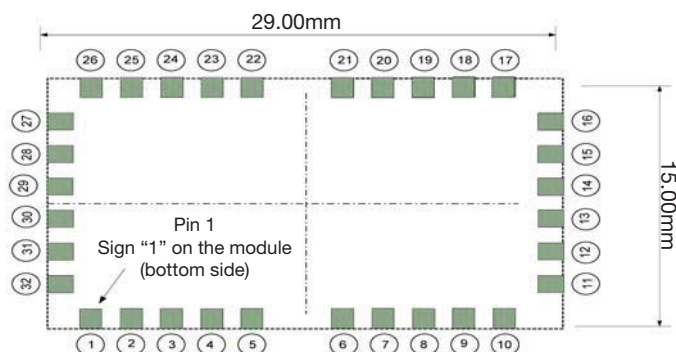

Pin No.	Pin Name	Pin No.	Pin Name
1, 3, 4, 14 - 20, 22, 23, 25, 27 - 29	GND	10	DIIO2
2	V _{CC}	11	DIIO1
5	SPICLK	12	DIIO0
6	μC V _{CC}	13	P_ON_Reset
7	SPITxD	21	V _{CC}
8	SPIrxD	24	Antenna
9	DIIO3	26	TX_/RX
		30	μC_IRQ
		31	μC_Reset
		32	SPISSN

Technical Specifications:

Parameter	Value	Condition / Notes
Receiver Sensitivity	-97 dBm	
Output Power	max. 20 dBm	
Power Control Range	-33 dBm ~ +20 dBm	
Maximum Data Rate	2 Mbps	
Power Supply	2.3 V to 2.7 V	
Current Consumption		
Receive Mode (2Mbps mode)	Starting at 33mA	@ 0 dBm
Transmit Mode (2Mbps mode)	30mA	
Standby Mode w/ Active RTC	1.2 μA	
Range		
Outdoor Maximum	300 m	@ 10 dBm
	1000 m	@ 20 dBm
Indoor Typical	40 m	@ 0 dBm
	Up to 60 m	@ 20 dBm
Operating Temperature Range	-40°C to +85°C	

Notes:

All parameters are valid for V_{CC} = 2.7V and T_{amb} = 25°C.

The nanoLOC TRX transceiver from Nanotron Technologies is used in this module.

The PAN2350 is a low power UHF narrowband transceiver, specially designed for both ISM and SRD band frequencies. It is easily programmed for operation at a number of other frequencies. This small module offers a low cost, fully integrated solution for many wireless applications. The PAN2350 is made for applications where a narrow band bidirectional data transfer function is needed but can also be used in wide band bidirectional applications.

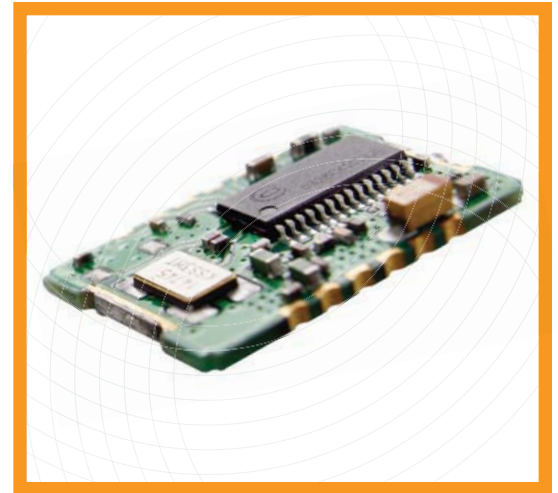

Product Performance:

- Maximum Data-rate Up To 153.6 kBaud (NRZ Mode)
- Low Power Consumption- Frequency Range 804 - 940 MHz or 402 - 470 MHz
- High Sensitivity, Up To 121 dBm For A 12.5 kHz Channel
- Programmable Output Power Up To 10 dBm
- Low Supply Voltage: 2.3 V to 3.6 V
- Small Size: 14.8mm x 20.3mm x 4.2mm
- Operating Temperature Range: -40°C to +85°C
- Digital RSSI and Carrier Sense Indicator
- Suitable For Frequency Hopping Systems
- Single Port Antenna Connection
- Complies With EN 300 220 And FCC CFR47 Part 15

Applications:

- Wireless Alarm And Security Systems
- RKE - Two-Way Remote Keyless Entry
- Home Automation Systems
- Automated Meter Reading
- Low Power Telemetry
- Toys

Part Numbers:

Part Number	Description
ENW59604NC1	PAN2350, 868 MHz, 4.8KBPS, Tx 5 dBm
ENW59604NC2	PAN2350, 868 MHz, 153.6KBPS, Tx 5 dBm
ENW59604NC3	PAN2350, 433 MHz, 4.8KBPS, Tx 10 dBm
ENW59604NC4	PAN2350, 434 MHz, 156.8KBPS, Tx 5 dBm
EVAL_PAN2350	Evaluation Kit For The PAN2350 Module

Dimensions & Pin Layout:

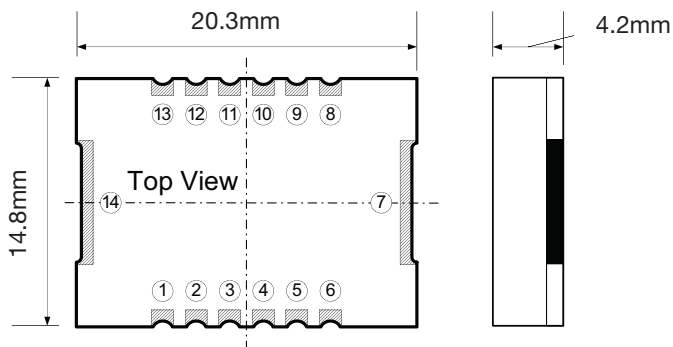

Pin No.	Pin Name
1	LOCK
2,4,5,7,14	GND
3	ANT
6	VCC
8	PSEL
9	PCLK
10	PDI
11	PDO
12	DCLK
13	DIO

Technical Specifications:

Parameter	Value	Condition / Notes
Receiver Sensitivity (BER=10 ⁻³) 433 MHz 868 MHz	-117 dBm -116 dBm	12.5 kHz channel width, FSK@2kHz, 2.4kBaud, Manchester coded
Output Power 433 MHz 868 MHz	-20 to +10 dBm -20 to +5 dBm	Delivered to 50 Ω load. The output power is programmable.
RSSI Dynamic Range	63 dBm range	Digital Output
PLL Lock Time (Rx/Tx turn time) 12.5 kHz channel width, 433 MHz 25 kHz channel width, 868 MHz	1.3 ms 1.1 ms	Up to 1MHz frequency step to within ±1kHz
PLL turn-on time from power down mode with crystal oscillator running 12.5 kHz channel width, 433 MHz 25 kHz channel width, 868 MHz	4.8 ms 2.5 ms	Time from writing to registers to PLL lock
Power Down Mode	0.2 μA typ.	Oscillator Core Off
Current Consumption (Receive Mode 433 / 868 MHz)	16.9 / 17.6 mA typ.	25 kHz channel width. Lower current can be achieved at other settings
Current Consumption (Transmit Mode 433 / 868 MHz) P=3mW (5dBm)	16.8 / 33.0 mA typ.	Delivered to 50 Ω load. The output power is programmable.
Operating Temperature Range	-40°C to +85°C	

Notes:

All parameters belong to VCC = 3.0V, Tamb = 25°C
Chipcon's CC1020 is used in this module.

This extremely compact and multi-functional module is intended for the ISM frequency bands at 868 and 915 MHz with other frequencies between 300 and 1000 MHz available on request. This wireless transceiver can be linked to a wide range of devices including home appliances and keyless entry through SPI. Programming the vast functionalities is done via SPI or UART. The PAN2355 is made for all applications where a wide band bidirectional data transfer with high speed is needed. It has a small size with a 8 x 8.2mm footprint and very low power consumption and is ideal for battery driven applications.

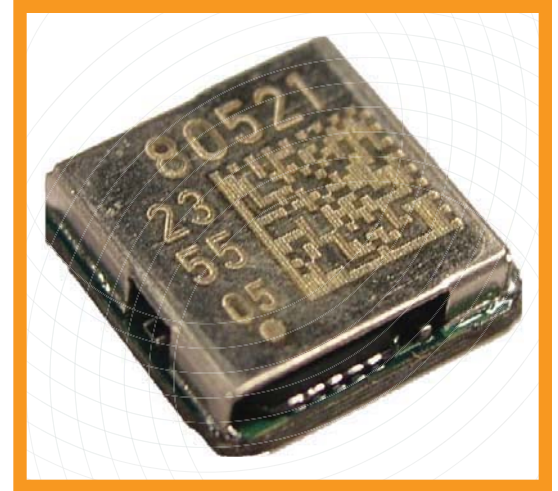

Product Performance:

- Programmable Data-Rate Up To 500 kBaud (NRZ Mode)
- Very Low Current Consumption
- Frequency Range 300 - 1000 MHz
- High Sensitivity, Typical -100 dBm at 2.4 kBaud, Manchester
- Programmable Output Power: -30 dBm to +10 dBm
- Low Supply Voltage: 2.1V to 3.6V
- Operating Temperature Range: -40°C to +85°C
- Small Size: 8.0mm x 8.2mm x 1.9mm, Including Shielding (Only 65.6 mm²)
- Digital RSSI Output
- Single Port 50 Ω Antenna Connection
- Programmable Frequency in 400 Hz Steps Makes Crystal Temperature Drift Compensation Possible

Applications:

- RKE - Two-Way Remote Keyless Entry
- Home Automation Systems
- Automated Meter Reading
- Low Power Telemetry
- Toys
- Remote Control Systems

Part Numbers:

Part Number	Description
ENW59611N3A	PAN2355, 868~915MHZ, 156.8KBPS, Tx 10 dBm
EVAL_PAN2355	Evaluation Kit For The PAN2355 Module

Dimensions & Pin Layout:

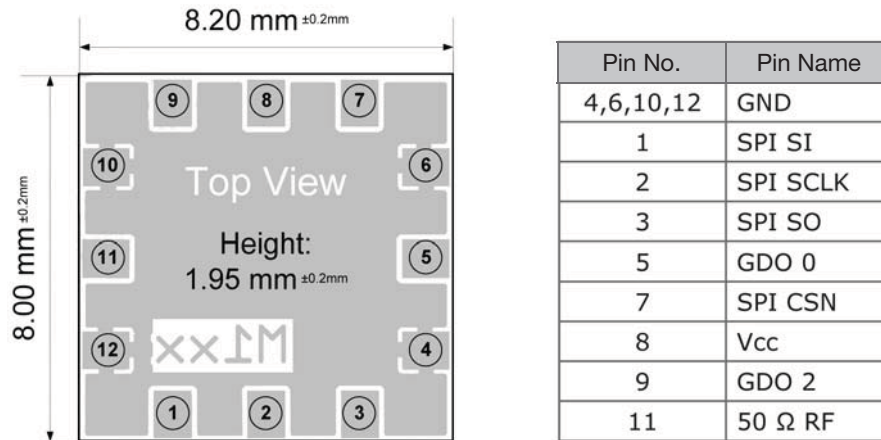

Technical Specifications:

Parameter	Value	Condition / Notes
Receiver Sensitivity, at 2.4 kbps, 2-FSK at 250 kbps, 2-FSK	-100 dBm -85 dBm	
Output Power	-30 to 10 dBm	Delivered to 50 Ω load. The output power is programmable.
RSSI Dynamic Range	-136 to -8 dBm	
PLL Lock Time (Rx/Tx turn time)	10 μs	For 1x IF frequency step
PLL turn-on time, crystal oscillator on in power down mode	80 μs	Crystal oscillator running
Power Down Mode	900 nA typ.	Standby with WOR enabled
Current Consumption (Receive Mode @ 2.4 kbps)	14.2 mA typ.	Current is programmable and can be increased for improved sensitivity
Current Consumption (Transmit Mode) P=3mW (5dBm)	19.7 mA typ.	Delivered to 50 Ω load.
Operating Temperature Range	-40°C to +85°C	

Notes:

All parameters are valid for VDD = 3.0V, Tamb = 25°C and 868MHz
Maximum output power is 10dBm. All other frequencies, e.g. 315 MHz, 433 MHz and 915MHz are also available on request.

The PAN2450 module is a low power UHF transceiver, with a completely integrated (autonomous) micro-controller and a highly efficient power amplifier. It is designed for ISM and SRD band frequencies. It can be easily programmed for operations at other frequencies. The modem complies with EN 300-220 and FCC CFR47 part 15 and offers a low cost solution for many ISM-applications. It's an optimal solution for all applications where a narrow band and wide band bidirectional data transfer function is required. It can be customized for various power levels, channel spacing and frequency needs.



Product Performance:

- Maximum Data-rate:
 - Up to 153.6 kBaud (NRZ Mode, Wide Band Applications)
 - Up to 19.2k Baud (NRZ Mode, Narrow Band Applications)
- Low Power Consumption
- Frequency Range 868 - 915 MHz (std)
- High Sensitivity, Up To -114 dBm for a 12.5 kHz Channel
- Programmable Output Power From 0 To 14 dBm
- Low Supply Voltage: 2.3 V to 3.6 V Typ. 3.0 V
- Small Size: 20.0mm x 30.0mm x 3.7mm
- Operating Temperature Range: -10°C to +55°C
- Digital RSSI And Carrier Sense Indicator
- Suitable For Frequency Hopping Systems
- Single Port Antenna Connection
- Complies With ETSI EN 300 220 And FCC CFR47 Part 15 And ARIB STD-T67

Applications:

- Wireless Alarm and Security Systems
- RKE - Two-way Remote Keyless Entry
- Home Automation Systems
- Automated Meter Reading
- Low Power Telemetry
- Toys
- Remote Control Systems

Part Numbers:

Part Number	Description
ENW59602ND1	PAN2450, 868~915MHZ, 4.8KBPS, Tx 14dBm
EVAL_PAN2450	Evaluation Kit For The PAN2450 Module

Dimensions & Pin Layout:

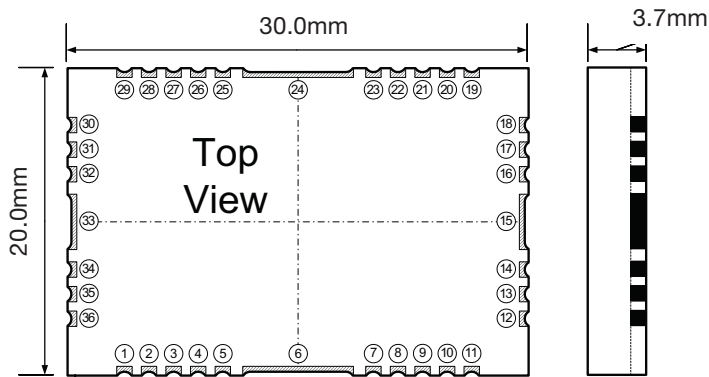

Pin No.	Pin Name	Pin No.	Pin Name
1,3,4,6,15, 24,26,28-36	GND	14	RST/NMI
2	VCC	16	P2.1
5	P1.6	17	P2.2
7	P1.7	18	P3.0
8	P1.5	19	P3.3
9	P1.4	20	P3.2
10	P1.2	21	P3.1
11	P1.1	22	P2.4
12	TEST	23	P3.4
13	P2.5	25	P3.5
		27	ANT

Technical Specifications:

Parameter	Value	Condition / Notes
Receiver Sensitivity, (BER=10 ⁻³) 868 MHz	-114 dBm	12.5 kHz channel width, FSK@2kHz, 2.4 kBaud, Manchester coded
Output Power 868 MHz	-0 to +14 dBm	Delivered to 50 Ω load. The output power is programmable.
RSSI Dynamic Range	63 dBm range	Digital output
PLL Lock Time (Rx/Tx turn time) 25 kHz channel width, 868 MHz	1.1 ms	Up to 1 MHz frequency step to within ±1kHz
PLL turn-on time, From power down mode with crystal oscillator running, 25 KHz channel width, 868 MHz	2.5 ms	Time from writing to registers to PLL lock
Power Down Mode	802 μA typ.	Oscillator core off, depends on the power down mode from the μC MSP430. Can be reduced with a new layout.
Current Consumption (Receive Mode 868 MHz)	18 mA typ.	25 kHz channel width
Current Consumption (Transmit Mode) 868 MHz P=25mW (14dBm)	50 mA typ.	Delivered to 50 Ω load. The output power is programmable.
Operating Temperature Range	-10°C to +55°C	

Notes:

All parameters belong to Vcc = 3V and Tamb = 25°C.

Texas Instruments μC MSP430F1232, Chipcon's CC1020 and a small power amplifier are used in this module.

Integrating Bluetooth communication in to your final product has never been easier. The new PAN1455/1555 Bluetooth module series include on-board microcontrollers that optionally include multiple BT profiles, including SPP, HSP, HFP and HDP.

The new PAN1455/1555 Bluetooth module series are based upon Cambridge Silicon Radio's BlueCore6-ROM (BC06). The PAN1555 includes an integrated ceramic antenna while the PAN1455 is excellent for projects requiring an external antenna. These modules are compatible with the Bluetooth Specification - 2.0 + Enhanced Data Rate (EDR) up to 3Mbps/s. The products deliver greater simplicity of use, lower power consumption and enhanced security. PAN1455/1555 Bluetooth module series are 100% footprint compatible with their predecessors the PAN1450/1550, are backward compatible with older Bluetooth devices (back to version 1.1) and do not require qualification.



Product Performance:

- Fully Qualified Bluetooth v2.0 +EDR
- Dimensions:
 - PAN1455 - 18.75mm x 13.5mm x 2.85mm
 - PAN1555 - 22.75mm x 13.5mm x 2.85mm
- Full Product Qualification (Bluetooth, CE, FCC, IC)
- Operating Temperature Range: -40°C to +85°C
- Supply Voltage Range: 2.7V to 3.6V, typ. 3.3V
- Profiles: GAP, SDAP, SPP, HID And HDP Available, Others Can Be Supported On Request
- CSR BlueCore6-ROM Inside
- Cortex-M3 ST32F103 Core For Embedded Profiles Or Application Software
- Fast Connection Setup
- Support For 802.11 Coexistence

Interfaces:

- UART (Programmable Baud Rate), USB, I²C, SPI And ADC
- 18 GPIOs For Individual Usage For Your Embedded Software
- All Bluetooth Data Rate Up To 2178kbps Asymmetric
- PCM Interface Master/Slave supporting 13 or 16 bit linear, 8 bit μ -law Or A-law Codecs And CVSD Transcoders On Up To 3 SCO Channels.

Radio Features:

- High Sensitivity Design (-86 dBm Typ.)
- Full 8 To 128 bit Encryption
- Power Control And RSSI, Hold, Park And Sniffmode
- Support For Very Low Power Modes: Sleep and Deep sleep

Part Numbers:

Part Number	Description
ENW89815A3KF	PAN1555, CSR, BC06, SPP Profile, Integrated Antenna
EVAL_PAN1555	Evaluation Kit For The PAN1555 Module
ENW89815C3KF	PAN1455, CSR, BC06, SPP Profile, Integrated Antenna
EVAL_PAN1455	Evaluation Kit For The PAN1455 Module

Applications:

- Printers & Printer Adapters
- Access Points
- Wireless Sensors
- Industrial Applications
- Cable Replacement
- Personal Digital Assistants (PDAs)
- Personal Navigation Devices
- Automotive Applications
- Medical Applications



Block Diagram:

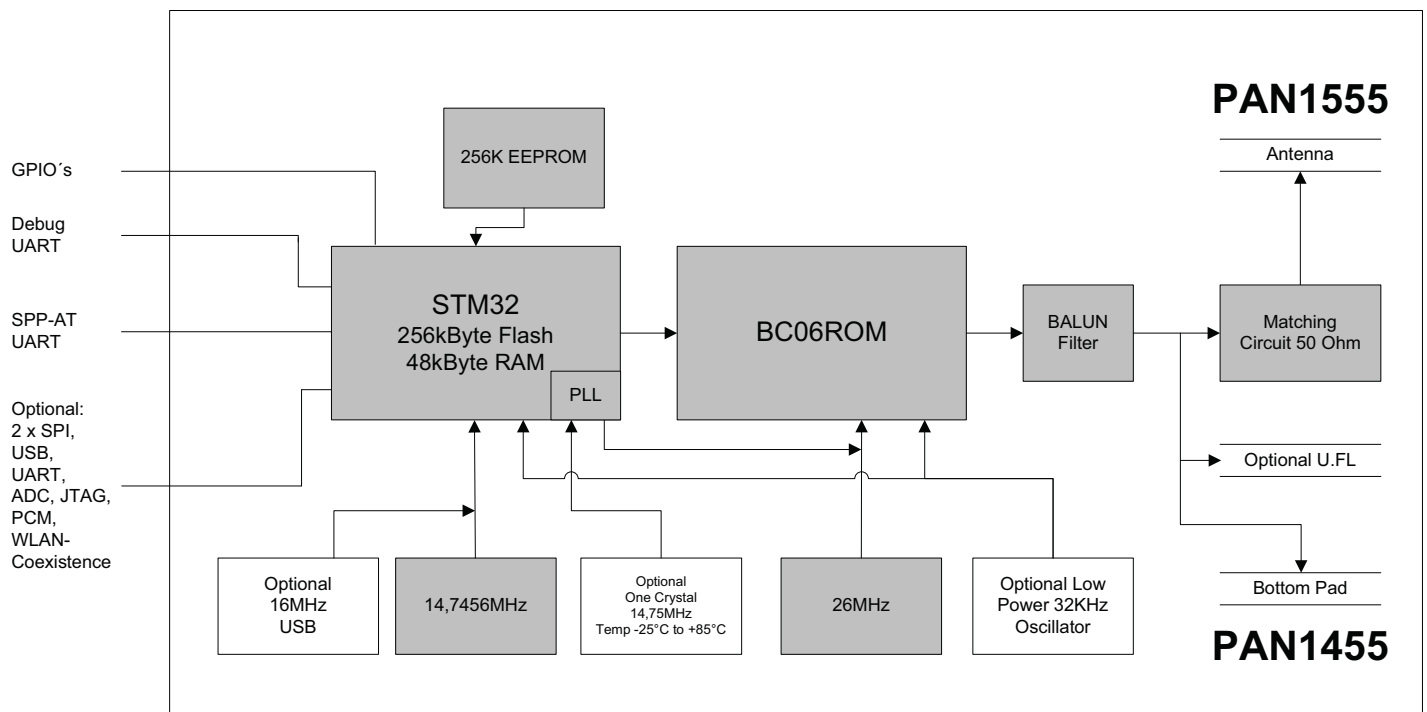

Technical Specifications:

Parameter	Value	Condition / Notes
Receiver Sensitivity (BER=10 ⁻³)	-86 dBm typ.	ideal wanted signal
Output Power	+4 dBm typ.	
Power Supply	2.7 - 3.6 V	Single operation voltage
Ultra Low Power Mode	< 100 μ A	T = 25°C
ACL (connected DH5)	50.5 mA to 49.5 mA	max power to min power *
ACL (connected DH1)	48.0 mA to 46.0 mA	max power to min power *
Operating Temperature Range	-40°C to + 85°C	Storage up to +125°C

* Figure indicates to the shortest poll period and to the slave mode

Panasonic

Electronic Components

Panasonic Industrial Company's Electronic Components Division is one of the industry's largest suppliers of standard and custom electronic components. Our wide product offering, coupled with our global manufacturing and sales capabilities, as well as our commitment to customer service make us a preferred vendor to the world's most famous original equipment manufacturers of high-tech electronic products.

- Capacitors
- Resistors
- Electromechanical
- Wireless Modules
- Inductive Products
- High Frequency Components
- Light Touch Switches
- Film Capacitors
- Filters & Resonators
- Electrolytic Capacitors
- Circuit & Thermal Protection
- Ceramic Capacitors

Panasonic offers it all! Choosing Panasonic means more than selecting a name you know and trust, it means choosing the best quality components the industry can offer.

Panasonic Electronic Components

3 Panasonic Way
Secaucus, NJ 07094
1-800-344-2112

www.panasonic.com/industrial/components/

Also available from Panasonic Industrial...

Batteries	Semiconductors	Appliance Parts & Motors	Computer Components
			
www.panasonic.com/industrial/battery/	www.panasonic.com/industrial/semi/	www.panasonic.com/industrial/appliance/	www.panasonic.com/industrial/computer/

Panasonic ideas for life