

# Instant Internet Evaluation Board II-EVB-600



## User Manual

Version 1.1



**International:**  
Connect One Ltd.  
20 Atir Yeda Street  
Kfar Saba 44643, Israel  
Tel: +972-9-766-0456  
Fax: +972-9-766-0461  
E-mail:  
[sales@connectone.com](mailto:sales@connectone.com)  
<http://www.connectone.com>

**USA:**  
Connect One  
Semiconductors, Inc.  
560 S. Winchester Blvd.  
Suite 500  
San Jose, CA 95128  
Tel: (408) 572-5675  
Fax: (408) 572-5601

## **Program License Agreement**

The information in this document is subject to change without notice and shall not be construed as a commitment on the part of Connect One.

Connect One assumes no liability for any errors that may appear in this document.

The software described in this document is furnished under a license agreement and may be used or copied only in accordance with the terms of such a license agreement. It is forbidden by law to copy the software on any medium except as specifically allowed in the license agreement. No part of this document may be reproduced or transmitted in any form or by any means, electronic or mechanical, including but not limited to photocopying, recording, transmitting via fax and/or modem devices, scanning, and/or information storage and retrieval systems for any purpose without the express written consent of Connect One.

iChip, AT+i, and Connect One are trademarks of Connect One Ltd.

Copyright © 2000–2008 Connect One Ltd. All rights reserved.

## Warranty Statement

Connect One warrants to the Customer that the Products to be delivered hereunder will function in accordance with the specifications published with regard thereto by Connect One, under conditions of normal use and service and when used in accordance with Connect One's instructions, for a period of 12 (twelve) months from shipment by Connect One or its distributor to the customer. Connect One will, at its option, repair or replace Products that fail to perform as aforesaid. The Customer will ship defective Products to be repaired or replaced to Connect One under warranty at Connect One's expense, and Connect One will, at its expense, ship the repaired Products or its replacement to the Customer.

In no event will Connect One's liability under the foregoing warranty exceed the purchase price of the defective Products.

The warranty set forth above will not apply (i) with respect to defects or damage caused by the use of unauthorized parts, the making of unauthorized repairs or improper use or maintenance, (ii) if service or repairs of the allegedly defective Products have been performed by persons other than qualified persons who have been properly trained to perform the same, (iii) if the allegedly defective Products have been affected by alterations, modifications or other tampering or misuse, (iv) if the allegedly defective Products have been removed from their original packaging prior to sale to the end-user or (v) if the allegedly defective Products have been used otherwise than in accordance with Connect One's instructions.

The provisions of the above sections set forth the Customer's sole and exclusive remedies with regard to Product failure. CONNECT ONE MAKES NO OTHER WARRANTIES, EXPRESSED OR IMPLIED, WITH RESPECT TO THE PRODUCTS, INCLUDING BUT NOT LIMITED TO ANY WARRANTY OF MERCHANTABILITY, FITNESS FOR A PARTICULAR PURPOSE, OR NON-INFRINGEMENT OF PATENT OR OTHER INTELLECTUAL PROPERTY RIGHTS. THERE ARE NO OTHER WARRANTIES WITH RESPECT TO THE PRODUCTS ARISING FROM ANY COURSE OF DEALING, USAGE OR TRADE OR OTHERWISE. IN NO EVENT WILL CONNECT ONE BE LIABLE FOR INDIRECT, SPECIAL OR CONSEQUENTIAL DAMAGES WHETHER UNDER THIS AGREEMENT, IN TORT OR OTHERWISE, OR FOR AN AMOUNT IN EXCESS OF THE ACTUAL AMOUNT PAID BY THE CUSTOMER TO CONNECT ONE FOR THE FAILED PRODUCTS.



**TABLE OF CONTENTS**

<b>PROGRAM LICENSE AGREEMENT .....</b>	<b>II</b>
<b>WARRANTY STATEMENT .....</b>	<b>III</b>
<b>1 PRODUCT OVERVIEW .....</b>	<b>1</b>
1.1 ICHIP 2064SEC: THE II-EVB-600 INTERNET ENGINE .....	1
1.2 HOW TO USE THIS MANUAL .....	1
<b>2 GETTING STARTED .....</b>	<b>2</b>
2.1 WHAT'S IN THE PACKAGE? .....	2
2.2 ADDITIONAL DOCUMENTATION .....	2
2.3 UNPACKING AND INSTALLING .....	2
2.4 CONNECTORS AND SWITCH POSITIONS .....	4
2.4.1 <i>Connectors</i> .....	4
2.4.2 <i>Switches</i> .....	5
2.5 LED POSITIONS .....	5
2.6 JUMPER SETTINGS .....	6
2.7 BILL OF MATERIALS .....	7
2.8 SCHEMATICS .....	14
2.9 RUNNING THE ICHIPCONFIG UTILITY FOR THE FIRST TIME .....	24
2.10 CONFIGURING FOR CONNECTION .....	25
2.10.1 <i>Dynamic IP Allocation</i> .....	26
2.10.2 <i>Fixed IP Configuration</i> .....	26
<b>3 FIRMWARE AND PARAMETERS UPDATE .....</b>	<b>28</b>
3.1 LOCAL FIRMWARE UPDATE .....	28
3.1.1 <i>Loading the Firmware from Host</i> .....	28
3.1.2 <i>Loading the Firmware from SPI Flash Memory</i> .....	28
3.2 MANAGING PARAMETER FILES .....	31
3.2.1 <i>Saving the II-EVB-600 Configuration to an RPF File</i> .....	32
3.2.2 <i>Loading an RPF File</i> .....	32

# 1 Product Overview

Connect One's II-EVB-600 with its iChip™ CO2064SEC IP-enables and offloads connectivity tasks from a host processor or host device. II-EVB-600 supports effortless integration of many upper layer Internet protocols using either AT+i commands or the iChipConfig Utility, both of which are discussed in this document.

II-EVB-600 features include the ability to stream data over TCP or UDP sockets (up to 10 simultaneous active sockets are available) and manage two listening sockets. In addition, a secure socket (SSL3/TLS1) is fully supported. Additional features include the ability to send plain-text e-mails; an FTP client, and the SerialNET (Device Server) mode, a plug-and-play operating mode that enables the connection of any device with an RS232 interface to the Internet, without changing anything on the device's hardware or software.

## 1.1 iChip 2064SEC: The II-EVB-600 Internet Engine

The host processor communicates with the II-EVB-600 via Connect One's high-level AT+i™ command set. AT+i commands are simple ASCII characters that are sent across the RS232 interface. The AT+i Application Programming Interface (API) requires writing just a few lines of code on the host processor to implement Internet connectivity.

AT+i commands make it very easy to configure, test, and implement high-level Internet protocols with virtually no understanding of TCP/IP or other Internet protocols. Thanks to the AT+i commands, the device only needs to tell the II-EVB-600 what task to perform, but not how to perform it. For example, if the device has to send textual e-mail, after a one-time short configuration of subject, recipient, mail account, etc., the device sends AT+iEOA:<lines of text>.

The iChip inside the II-EVB-600 establishes a connection or uses the existing one, builds the e-mail (headers and content), connects to the SMTP server, and sends the e-mail. A status report is sent to the device upon completion. All these actions are completely hidden from the device and only require sending a few characters in addition to the e-mail content. This mode of operation is applicable for all features of the II-EVB-600.

## 1.2 How to Use this Manual

iChipConfig Utility is a front-end Windows-based user interface for the AT+i commands. The iChipConfig Utility, combined with the II-EVB-600, enables quick and full product configuration, serial-based updating of firmware, and packaging of a parameters file. This functionality is achieved from any device, machine, or system.

**Note:** From this point onward, this manual assumes that you have the iChipConfig Utility installed. The configuration, running and testing of the II-EVB-600 is demonstrated via the iChipConfig Utility, although they can also be carried out using AT+i commands. For a complete description of the AT+i interface and commands, please refer to the AT+i Programmer's Manual on the Connect One website: <http://www.connectone.com>.

To set up the iChipConfig Utility, please refer to the *iChipConfig Utility User Manual Version 2.4.44* or higher.

The latest version of the iChipConfig Utility can be found on the Connect One website: <http://www.connectone.com>.

## 2 Getting Started

This section describes the content of the II-EVB-600 package, provides additional relevant documentation to enhance and fine-tune the II-EVB-600 functionality, and includes unpacking and first-time configuration instructions. The final section of this chapter offers several ways to test the II-EVB-600 LAN connection.

### 2.1 What's in the Package?

The II-EVB-600 is a turnkey boxed solution and, as such, is supplied with all necessary accessories. The package includes the following items:

- II-EVB-600 evaluation board
- RS232 cable
- RJ45 Cat 5 100BaseT cable
- 110V or 220V power supply
- Extra iChip CO2064SEC

### 2.2 Additional Documentation

The II-EVB-600 is built around the iChip CO2064SEC. Great flexibility in configuration and operation of this product can be achieved via proper use of the AT+i commands.

For the sake of simplicity, the II-EVB-600 configuration and operation is described in this document mainly through the iChipConfig Utility.

The iChipConfig Utility and the iChipConfig Utility User Manual can be downloaded from the Connect One website.

**Note:** Because documentation, utilities and firmware files change from time to time, please be sure to check for the latest version on the Connect One website: <http://www.connectone.com>.

### 2.3 Unpacking and Installing

The II-EVB-600 installation is simple and all the required accessories are supplied with the device.

The II-EVB-600 is provided pre-configured to work with LAN using COM1 on the II-EVB-600 as host interface. For additional configuration options, see section [2.5 Jumper Settings](#).

➤ **To install the II-EVB-600 and connect it to a LAN network:**

- 1 Connect the RJ45 cable to the II-EVB-600 RJ45 port. Connect the other end of the cable to a 10/100BaseT or 100BaseT Ethernet switch or hub.

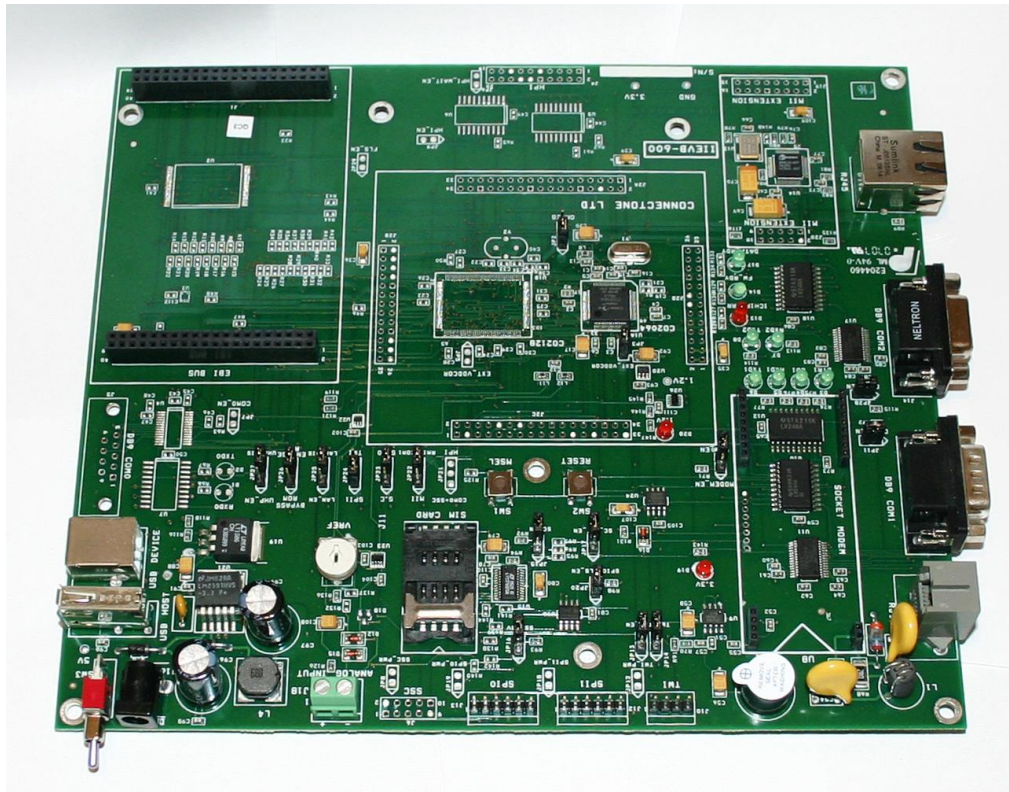

- 2 Connect one side of the RS232 cable to the II-EVB-600 RS232 COM1 port and the other side to your device or PC's COM port.
- 3 Connect the power supply to the DC jack on the II-EVB-600 and apply power.  
The Link LED (orange) on the RJ45 should now be on and the Activity LED (green) should blink occasionally, reflecting network traffic.

To test the connection, use AT+ commands or the iChip Config Utility to invoke any of the activities that trigger the iChip to go online and use the Internet or local LAN.



## 2.4 Connectors and Switch Positions

### 2.4.1 Connectors

	Name	Type	Function
1	J2A	HEADER 17X2	CO2128 EXTENSION
2	J2B	HEADER 13X2	CO2128 EXTENSION
3	J2C	HEADER 17X2	CO2128 EXTENSION
4	J2D	HEADER 13X2	CO2128 EXTENSION
5	J1	HEADER 20X2	EBI BUS (for CO2128)
6	J2	HEADER 20X2	EBI BUS (for CO2128)
7	J4	HEADER 10X2	HPI (for CO2128)
8	J5	DB9 – FEMALE	COM0 (for CO2128)
9	J6	HEADER 5X2	SSC (for CO2128)
10	J7	RJ11	Telephone Line (from Uart1)
11	J8	DB9 –MALE	COM1
12	J9	RJ45	10/100BaseT
13	J10	HEADER 4X1	TWI
14	J11	SIM CARD	SIM CARD
15	J12	HEADER 6X1	SPI1
13	J13	HEADER 6X1	SPI0
14	J14	DB9 – FEMALE	COM2
15	J15	USB-A	USB Host
16	J16	DC-JACK	POWER Supply
17	J17	USB-B	USB Device
18	J18	BLOCK 2 Pin	Analog Input
19	J19	HEADER 8X2	MII EXTENSION
20	J20	HEADER 5X2	MII EXTENSION

## 2.4.2 Switches

	Name	Type	Function
1	SW1	PUSH BOTTOM	MSEL
2	SW2	PUSH BOTTOM	RESET
3	SW3	TOGGLE SWITCH	POWER On/Off

## 2.5 LED Positions

	Name	Type	Function
1	D1	G.LED	RXD0
2	D2	G.LED	TXD0
3	D3	G.LED	DTR1
4	D4	G.LED	CD1
5	D5	G.LED	RXD1
6	D6	G.LED	TXD1
7	D7	G.LED	RXD2
8	D8	G.LED	TXD2
9	D9	R.LED	iChip Error
10	D13	G.LED	FW_RDY
11	D14	R.LED	3V VDDIO
12	D17	G.LED	DATA READY
13	D19	R.LED	5V For USB Host
14	D20	R.LED	1.2V

## 2.6 Jumper Settings

	Name	Setting
1	JP2	1-2 ONREG Pin=0 working with external VDD core ; 2-3 ONREG Pin=1 working with internal VDD core
2	JP3	ON –External VDDCore (For CO2064)
3	JP5	ON –External VDDCore (For CO2128)
4	JP6	ON- Enable 1K Pull-up Resistor On HPI_nWAIT signal. (HPI_Wait_Enable For CO2128)
5	JP7	ON- Enable COM0 (only when HPI is disable) (For CO2128)
6	JP8	ON – Power to J6 Connector (SSC) (For CO2128)
7	JP9	ON- Enable HPI (For CO2128)
8	JP10	ON- Enable Socket Modem (on Uart1)
9	JP11	ON- Enable COM1
10	JP12	ON – Power to J10 Connector (TWI)
11	JP13	ON- Enable 1K Pull-up Resistor On TWI_TWD signal.
12	JP14	ON- Enable 1K Pull-up Resistor On TWI_TWCK signal.
13	JP15	ON- Enable SIM CARD
14	JP16	ON- SIM Card 3V ; OFF SIM Card 5V
15	JP17	ON- Enable SIM Card Interrupt .
16	JP18	ON – Power to J12 Connector (SPI1)
17	JP19	ON – Power to J13 Connector (SPI0)
18	JP20	ON – Enable SPI1 Flash
19	JP21	1-2 = COM0+ssc ; 2-3 = HPI
20	JP22	1-2 = MII ; 2-3 = RMII+COM1
21	JP23	1-2 = S.C ; 2-3 = SPI0
22	JP24	1-2 = SPI1 ; 2-3 = TWI
23	JP25	1-2 = LAN_EN ; 2-3 = LAN_DIS;
24	JP26	1-2 = BYPASS Rom ;2-3 = ENGAGE Rom

25	JP27	1-2 = UHP_EN ; 2-3 = UHP_DIS
26	JP28	ON – COM2 Enable COM2_EN
27	JP29	ON – Enable Parallel Flash (For CO2128)

## 2.7 Bill of Materials

Part Description	Designation	Quantity
Electromagnetic Sound Transducer/RoHS	LS1	1
Capacitor 1nF/3KV, Size 7mm	C53-C54	2
Capacitor 1uF/16V, TANTALOM, Case A	C107	1
Capacitor 1uF/16V, TANTALOM, Case A	C80	1
Capacitor 1uF/16V, TANTALOM, Case A	C109	1
Capacitor 1uF/16V, TANTALOM, Case A	C35-C36	2
Capacitor 1uF/16V, TANTALOM, Case A	C39	1
Capacitor 10uF/16V,TANTALOM,Case B/RoHS	C88	1
Capacitor 10uF/16V,TANTALOM,Case B/RoHS	C108	1
Capacitor 10uF/16V,TANTALOM,Case B/RoHS	C42	1
Capacitor 10uF/16V,TANTALOM,Case B/RoHS	C56	1
Capacitor 10uF/16V,TANTALOM,Case B/RoHS	C58	1
Capacitor 10uF/16V,TANTALOM,Case B/RoHS	C20	1
Capacitor 10uF/16V,TANTALOM,Case B/RoHS	C79	1
Capacitor 10uF/16V,TANTALOM,Case B/RoHS	C113	1
Capacitor 10uF/16V,TANTALOM,Case B/RoHS	C92	1
Capacitor 15pF	C100-C101	2
Capacitor 22pF	C33-C34	2

Capacitor 47pF	C104	1
Capacitor 47pF	C94-C95	2
Capacitor 100nF, Size 0603	C71-C78	8
Capacitor 100nF, Size 0603	C81-C82	2
Capacitor 100nF, Size 0603	C86	1
Capacitor 100nF, Size 0603	C90-C91	2
Capacitor 100nF, Size 0603	C98-C99	2
Capacitor 100nF, Size 0603	C18	1
Capacitor 100nF, Size 0603	C110-C112	3
Capacitor 100nF, Size 0603	C22-C32	11
Capacitor 100nF, Size 0603	C37	1
Capacitor 100nF, Size 0603	C41	1
Capacitor 100nF, Size 0603	C43-C44	2
Capacitor 100nF, Size 0603	C49-C52	4
Capacitor 100nF, Size 0603	C55	1
Capacitor 100nF, Size 0603	C57	1
Capacitor 100nF, Size 0603	C59-C60	2
Capacitor 100nF, Size 0603	C102-C103	2
Capacitor 100nF, Size 0603	C65-C68	4
Capacitor 100nF, Size 0603	C105-C106	2
Capacitor 100uF/10V TANTALOM Case D	C69-C70	2
Capacitor 470nF	C93	1
Capacitor 470nF	C61-C64	4
Capacitor 470nF	C87	1
Capacitor 470nF	C45-C48	4

Capacitor 470nF	C83-C85	3
Capacitor 1000uF/25V Electrolytic/RoHS	C96-C97	2
iChipSec CO2128, 128pin LQFP, 3.3v, 48MHz, RoHS	U1B	1
D-Sub Right Angle, Female 9 pin Connector/RoHS	J5	1
D-Sub Right Angle, Female 9 pin Connector/RoHS	J14	1
D-Sub Right Angle, Male 9 pin Connector/RoHS	J8	1
Connector DC-JACK 2.1mm/RoHS	J16	1
ABS UL94-V0; 0.46m/m DIA	J7	1
RJ45 10/100BaseT Magnetics/RoHS	J9	1
CON SIM/SMA Holder/RoHS	J11	1
CONN TERMINAL BLOCK 2POS 5mm PCB/RoHS	J18	1
CONN USB FEMALE TYPE A PCB	J15	1
CONN USB FEMALE TYPE B PCB	J17	1
Crystal Clock 12 MHz/RoHS	Y2	1
1.0 AMP SILICON RECTIFIERS DIODE/RoHS	D10	1
DIA SURGE SUPPRESSOR (DSS)	RV1	1
FAST SWITCHING SURFACE MOUNT DIODE/RoHS	D15-D16	2
FAST SWITCHING SURFACE MOUNT DIODE/RoHS	D12	1
Ultrafast Rectifiers 1.0A ;50V-600V/RoHS	D11	1
Header 2mm Pitch SQ Tail Socket 2pin,Female/RoHS	U8A	1
HEADER 2x1 / MALE 100 MIL PITCH	J20	1
HEADER 2x1 / MALE 100 MIL PITCH	JP5-JP7	3
HEADER 2x1 / MALE 100 MIL PITCH	JP13-JP17	5
HEADER 2x1 / MALE 100 MIL PITCH	JP9-Jp11	3

HEADER 2x1 / MALE 100 MIL PITCH	JP28-JP29	2
HEADER 3x1 / MALE 100 MIL PITCH	JP2	1
HEADER 3x1 / MALE 100 MIL PITCH	JP21-JP27	7
Header 2mm Pitch SQ Tail Socket 4pin,Female/RoHS	U8D	1
HEADER 4x1 / MALE 100 MIL PITCH	J10	1
HEADER 5x2 / MALE 100 MIL PITCH	J20	1
HEADER 5x2 / MALE 100 MIL PITCH	J6	1
HEADER 6x1 / MALE 100 MIL PITCH	J12	2
HEADER 8x2 / MALE 100 MIL PITCH	J19	1
Header 2mm Pitch SQ Tail Socket 9pin,Female/RoHS	U8B-U8c	2
HEADER 10x2 /MALE 100 MIL PITCH	J4	1
HEADER 20x2/FEMALE100 MIL PITCH/RoHS	J1-J2	2
Low Power High Speed Rail to Rail Amp/RoHS	U23	1
Low Power High Speed Rail to Rail Amp/RoHS	U26	1
Low Voltage Audio Power Amplifier/RoHS	U9	1
SDPT Analog Switch/RoHS	U22	1
1A Step-Down Regulator;Out-3.3v/RoHS	U21	1
8 MBIT,Buttom-Boot 3v Flash/RoHS	U2	1
4Mbit 3.3V Serial Flash with SPI Interface/RoHS	U16	1
IC Buffer/Ldriver Octal/RoHS	U7	1
IC Buffer/Ldriver Octal/RoHS	U18	1
IC Buffer/Ldriver Octal/RoHS	U12	1
Octal Buffers/Drivers With 3-State Outputs	U10	1
Octal Buffers/Drivers With 3-State Outputs	U6	1

3V Octal Bidirectional Transceiver/RoHS	U5	1
IC SINGLE INVERTER GATE / RoHS	U3	1
10/100 PHY CONTROLLER/RoHS	U14	1
100mA Low-Drop Regulator 1.2v/RoHS	U20	1
Adjustable 1.5A LDO Voltage Regulator	U19	1
RS232, 3 Driver/5 Receiver 3v/5v,Ind/RoHS	U4	1
RS232, 3 Driver/5 Receiver 3v/5v,Ind/RoHS	U17	1
RS232, 3 Driver/5 Receiver 3v/5v,Ind/RoHS	U11	1
3v/3.3v Micro Supervisory Circuit, Ind/RoHS	U24	1
Smart Card Interface/RoHS	U15	1
Temp Sence/RoHS	U27	1
Indactor Unshiled 68uH 1.1A SMT/RoHS	L4	1
BK2125-102/RoHS	L2	1
BK2125-102/RoHS	L9-L12	4
Wound Beads,Turns:2x1.5; Wire:0.53 24 AWG/RoHS	L1	1
2mm Plastic Female Jumper 2pin/RoHS	JP2	1
2mm Plastic Female Jumper 2pin/RoHS	JP5-JP7	3
2mm Plastic Female Jumper 2pin/RoHS	JP13-Jp17	5
2mm Plastic Female Jumper 2pin/RoHS	JP9-JP11	3
2mm Plastic Female Jumper 2pin/RoHS	JP20-JP29	10
LED-GREEN 3mm	D17	1
LED-GREEN 3mm	D1-D8	8
LED-GREEN 3mm	D14	1
LED-RED 3mm	D13	1



LED-RED 3mm	D19-D20	2
Oscillator Clock 50MHz, SMD,Ind/RoHS	U13	1
POLYSWITCH RXE Series 0.30A Hold/RoHS	F1	1
Potentiometer 10K Ohm / RohS	P1	1
Resistor 0 Ohm 10%	R87	1
Resistor 0 Ohm 10%	R85	1
Resistor 0 Ohm 10%	R149	1
Resistor 0 Ohm 10%	R94	1
Resistor 0 Ohm 10%	R136	1
Resistor 0 Ohm 10%	R50	1
Resistor 2 Ohm 10%	R68-R69	2
Resistor 3K	R135	1
Resistor 3K	R106-R112	7
Resistor 3K	R117	1
Resistor 4.7K 10%	R131	1
Resistor 6.8K 1%	R86	1
Resistor 10 Ohm 10%	R70	1
Resistor 10K 1%	R65	1
Resistor 10K 1%	R90-R93	4
Resistor 10K 1%	R62	1
Resistor 10K 1%	R78-R80	3
Resistor 10K 1%	R145-R146	2
Resistor 15k	R122	1
Resistor 15k	R126	1
Resistor 15k	R120	1

Resistor 27 Ohm 10%	R119	1
Resistor 27 Ohm 10%	R121	1
Resistor 27 Ohm 10%	R123-R124	2
Resistor 33 Ohm 10%	R7-R48	42
Resistor 49.9 Ohm 1%	R81-R84	4
Resistor 100 Ohm 10%	R116	1
Resistor 100K 10%	R63	1
Resistor 100K 10%	R98	1
Resistor 100K 10%	R53-R61	9
Resistor 100K 10%	R71-R73	3
Resistor 100K 10%	R115	1
Resistor 100K 10%	R51	1
Resistor 300 Ohm 10%	R118	1
Resistor 470 Ohm 10%	R128	1
Resistor 470 Ohm 10%	R88-R89	2
Resistor 470 Ohm 10%	R130	1
Resistor 470 Ohm 10%	R134	1
Resistor 470 Ohm 10%	R143	1
Resistor 470 Ohm 10%	R66-R67	2
Resistor 470 Ohm 10%	R113-R114	2
Resistor 470 Ohm 10%	R147	1
Resistor 470 Ohm 10%	R74-R77	4
TOGEL SW ON/OFF-SPDT-90D/RoHS	SW3	1
SW-TACK/RoHS	SW1-SW2	2

## 2.8 Schematics



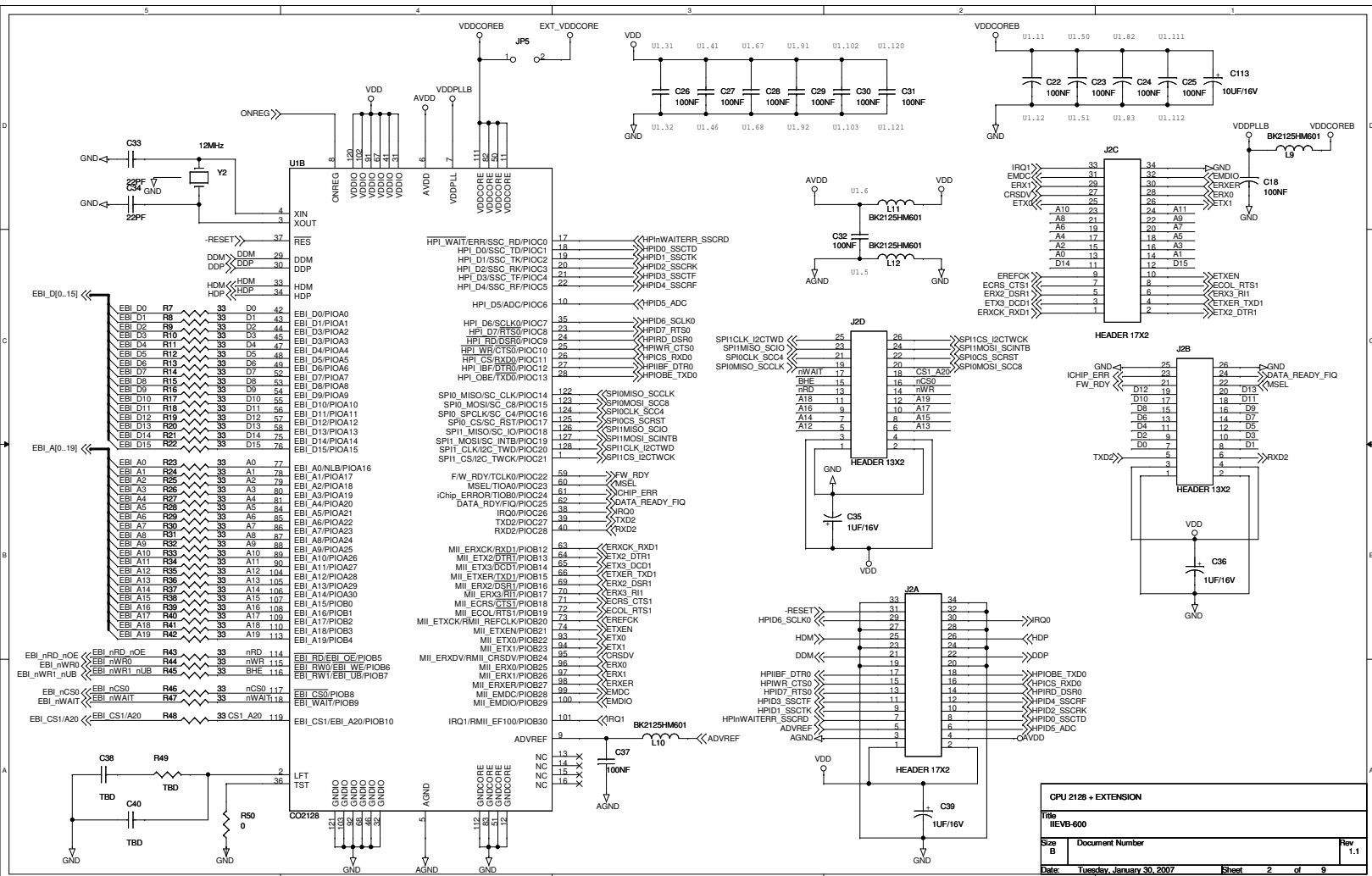

EBI\_D[0..15]  
EBI\_A[0..19]

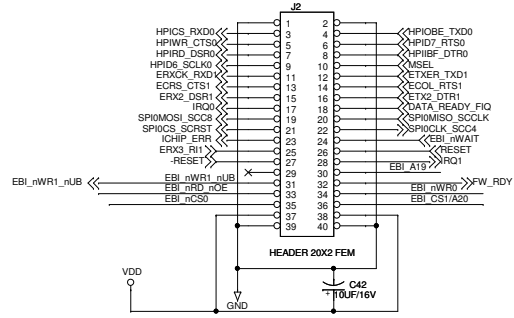
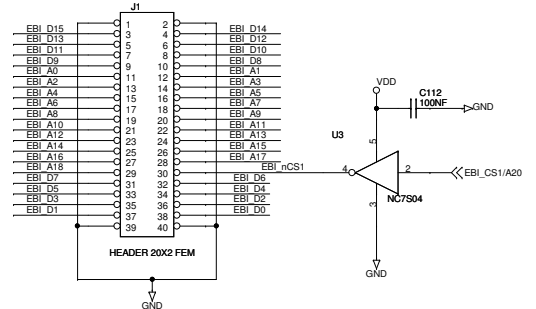
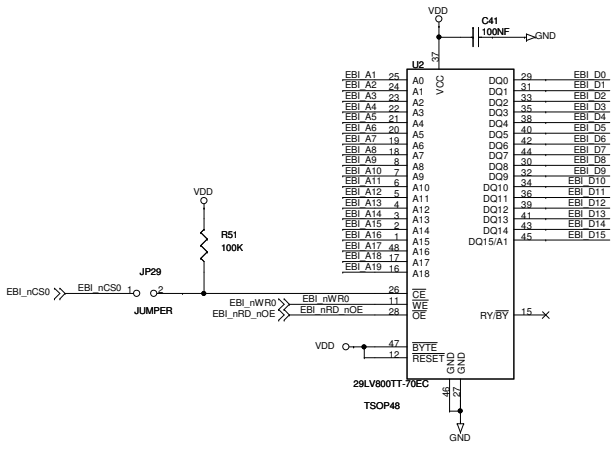

EBI BUS + PARALLEL FLASH (ONLY FOR CO2128)		
Title HEVB-600		
Size B	Document Number	Rev 1.1
Date: Tuesday, January 30, 2007	Sheet 3 of 9	

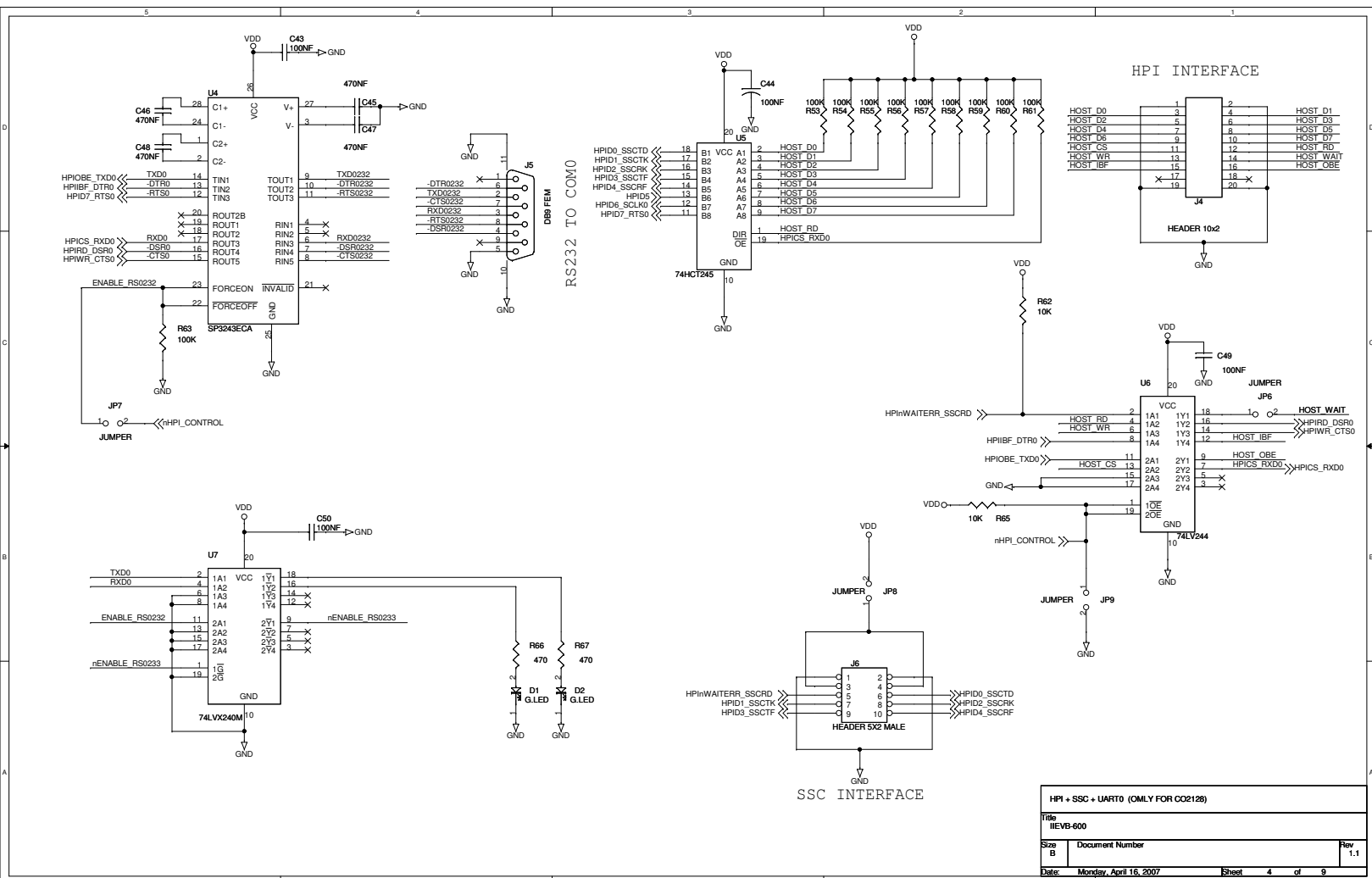

HPI + SSC + UART0 (ONLY FOR C02128)			
Title			
HEVB-600			
Size	Document Number	Rev	
B		1.1	
Date:	Monday, April 16, 2007	Sheet	4 of 9

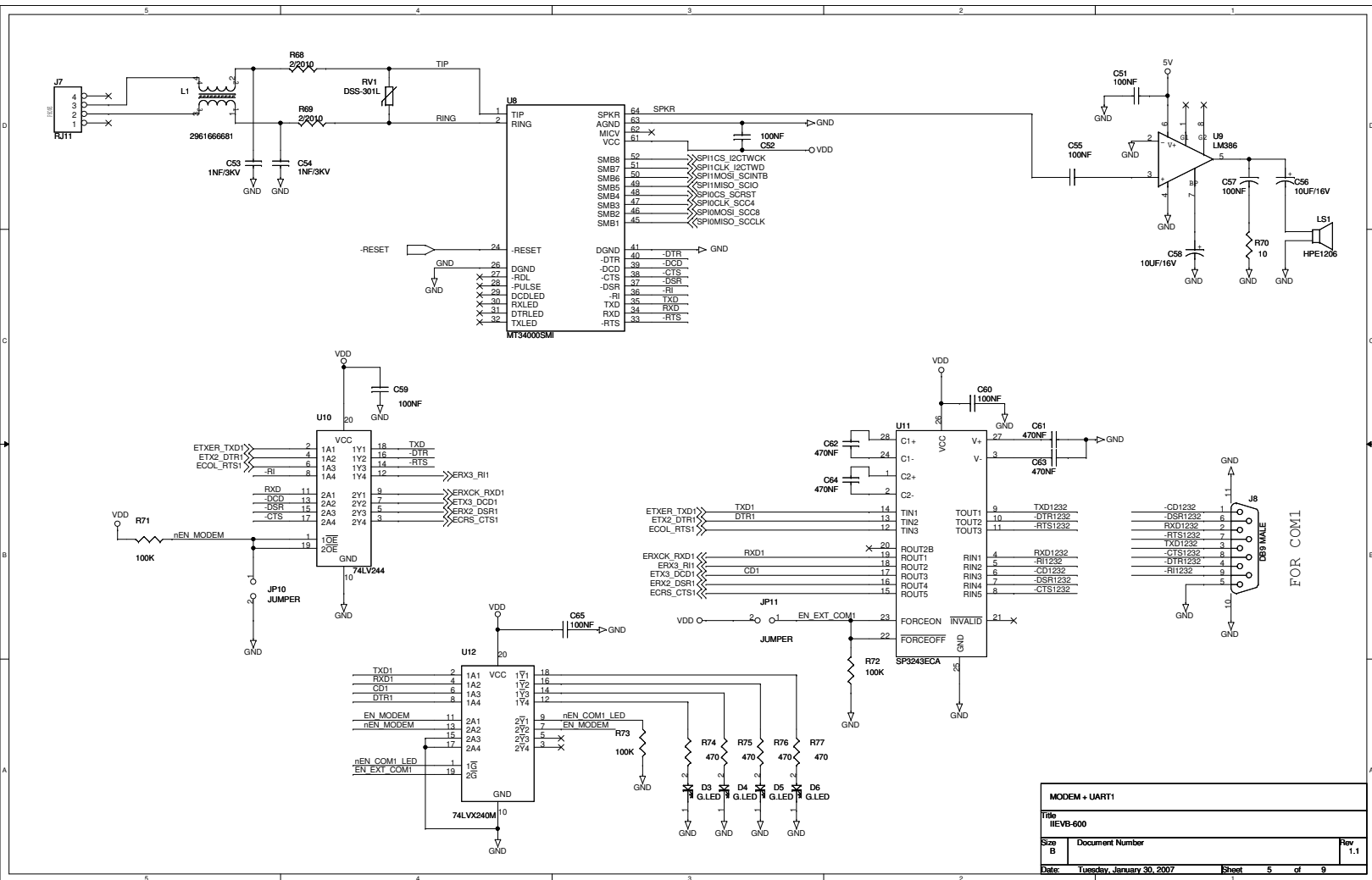



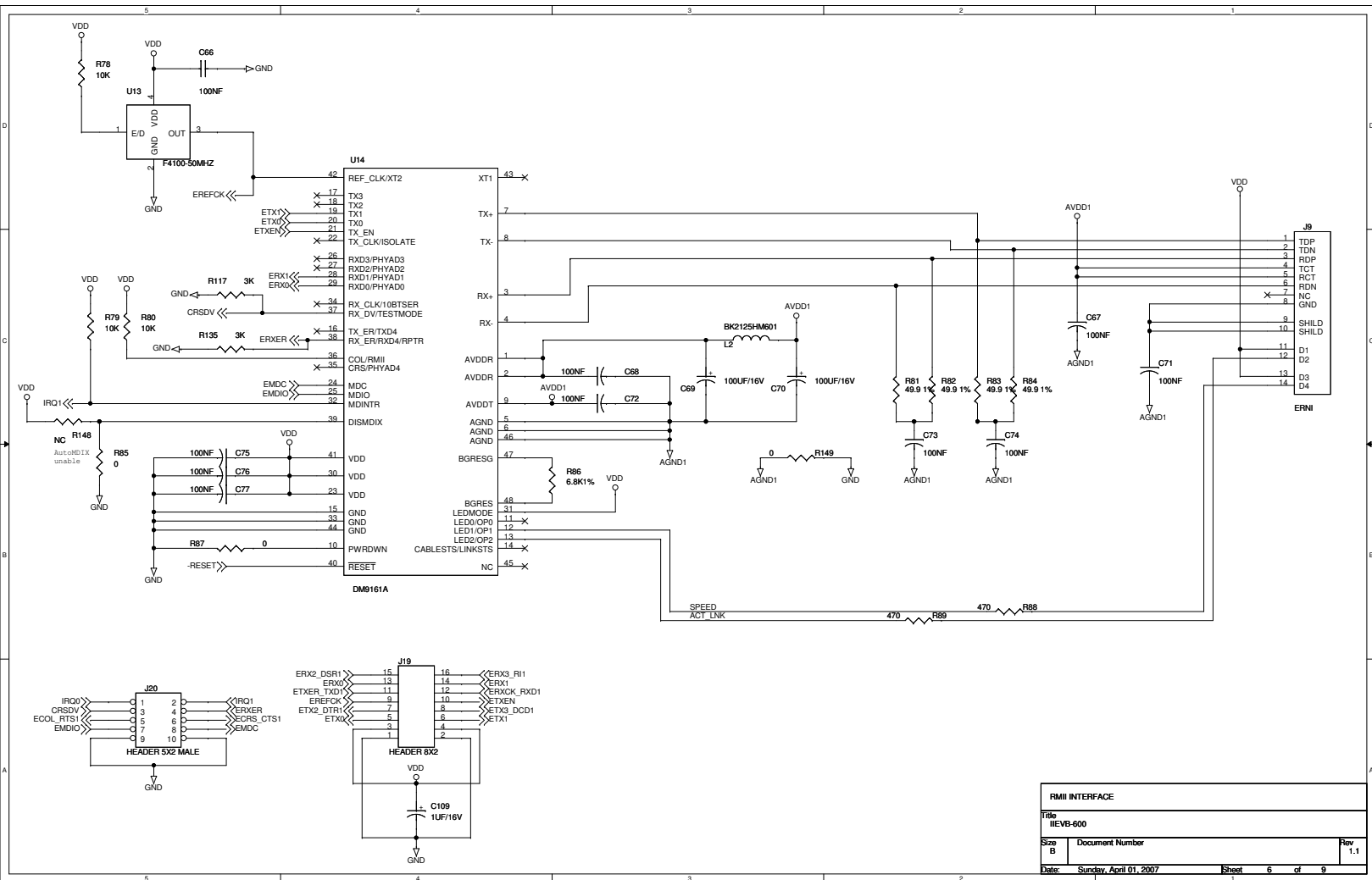

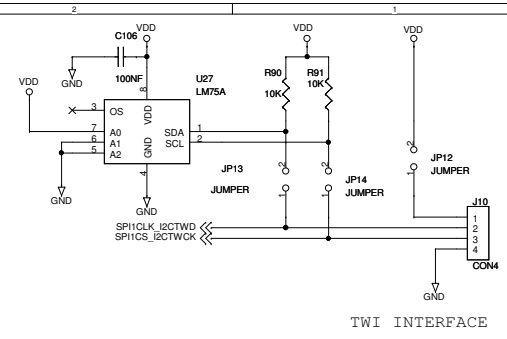
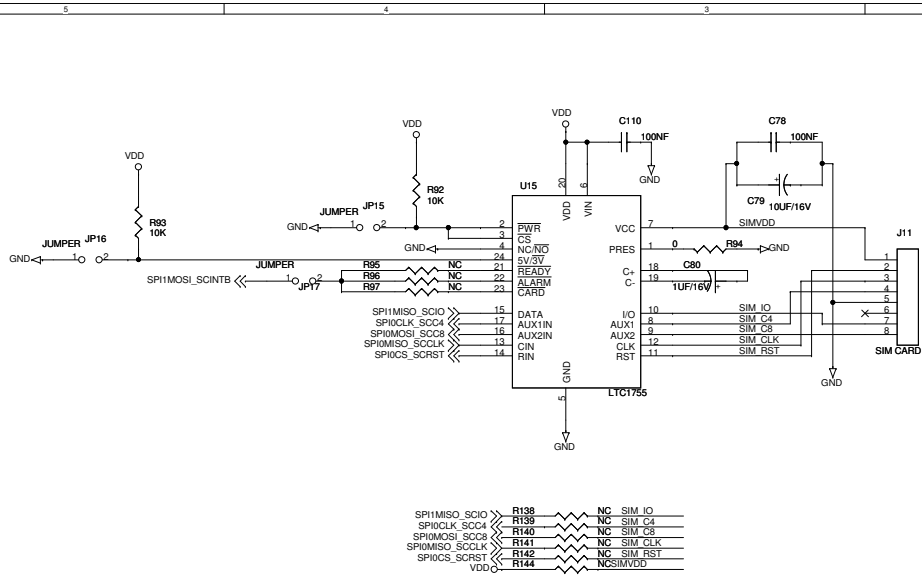

TWI INTERFACE

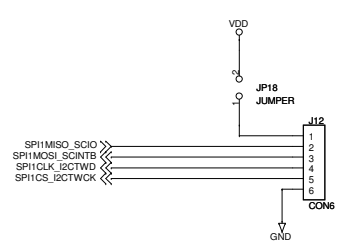

SPI1 INTERFACE

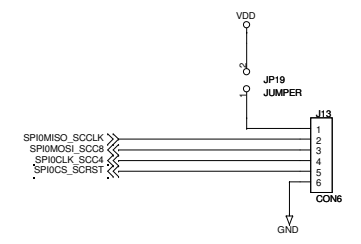
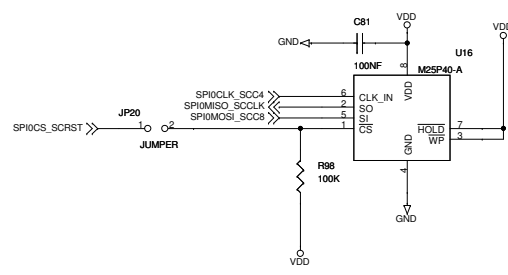

SPI0 INTERFACE

SPI0 FLASH + SPI1 + TWI + SIM INTERFACE		
Title: IIEVB-600		
Size: B	Document Number:	Rev: 1.1
Date: Wednesday, January 31, 2007	Sheet: 7	of: 9

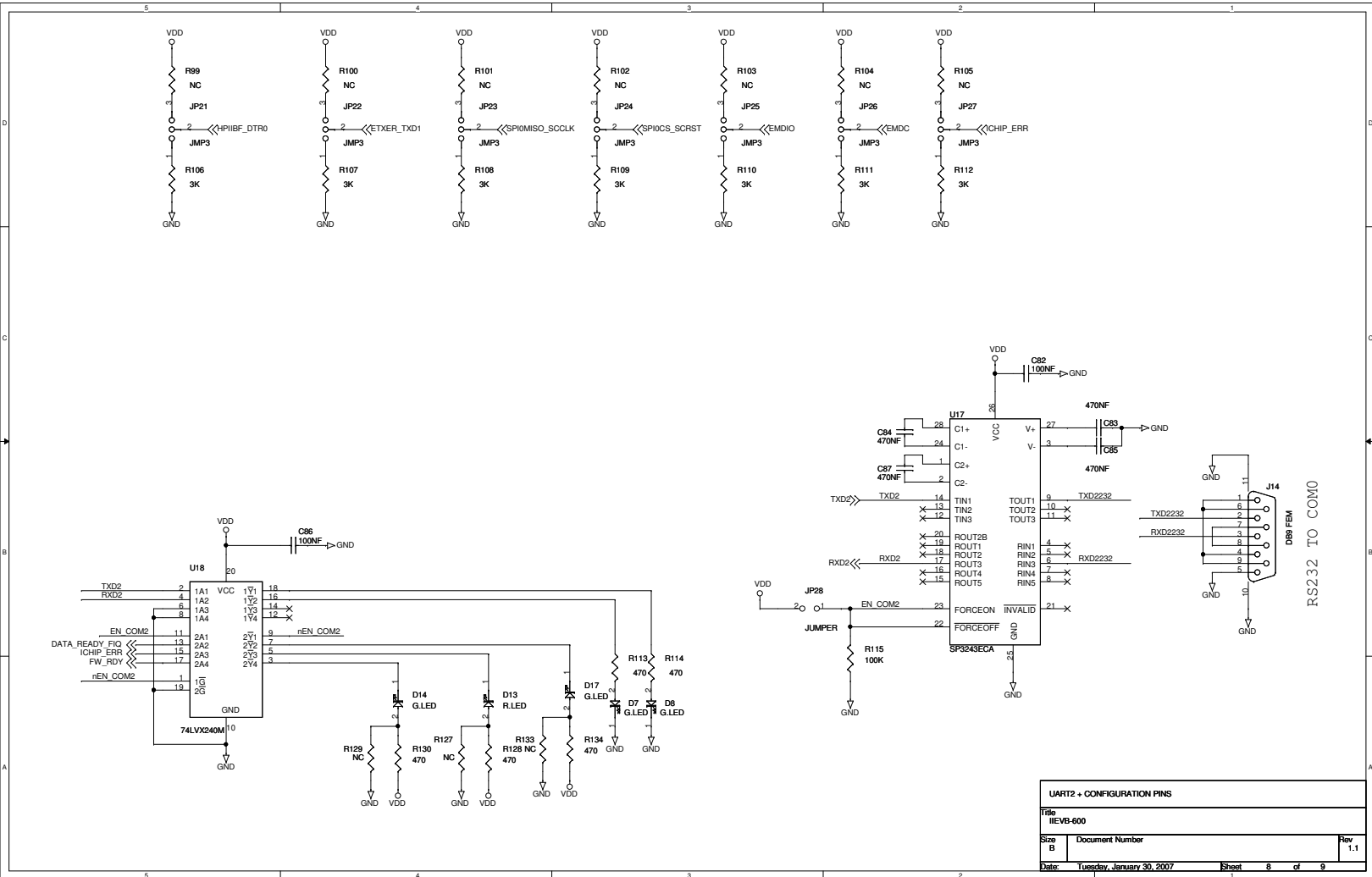

UART2 + CONFIGURATION PINS		
Title IIEVB-600		
Size B	Document Number	Rev 1.1
Date: Tuesday, January 30, 2007	Sheet 8	of 9

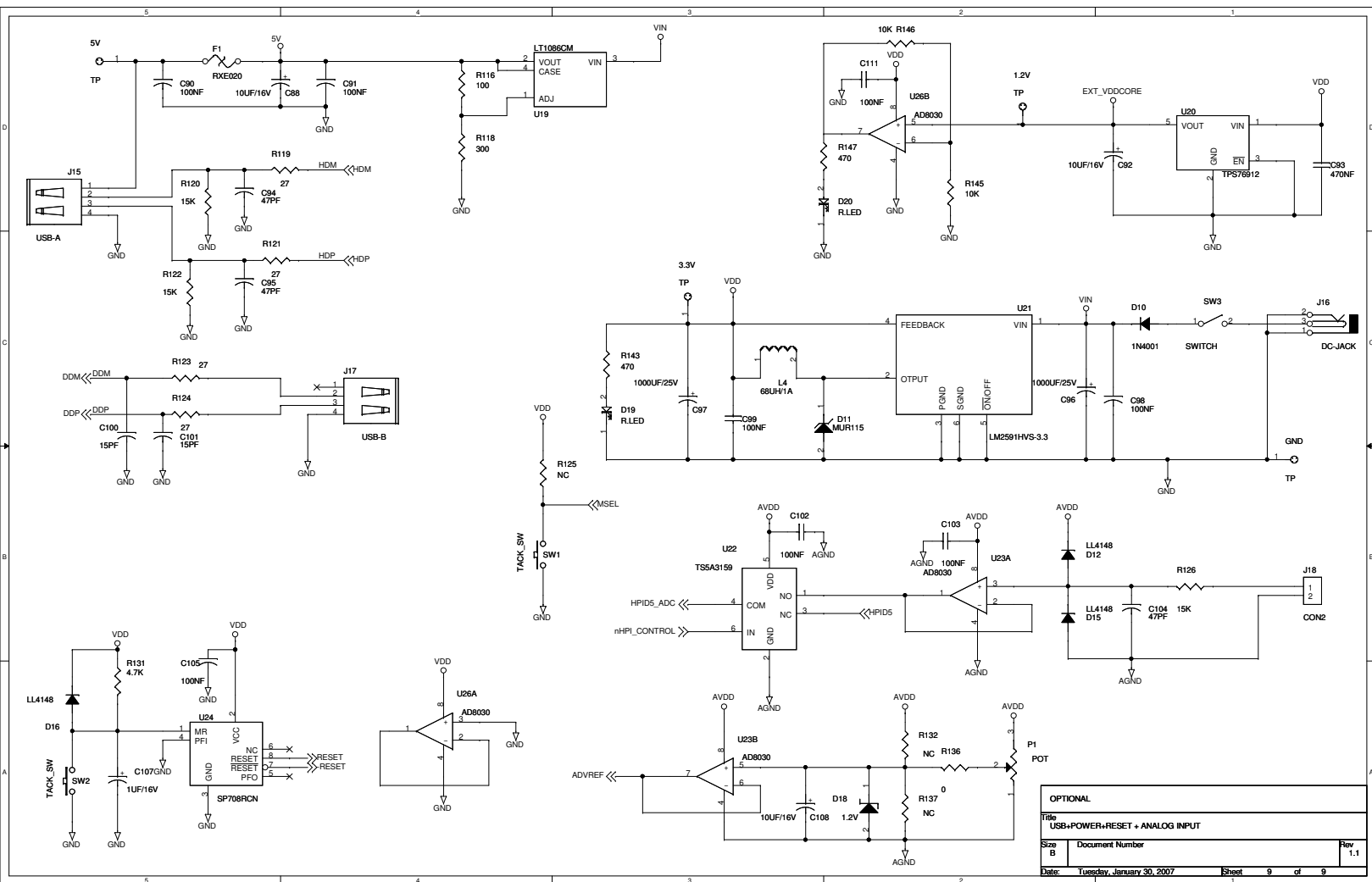

OPTIONAL		
Title	USB+POWER+RESET+ANALOG INPUT	
Size	Document Number	Rev
B		1.1
Date:	Tuesday, January 30, 2007	Sheet 9 of 9

## 2.9 Running the iChipConfig Utility for the First Time

This section describes how to start running the iChipConfig Utility.

### To start the iChipConfig Utility:

1. Select **Programs > ConnectOne > iChipConfig** from Windows **Start** menu. The *iChip Configuration Tools* window is displayed:

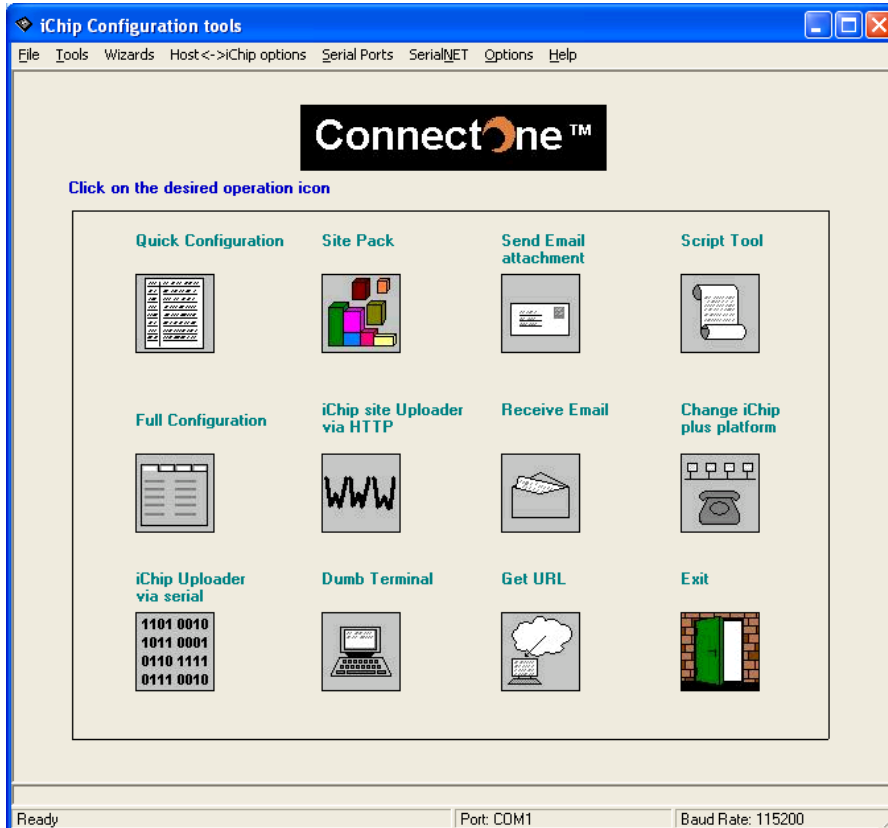

2. Select the desired operation by clicking the appropriate icon.

When an icon is selected (except **Exit**), the iChipConfig utility attempts to locate the II-EVB-600 on one of the PC's COM ports at the default baud rate of 38400.

If the II-EVB-600 is not located, the *Serial Settings* dialog box is displayed:

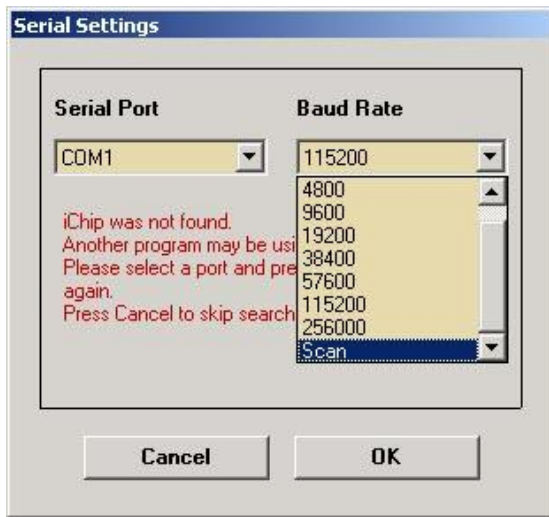

This dialog box is also displayed if you select **Serial Ports** from the menu bar.

3. From the **Serial Port** drop-down list, select the port to which the II-EVB-600 is attached.
4. In the *Baud Rate* area:
  - Select the exact **Baud Rate** used by the II-EVB-600.
  - or-
  - Select **Scan** if you don't know the baud rate.

If **Scan** is selected, iChipConfig Utility runs through the different baud rates until the correct baud rate to be used is found. The following message is displayed:



**Note:** If iChipConfig Utility still fails to find the II-EVB-600, make sure that there are no applications open, such as Palm HotSync, occupying the port; switch to a different COM port and try **Scan** again. After iChipConfig has found the baud rate, you can easily change it by opening the **Serial Settings** dialog box and selecting the desired baud rate.

## 2.10 Configuring for Connection

To be part of the LAN, the II-EVB-600 needs basic LAN settings, such as IP Address, Subnet and Gateway IP address. There are two ways to configure this set of parameters for II-EVB-600:

- Dynamic IP Allocation (Via DHCP)
- Fixed IP Configuration (Via User Assignment)

## 2.10.1 Dynamic IP Allocation

By default, the II-EVB-600 is configured to gain LAN access via DHCP. Therefore, if a DHCP server is present, there is no need for additional configuration.

Specific configuration for acquiring LAN settings via DHCP can be carried out from the *Quick Configuration* window in the figure below:

1. Select the **Use DHCP** check box and click **Save**.
2. To activate these settings, recycle power to the II-EVB-600.

**Note:** II-EVB-600 supports DHCP Server extensions. This means that if your server's assignees' have additional LAN settings, such as SMTP server, the II-EVB-600 automatically configures and uses these settings.

## 2.10.2 Fixed IP Configuration

To configure the II-EVB-600 to work with a fixed IP address, the following parameters should be configured:

1. Use the *Quick Configuration* screen to set the following parameters:

- **IP Address (DIP):** Set it to the IP address you want the II-EVB-600 to have.
  - **Subnet (SNET)**
  - **IP Gateway (IPG)**
2. Click **Save** and recycle power to the II-EVB-600.

These settings can also be configured using the following AT+i commands:

- AT+iDIP
- AT+iSNET
- AT+iIPG

A detailed description of these commands can be found in the *AT+i Programmer's Manual*.



## 3 Firmware and Parameters Update

This section describes the II-EVB-600 local firmware and parameters update capabilities using the iChipConfig utility.

It also describes how to create and use parameter files (\*.RPF).

### 3.1 Local Firmware Update

The II-EVB-600 can be updated locally in one of two ways. You can upload the firmware directly from the host (PC, in our case) via the RS232 interface, or from the external flash memory provided on the II-EVB-600 via the SPI interface.

#### 3.1.1 Loading the Firmware from Host

To load the iChip firmware from host memory via the RS232 serial interface, you need to obtain the RAM version of the firmware flavor you wish to install from Connect One. The RAM version is provided as two separate files: a *version.hdr* file and a *version.dat* file. The following procedure assumes that you have a host application running on your PC, in which you insert appropriate lines of code, as detailed below.

1. Power up the II-EVB-600 and assert the MSEL pin for *at least* 5 seconds.
2. Use the connected UART at a baud rate between 9600 and 115200 to send a capital  $\sigma$  character to the iChip. Wait for a  $>$  prompt.
3. Send a capital  $\tau$  and wait for a  $>$  prompt.
4. Send the *version.hdr* file and wait for a  $>$  prompt.
5. Send the *version.dat* file.
6. The firmware is now loaded into iChip's RAM and ready for use.

#### 3.1.2 Loading the Firmware from SPI Flash Memory

1. Invoke the iChipConfig utility.

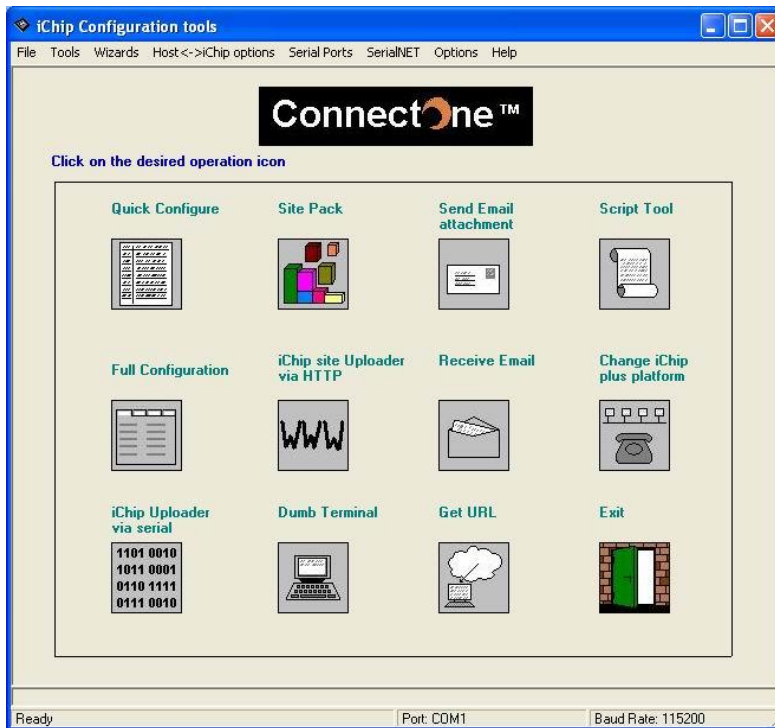

2. Click Tools > CO2128/2064 Monitor Mode.
3. In the dialog box displayed, select the SPI Flash 4 Mbit check box and click OK.

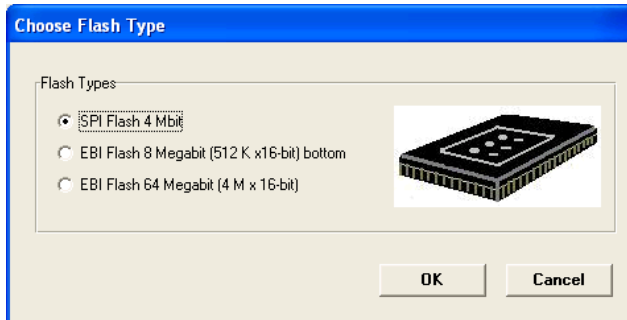

4. Wait for the utility to finish loading FPRO into iChip's RAM.

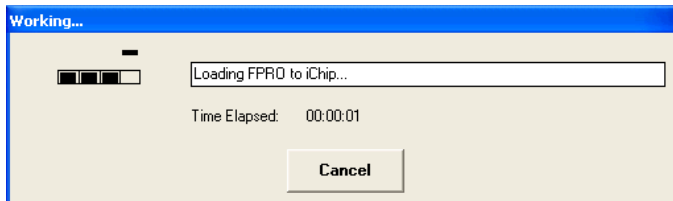

5. Power up the II-EVB-600 while holding down the MSEL switch for *at least* 5 seconds and OK the dialog box.

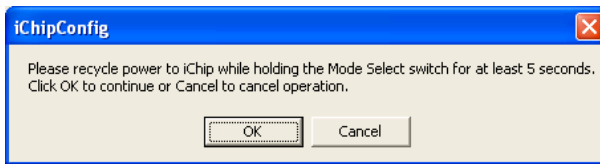

6. In the dialog box displayed, click the FW Update button.

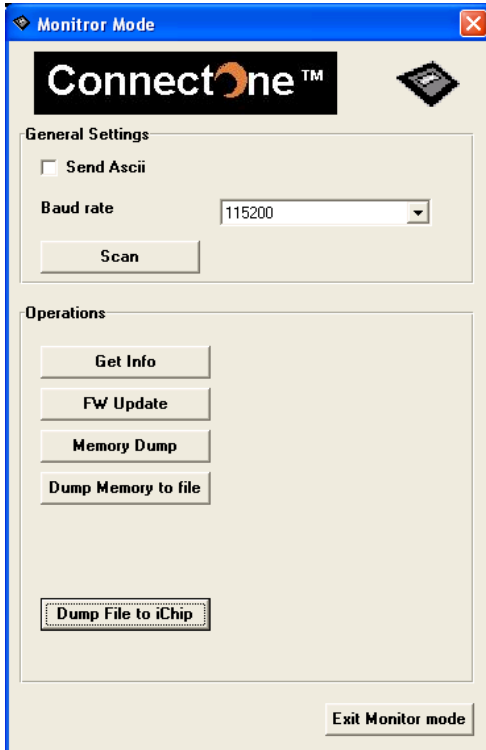

7. In the dialog box that appears, select the .imf image file of the firmware you wish to upload and click Open.

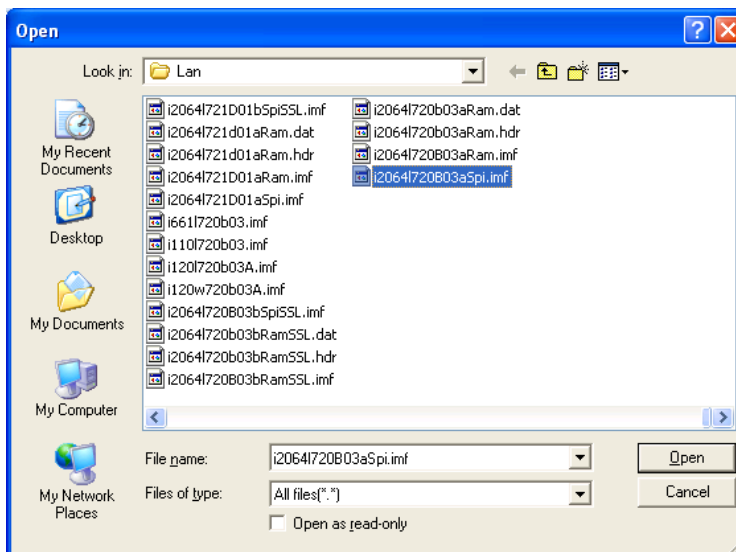

8. Click Yes when prompted.

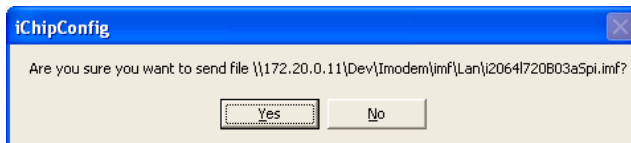

9. The following screen appears:

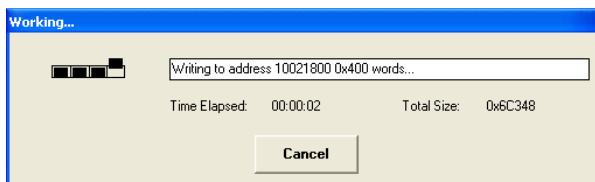

10. Click OK on the *Image file loaded successfully* dialog box.

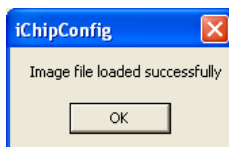

The firmware is loaded into the SPI flash memory. When you reset the iChip, it automatically loads the firmware from flash memory into its internal RAM.

## 3.2 Managing Parameter Files

Parameters for the II-EVB-600 are stored in **\*.RPF** files. Parameter files can be used to save current configurations to be loaded for later use or to automate product distribution.

### 3.2.1 Saving the II-EVB-600 Configuration to an RPF File

The parameters stored in the II-EVB-600 can be saved to a Remote Parameter File (RPF) or loaded from an RPF file onto the II-EVB-600.

#### To save the current configuration to an RPF file:

1. Click the **Full Configuration** icon. The II-EVB-600 *Full Configuration* window is displayed.
2. Click **File > Save as RPF File** in the *Full Configuration* window. The *RPF Parameters* dialog box is displayed:

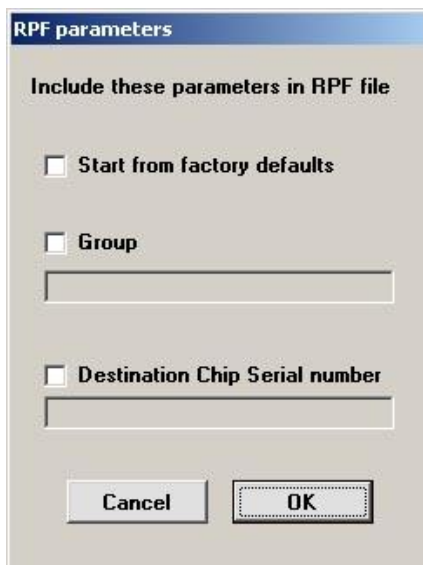

3. Configure the following parameters and click OK:
  - Select the **Start from factory defaults** check box if you want to save the factory default settings as your new parameters.
  - Do not select the **Start from factory defaults** check box if you want to save your current configuration (except for parameters) in the RPF file.
  - **Group** - Not relevant
  - **Destination Chip Serial Number** - Not relevant

### 3.2.2 Loading an RPF File

To load an RPF file onto the iChip:

1. Select **File > Load RPF file** from the **iChipConfig** menu. The *Open* dialog box is displayed:



2. Browse to the appropriate RPF file and click Open. All the parameters from the RPF file are loaded onto the II-EVB-600.
3. If an illegal parameter value has been assigned, iChipConfig Utility displays the illegal parameter and offers to save it to a log file. Enter a new valid parameter value and **Load/Save** the RPF file again.