

FEATURES/BENEFITS

- Latest generation MOSFET technology
- Ultra low on-state resistance
- Innovative isolated driver ensures fast power transistor turn on and off and thus low power transient
- Ultra low output leakage current
- Low control current consumption
- Triggered control input to avoid linear control risks
- Low conducted and radiated disturbances



Part Number	Description
S20DC30	30A, 200 Vdc Solid-State Relay

Part Number Explanation

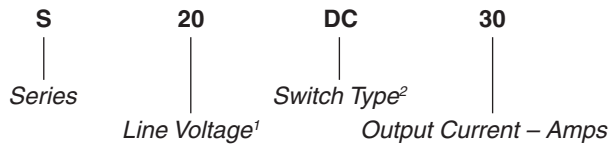

NOTES

- 1) Line Voltage (peak): 20 = 200 Vdc
- 2) Switch Type: DC = DC

ELECTRICAL SPECIFICATIONS

(+25°C ambient temperature unless otherwise specified)

INPUT (CONTROL) SPECIFICATIONS

	Min	Max	Units
Control Range	4.5	32	Vdc
Input Current Range	25	42	mAdc
Typical Turn-On Voltage	4.3		Vdc
Must Turn-Off Voltage	1		Vdc
Reverse Voltage		32	Vdc
Reverse Leakage Current		100	µA

CONTROL CHARACTERISTIC

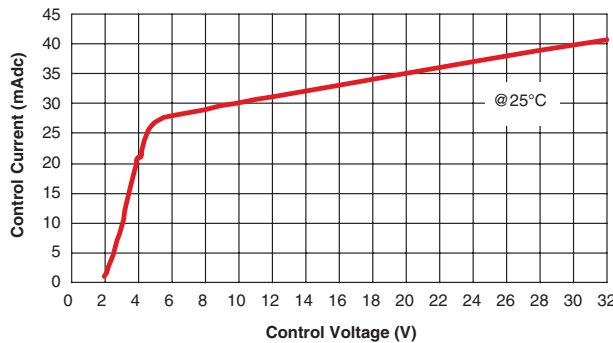
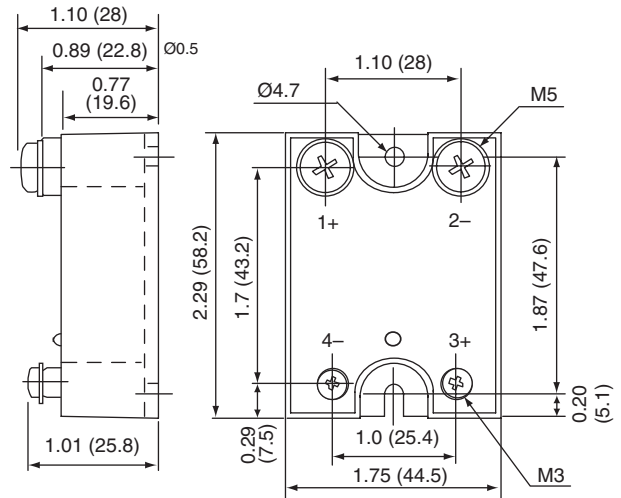

Figure 2

MECHANICAL SPECIFICATION



Tolerances: Ø0.3
Dimensions in inches (mm)
Weight: 3.52 oz. (100g)

Figure 1

BLOCK DIAGRAM

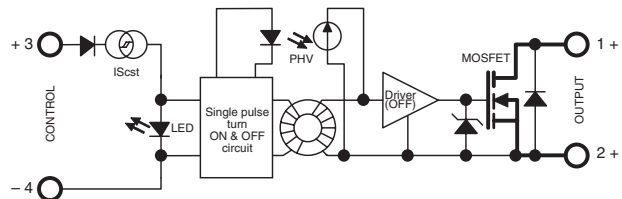

Figure 3

ELECTRICAL SPECIFICATIONS

(+25°C ambient temperature unless otherwise specified)

OUTPUT (LOAD) SPECIFICATIONS

	Min	Max	Units
Operating Range	0	130	Vdc
Peak Voltage		200	V _{peak}
Reverse Voltage (Internal Diode)	1.5		V
Maximum Repetitive Avalanche Current	30		A
Maximum Single Pulse Avalanche Energy		315	mJ
Maximum Repetitive Pulse Avalanche Energy		20	mJ
Maximum Nominal Currents (Resistive)	30		A
Non-Repetitive Peak Overload Current	120		A
Leakage Current	100		μA _{dc}
On-State Resistance		164	mΩ
Output Capacitance (Typical)	3.0		nF
Junction-Case Thermal Resistance	0.75		°C/W
Built-In Heat Sink Thermal Resistance (Vertically Mounted)	8		°C/W
Heat Sink Thermal Time Constant	10		min
Control Inputs/Power Outputs			
Insulation Voltage	4		kV
Turn-On Time		10	μs
Turn-On Delay		600	μs
Turn-Off Time		10	μs
Turn-Off Delay		100	μs
On-Off Frequency		700	Hz

TIME DIAGRAMS

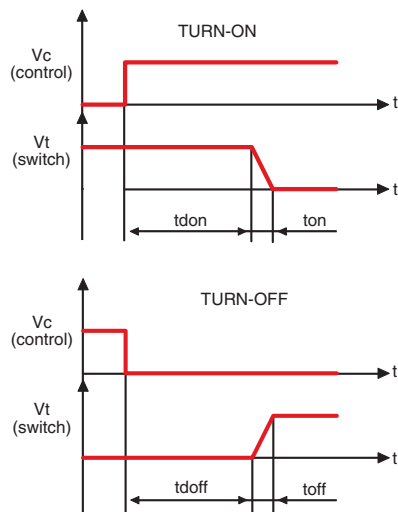

Figure 6

HIGH SIDE WIRING DIAGRAM
(Load Connected to “-”)

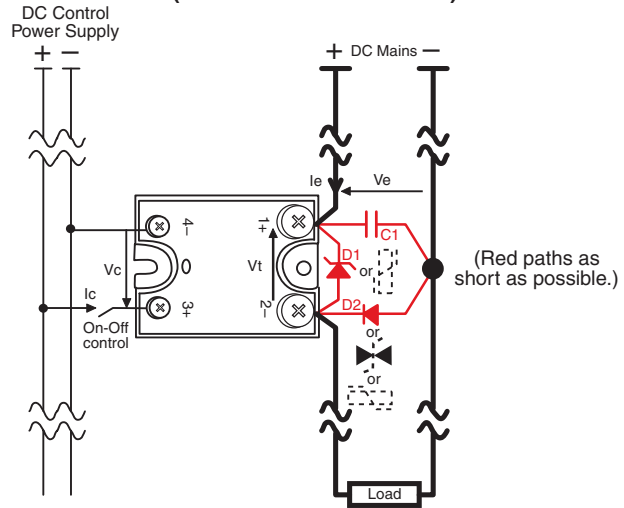

Figure 4

LOW SIDE WIRING DIAGRAM
(Load Connected to “+”)

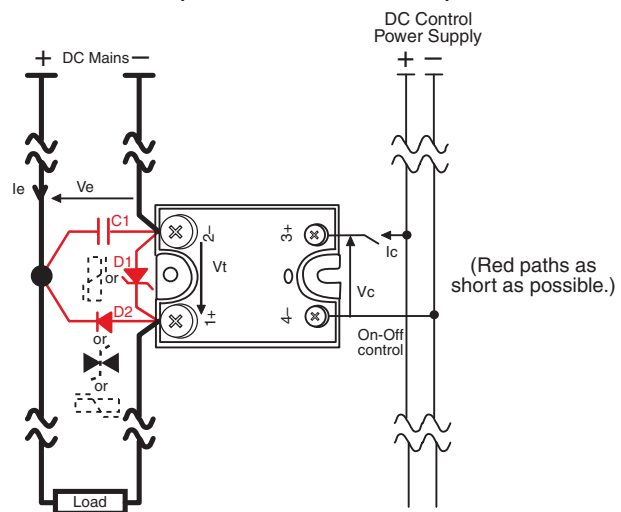

Figure 5

ON RESISTANCE VS. TEMPERATURE

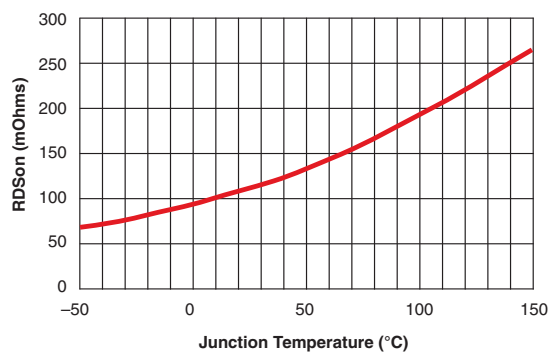

Figure 7

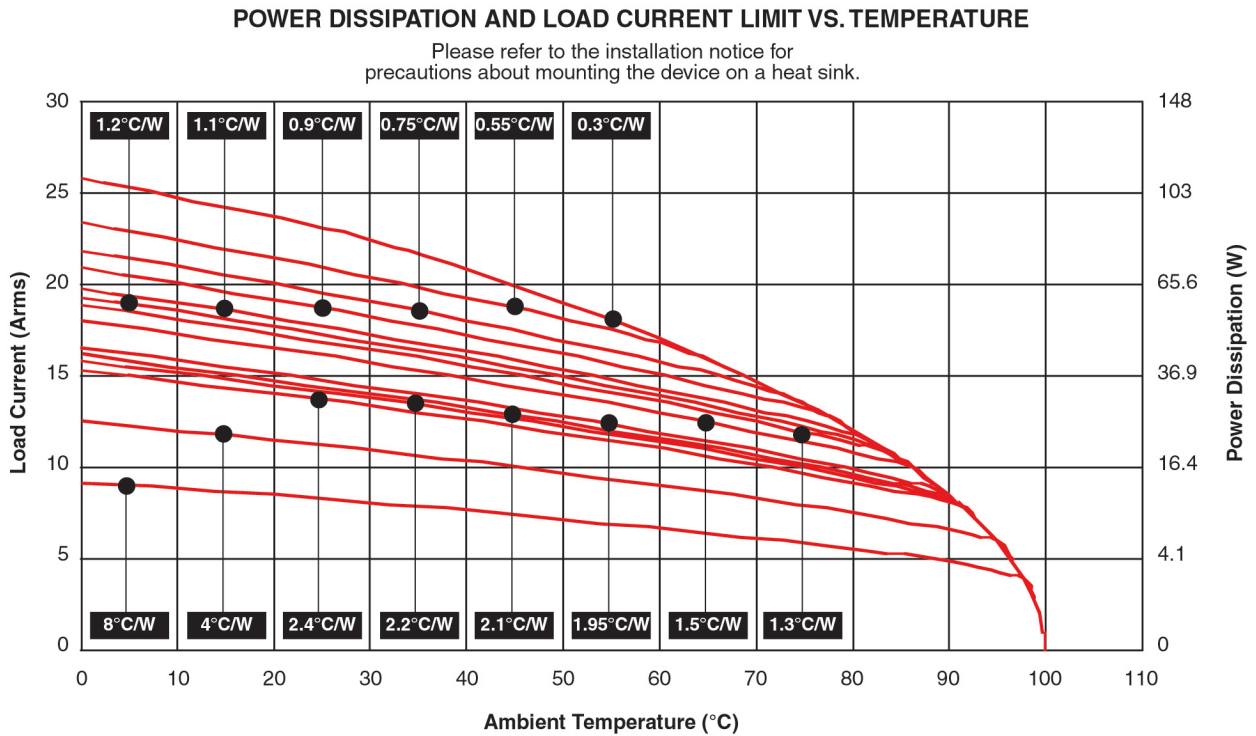

Figure 8

GENERAL SPECIFICATIONS

(+25°C ambient temperature unless otherwise specified)

ENVIRONMENTAL SPECIFICATIONS

	Min	Max	Units
Operating Temperature	-40	+90	°C
Storage Temperature	-40	+100	°C
Input-Output Isolation	4000		Vrms
Insulation Resistance	1		GΩ
Insulation Capacitance	8		pF
Junction Temperature		150	°C

CONNECTIONS

	Power	Control
Screwdriver	Phillips NR2	Phillips NR1
Tightening Torque	1.8 N.m	0.8 N.m
Insulated crimp terminals (Round Tabs, Eyelet Type)	M5	M3

MISCELLANEOUS

Display	Green LED (ON)
Housing	UL94V0
Mounting	2 screws (M4x12mm)
Noise Level	No audible noise

GENERAL

Standards	IEC60947-1
Protection Level	IP00
Protection Against Direct Touch	None
CE Marking	Yes

E.M.C. EMISSION

Radiated & Conducted Disturbances NFEN55011

PROTECTIVE COVER AVAILABLE

Add -14 to part number

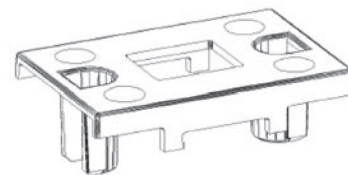

Figure 9

NOTES

1. For additional/custom options, contact factory.