

Part Number	Description
C3P24D25	25A, 280 Vac
C3P24D25C	25A, 280 Vac

Part Number Explanation

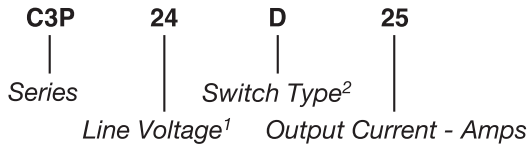

NOTES

- 1) Line Voltage (nominal): 48 = 480 Vac
- 2) Switch Type: D = Zero-cross turn-on
- 3) Thermal Pad: -12 (ex: C3P24D25C-12)

MECHANICAL SPECIFICATION

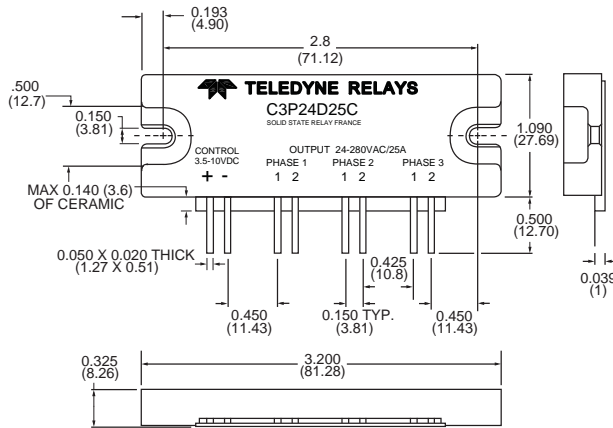

WEIGHT: 1.093 oz. (31g)

Figure 1 — Dimensions in inches [mm]

INPUT (CONTROL) SPECIFICATION

	Min	Max	Units
Control Range			
C3P24D25	10	30	Vdc
C3P24D25C	3.5	10	Vdc
Input Current Range	9	30	mA
Must Turn-Off Voltage		1	Vdc
Input Internal Resistor (Typical)		250	Ω
Input Resistance	(See Figure 2)		
Reverse Voltage Protection			
C3P24D25		30	Vdc
C3P24D25C		10	Vdc



FEATURES/BENEFITS

- Three-phase solid state relay in a compact SIP package
- High-temperature plastic housing for mechanical ruggedness
- Tight zero-cross window for low EMI
- Exposed ceramic baseplate for reduced thermal resistance

DESCRIPTION

The Series C3P three-phase AC solid-state relays are designed to control medium amounts of power in three-phase applications. Optical isolation ensures complete protection of the C3P's control circuit from load transients. The C3P's compact plastic housing provides a low-cost alternative to large metallic three-phase contactors. The C3P is designed with heatsinking in mind. The ceramic baseplate provides excellent thermal performance. The relay's tight zero-cross window greatly reduces EMI.

APPLICATIONS

- Heating control
- HVAC controls
- Light/Lamp control
- Three-phase AC loads

CONTROL CHARACTERISTIC

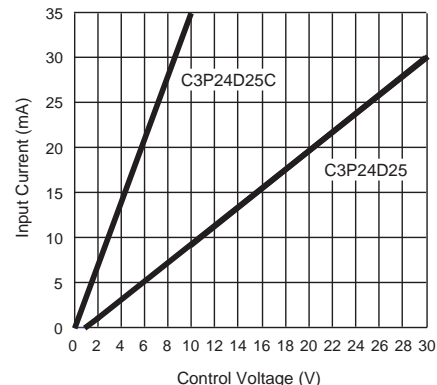

Figure 2

OUTPUT (LOAD) SPECIFICATION

	Min	Max	Units
Operating Range	24	280	Vrms
Peak Voltage		600	Vpeak
Load Current Range (See Figure 4)	.05	25	Arms
Maximum Surge Current Rating (Non-Repetitive) (See Figure 5)		250	A
On-State Voltage Drop	$0.81 + (0.018 \times I)$		V
Zero-Cross Window (Typical)		±12	V
Off-State Leakage Current (60 Hz)		1	mA
Turn-On Time		8.3	ms
Turn-Off Time		8.3	ms
Off-State dv/dt		500	V/μs
Operating Frequency Range	47	2000(*)	Hz
I ² t for Match Fusing (<8.3 ms)		260	A ² S
Thermal Resistance (One phase) R _{thj/c}		0.85	°C/W

ENVIRONMENTAL SPECIFICATION

	Min	Max	Units
Operating Temperature	-40	100	°C
Storage Temperature	-55	100	°C
Input-Output Isolation	2500		Vi
Output-Case Isolation	2500		Vi
Rated Impulse Voltage	2500		V

BLOCK DIAGRAM

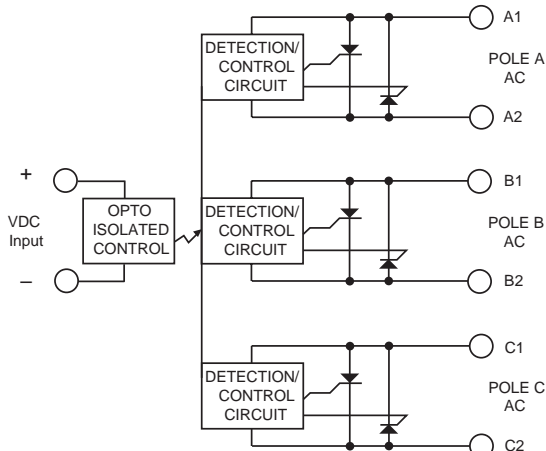

Figure 3

NOTES

1. Electrical specifications at 25 °C unless otherwise specified.
2. See figure 6 for output protection recommendation
3. For additional/custom options, contact factory

THERMAL CHARACTERISTICS

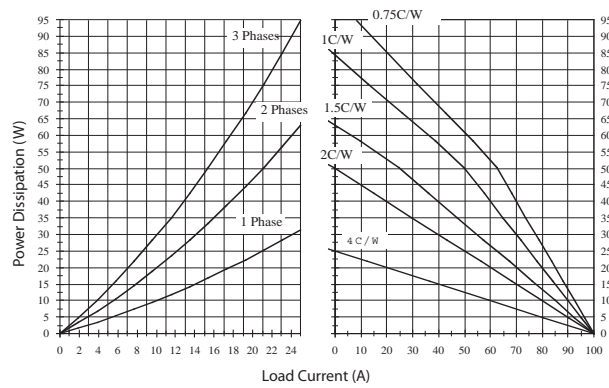

Figure 4

SURGE CURRENT

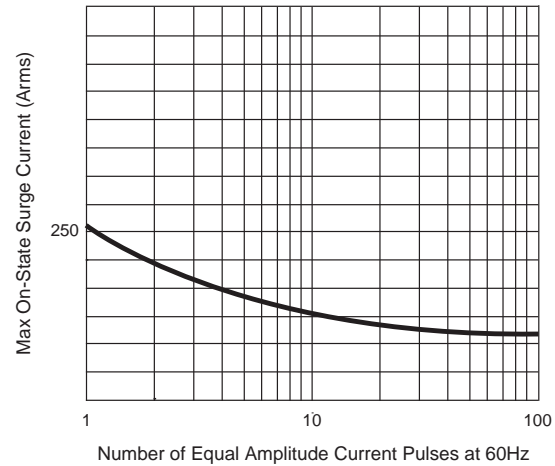

Figure 5

RECOMMENDED OUTPUT VOLTAGE PROTECTION

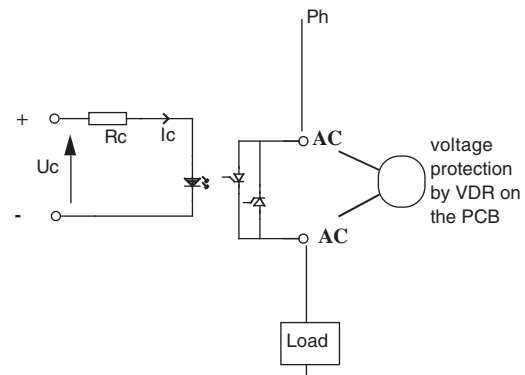

Figure 6

An external Voltage Dependent Resistor (VDR) is recommended in case of voltage spike.

NOTES

- (*) Relay built with back-to-back thyristors and high performance optocouplers. Relays have been tested at Teledyne Relays with frequencies higher than 2000 Hz on a resistive load. For other loads the user will have to check functionality in final application.