

High Speed Optocoupler, Single and Dual, 10 MBd

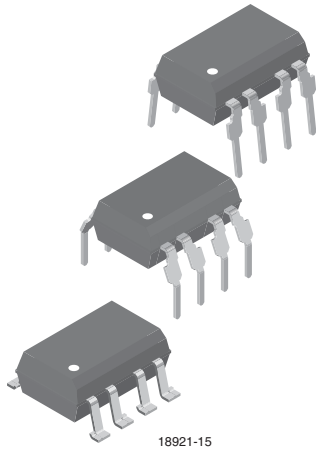

18921-15

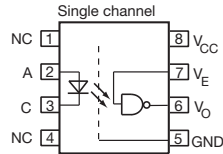

6N137, VO2601, VO2611

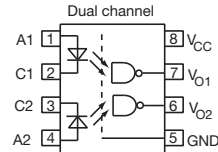

18921-30 VO2630, VO2631, VO4661



FEATURES

- Choice of CMR performance of 15 kV/μs, 5 kV/μs, and 100 V/μs
- High speed: 10 MBd typical
- + 5 V CMOS compatibility
- Pure tin leads
- Guaranteed AC and DC performance over temperature: - 40 °C to + 100 °C temperature range
- Meets IEC 60068-2-42 (SO₂) and IEC 60068-2-43 (H₂S) requirements
- Low input current capability: 5 mA
- Compliant to RoHS Directive to 2002/95/EC and in accordance WEEE 2002/96/EC



RoHS COMPLIANT

APPLICATIONS

- Microprocessor system interface
- PLC, ATE input/output isolation
- Computer peripheral interface
- Digital fieldbus isolation: CC-link, DeviceNet, profibus, SDS
- High speed A/D and D/A conversion
- AC plasma display panel level shifting
- Multiplexed data transmission
- Digital control power supply
- Ground loop elimination

AGENCY APPROVALS

- UL1577, file no. E52744 system code H, double protection
- cUL - file no. E52744, equivalent to CSA bulletin 5A
- DIN EN 60747-5-5 (VDE 0884) available with option 1
- BSI IEC 60950

DESCRIPTION

The 6N137, VO2601, and VO2611 are single channel 10 MBd optocouplers utilizing a high efficient input LED coupled with an integrated optical photodiode IC detector. The detector has an open drain NMOS-transistor output, providing less leakage compared to an open collector Schottky clamped transistor output. The VO2630, VO2631, and VO4661 are dual channel 10 MBd optocouplers. For the single channel type, an enable function on pin 7 allows the detector to be strobed. The internal shield provides a guaranteed common mode transient immunity of 5 kV/μs for the VO2601 and VO2631 and 15 kV/μs for the VO2611 and VO4661. The use of a 0.1 μF bypass capacitor connected between pin 5 and 8 is recommended.

ORDERING INFORMATION

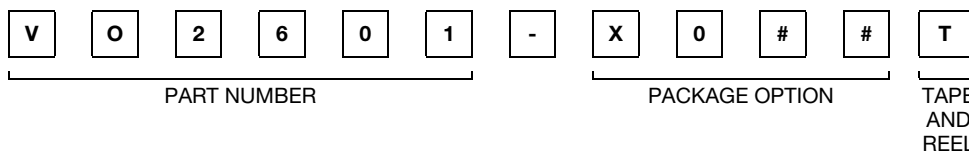

AGENCY CERTIFIED/PACKAGE	CHANNELS 1			CHANNELS 2		
	CMR (kV/μs)			CMR (kV/μs)		
BSI, UL, cUL	0.1	5	15	0.1	5	15
DIP-8	6N137	VO2601	VO2611	VO2630	VO2631	VO4661
DIP-8, 400 mil, option 6	6N137-X006	VO2601-X006	VO2611-X006	VO2630-X006	VO2631-X006	VO4661-X006
SMD-8, option 7	6N137-X007T	VO2601-X007T	VO2611-X007T	VO2630-X007T	VO2631-X007T	VO4661-X007T
VDE, BSI, UL, cUL	0.1	5	15	0.1	5	15
DIP-8, 400 mil, option 6	-	VO2601-X016	VO2611-X016	-	-	-
SMD-8, option 7	-	VO2601-X017T	VO2611-X017T	-	VO2631-X017T	-

6N137, VO2601, VO2611, VO2630, VO2631, VO4661



Vishay Semiconductors High Speed Optocoupler, Single and Dual,
10 MBd

TRUTH TABLE (positive logic)		
LED	ENABLE	OUTPUT
On	H	L
Off	H	H
On	L	H
Off	L	H
On	NC	L
Off	NC	H

ABSOLUTE MAXIMUM RATINGS ⁽¹⁾ (T _{amb} = 25 °C, unless otherwise specified)				
PARAMETER	TEST CONDITION	SYMBOL	VALUE	UNIT
INPUT				
Average forward current (single channel)		I _F	20	mA
Average forward current (per channel for dual channel)		I _F	15	mA
Reverse input voltage		V _R	5	V
Enable input voltage		V _E	V _{CC} + 0.5 V	V
Enable input current		I _E	5	mA
Surge current	t = 100 μs	I _{FSM}	200	mA
Output power dissipation (single channel)		P _{diss}	35	mW
Output power dissipation (per channel for dual channel)		P _{diss}	25	mW
OUTPUT				
Supply voltage	1 min maximum	V _{CC}	7	V
Output current		I _O	50	mA
Output voltage		V _O	7	V
Output power dissipation (single channel)		P _{diss}	85	mW
Output power dissipation (per channel for dual channel)		P _{diss}	60	mW
COUPLER				
Isolation test voltage	t = 1 s	V _{ISO}	5300	V _{RMS}
Storage temperature		T _{stg}	- 55 to + 150	°C
Operating temperature		T _{amb}	- 40 to + 100	°C
Lead solder temperature	for 10 s		260	°C
Solder reflow temperature ⁽¹⁾			260	°C

Notes

- Stresses in excess of the absolute maximum ratings can cause permanent damage to the device. Functional operation of the device is not implied at these or any other conditions in excess of those given in the operational sections of this document. Exposure to absolute maximum ratings for extended periods of the time can adversely affect reliability.

⁽¹⁾ Refer to reflow profile for soldering conditions for surface mounted devices (SMD). Refer to wave profile for soldering conditions for through hole devices (DIP).

RECOMMENDED OPERATING CONDITIONS					
PARAMETER	TEST CONDITION	SYMBOL	MIN.	MAX.	UNIT
Operating temperature		T _{amb}	- 40	100	°C
Supply voltage		V _{CC}	4.5	5.5	V
Input current low level		I _{FL}	0	250	μA
Input current high level		I _{FH}	5	15	mA
Logic high enable voltage		V _{EH}	2	V _{CC}	V
Logic low enable voltage		V _{EL}	0	0.8	V
Output pull up resistor		R _L	330	4K	Ω
Fanout	R _L = 1 kΩ	N		5	-



6N137, VO2601, VO2611, VO2630, VO2631, VO4661

High Speed Optocoupler, Single and Dual, Vishay Semiconductors
10 MBd

ELECTRICAL CHARACTERISTICS (T _{amb} = 25 °C, unless otherwise specified)						
PARAMETER	TEST CONDITION	SYMBOL	MIN.	TYP.	MAX.	UNIT
INPUT						
Input forward voltage	I _F = 10 mA	V _F	1.1	1.4	1.7	V
Reverse current	V _R = 5 V	I _R		0.01	10	μA
Input capacitance	f = 1 MHz, V _F = 0 V	C _I		55		pF
OUTPUT						
High level supply current (single channel)	V _E = 0.5 V, I _F = 0 mA	I _{CCH}		4.1	7	mA
	V _E = V _{CC} , I _F = 0 mA	I _{CCH}		3.3	6	mA
High level supply current (dual channel)	I _F = 0 mA	I _{CCH}		6.5	12	mA
Low level supply current (single channel)	V _E = 0.5 V, I _F = 10 mA	I _{CCL}		4	7	mA
	V _E = V _{CC} , I _F = 10 mA	I _{CCL}		3.3	6	mA
Low level supply current (dual channel)	I _F = 10 mA	I _{CCL}		6.5	12	mA
High level output current	V _E = 2 V, V _O = 5.5 V, I _F = 250 μA	I _{OH}		0.002	1	μA
Low level output voltage	V _E = 2 V, I _F = 5 mA, I _{OL} (sinking) = 13 mA	V _{OL}		0.2	0.6	V
Input threshold current	V _E = 2 V, V _O = 5.5 V, I _{OL} (sinking) = 13 mA	I _{TH}		2.4	5	mA
High level enable current	V _E = 2 V	I _{EH}		- 0.6	- 1.6	mA
Low level enable current	V _E = 0.5 V	I _{EL}		- 0.8	- 1.6	mA
High level enable voltage		V _{EH}	2			V
Low level enable voltage		V _{EL}			0.8	V

Note

- Minimum and maximum values are testing requirements. Typical values are characteristics of the device and are the result of engineering evaluation. Typical values are for information only and are not part of the testing requirements.

SWITCHING CHARACTERISTICS						
PARAMETER	TEST CONDITION	SYMBOL	MIN.	TYP.	MAX.	UNIT
Propagation delay time to high output level	R _L = 350 Ω, C _L = 15 pF	t _{PLH}	20	48	75 ⁽¹⁾	ns
		t _{PLH}			100	ns
Propagation delay time to low output level	R _L = 350 Ω, C _L = 15 pF	t _{PHL}	25	50	75 ⁽¹⁾	ns
		t _{PHL}			100	ns
Pulse width distortion	R _L = 350 Ω, C _L = 15 pF	t _{PHL} - t _{PLH}		2.9	35	ns
Propagation delay skew	R _L = 350 Ω, C _L = 15 pF	t _{PSK}		8	40	ns
Output rise time (10 % to 90 %)	R _L = 350 Ω, C _L = 15 pF	t _r		23		ns
Output fall time (90 % to 10 %)	R _L = 350 Ω, C _L = 15 pF	t _f		7		ns
Propagation delay time of enable from V _{EH} to V _{EL}	R _L = 350 Ω, C _L = 15 pF, V _{EL} = 0 V, V _{EH} = 3 V	t _{ELH}		12		ns
Propagation delay time of enable from V _{EL} to V _{EH}	R _L = 350 Ω, C _L = 15 pF, V _{EL} = 0 V, V _{EH} = 3 V	t _{EHL}		11		ns

Notes

- Over recommended temperature (T_{amb} = - 40 °C to + 100 °C), V_{CC} = 5 V, I_F = 7.5 mA unless otherwise specified. All typicals at T_{amb} = 25 °C, V_{CC} = 5 V.
- (1) 75 ns applies to the 6N137 only, a JEDEC registered specification

6N137, VO2601, VO2611, VO2630, VO2631, VO4661

Vishay Semiconductors High Speed Optocoupler, Single and Dual, 10 MBd

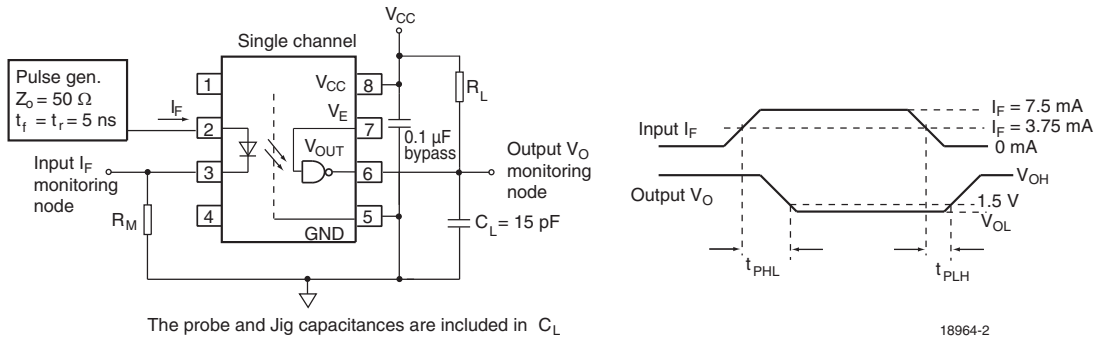

The probe and Jig capacitances are included in C_L
 Fig. 1 - Single Channel Test Circuit for t_{PLH} , t_{PHL} , t_r and t_f

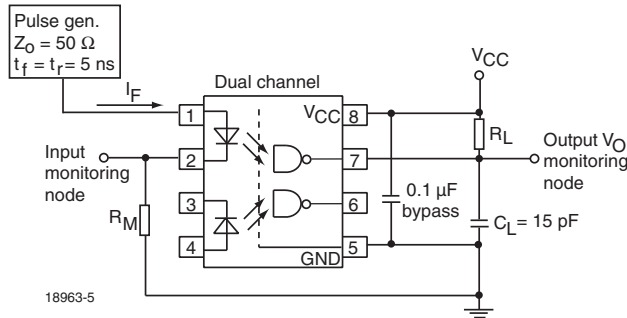
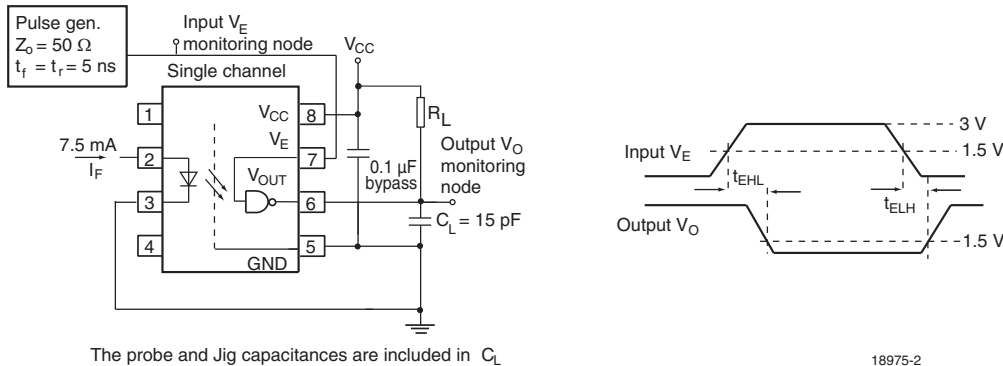

Fig. 2 - Dual Channel Test Circuit for t_{PLH} , t_{PHL} , t_r and t_f



The probe and Jig capacitances are included in C_L
 Fig. 3 - Single Channel Test Circuit for t_{EHL} , and t_{ELH}

COMMON MODE TRANSIENT IMMUNITY						
PARAMETER	TEST CONDITION	SYMBOL	MIN.	TYP.	MAX.	UNIT
Common mode transient immunity (high)	$ V_{CM} = 10 \text{ V}$, $V_{CC} = 5 \text{ V}$, $I_F = 0 \text{ mA}$, $V_{O(\min.)} = 2 \text{ V}$, $R_L = 350 \Omega$, $T_{\text{amb}} = 25 \text{ }^\circ\text{C}$ (1)	$ CM_H $	100			V/ μs
	$ V_{CM} = 50 \text{ V}$, $V_{CC} = 5 \text{ V}$, $I_F = 0 \text{ mA}$, $V_{O(\min.)} = 2 \text{ V}$, $R_L = 350 \Omega$, $T_{\text{amb}} = 25 \text{ }^\circ\text{C}$ (2)	$ CM_H $	5000	10 000		V/ μs
	$ V_{CM} = 1 \text{ kV}$, $V_{CC} = 5 \text{ V}$, $I_F = 0 \text{ mA}$, $V_{O(\min.)} = 2 \text{ V}$, $R_L = 350 \Omega$, $T_{\text{amb}} = 25 \text{ }^\circ\text{C}$ (3)	$ CM_H $	15 000	25 000		V/ μs
	$ V_{CM} = 10 \text{ V}$, $V_{CC} = 5 \text{ V}$, $I_F = 7.5 \text{ mA}$, $V_{O(\max.)} = 0.8 \text{ V}$, $R_L = 350 \Omega$, $T_{\text{amb}} = 25 \text{ }^\circ\text{C}$ (1)	$ CM_L $	100			V/ μs
	$ V_{CM} = 50 \text{ V}$, $V_{CC} = 5 \text{ V}$, $I_F = 7.5 \text{ mA}$, $V_{O(\max.)} = 0.8 \text{ V}$, $R_L = 350 \Omega$, $T_{\text{amb}} = 25 \text{ }^\circ\text{C}$ (2)	$ CM_L $	5000	10 000		V/ μs
	$ V_{CM} = 1 \text{ kV}$, $V_{CC} = 5 \text{ V}$, $I_F = 7.5 \text{ mA}$, $V_{O(\max.)} = 0.8 \text{ V}$, $R_L = 350 \Omega$, $T_{\text{amb}} = 25 \text{ }^\circ\text{C}$ (3)	$ CM_L $	15 000	25 000		V/ μs

Notes

- (1) For 6N137 and VO2630
- (2) For VO2601 and VO2631
- (3) For VO2611 and VO4661

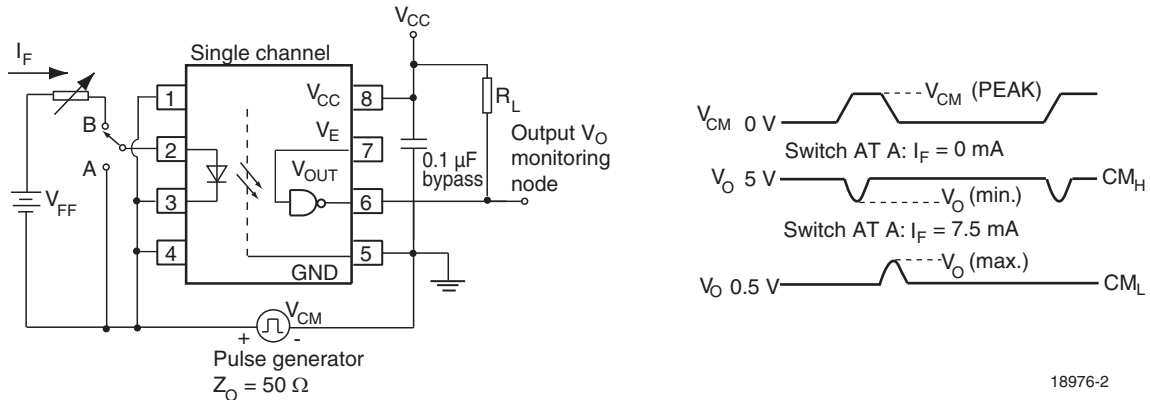

Fig. 4 - Single Channel Test Circuit for Common Mode Transient Immunity

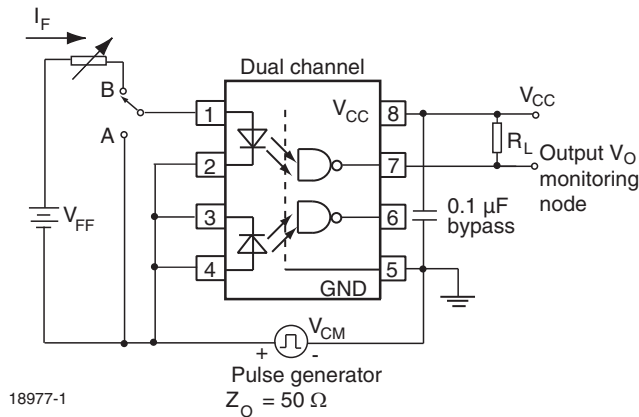

Fig. 5 - Dual Channel Test Circuit for Common Mode Transient Immunity

SAFETY AND INSULATION RATINGS						
PARAMETER	TEST CONDITION	SYMBOL	MIN.	TYP.	MAX.	UNIT
Climatic classification	according to IEC 68 part 1			55/100/21		
Comparative tracking index		CTI	175		399	
Peak transient overvoltage		V_{IOTM}	8000			V
Peak insulation voltage		V_{IORM}	890			V
Safety rating - power output		P_{SO}			500	mW
Safety rating - input current		I_{SI}			300	mA
Safety rating - temperature		T_{SI}			175	°C
Creepage distance	Standard DIP-8		7			mm
Clearance distance	Standard DIP-8		7			mm
Creepage distance	400 mil DIP-8		8			mm
Clearance distance	400 mil DIP-8		8			mm
Insulation thickness, reinforced rated	per BSI 60950		0.2			mm

Note

- As per IEC 60747-5-5, §7.4.3.8.1, this optocoupler is suitable for “safe electrical insulation” only within the safety ratings. Compliance with the safety ratings shall be ensured by means of protective circuits.

TYPICAL CHARACTERISTICS ($T_{amb} = 25\text{ }^{\circ}\text{C}$, unless otherwise specified)

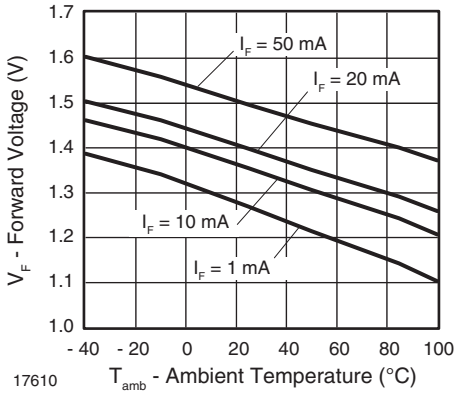

Fig. 6 - Forward Voltage vs. Ambient Temperature

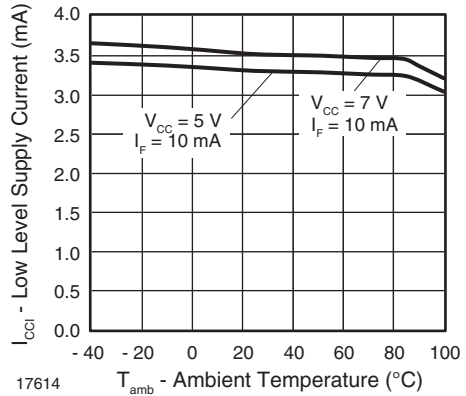

Fig. 9 - Low Level Supply Current vs. Ambient Temperature

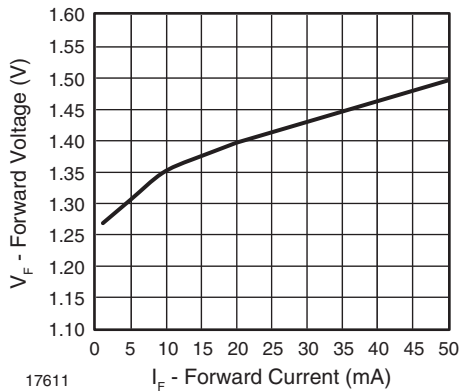

Fig. 7 - Forward Voltage vs. Forward Current

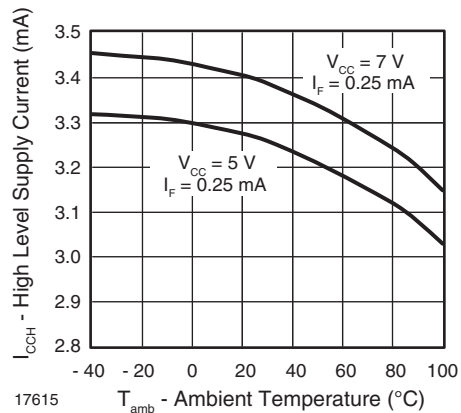

Fig. 10 - High Level Supply Current vs. Ambient Temperature

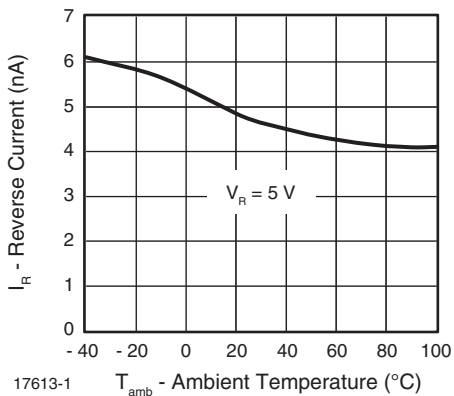

Fig. 8 - Reverse Current vs. Ambient Temperature

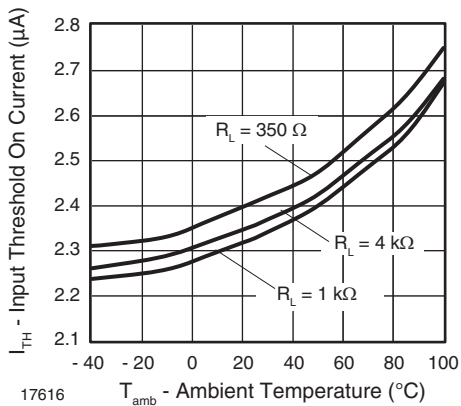

Fig. 11 - Input Threshold On Current vs. Ambient Temperature



6N137, VO2601, VO2611, VO2630, VO2631, VO4661

High Speed Optocoupler, Single and Dual, Vishay Semiconductors
10 MBd

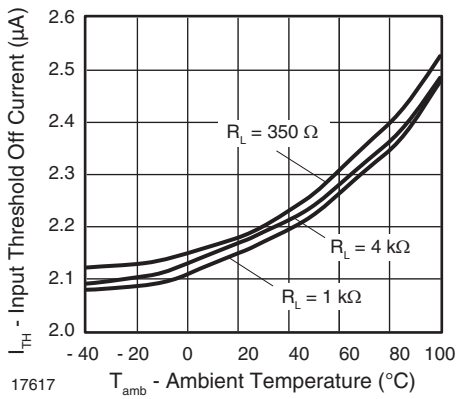

Fig. 12 - Input Threshold Off Current vs. Ambient Temperature

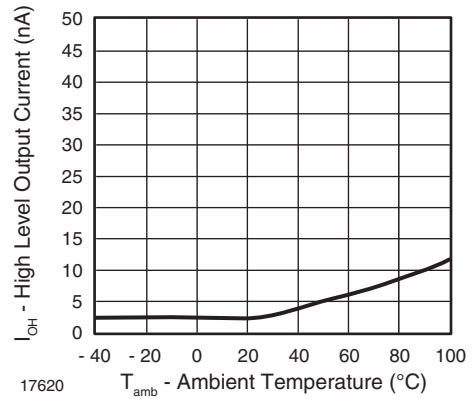

Fig. 15 - High Level Output Current vs. Ambient Temperature

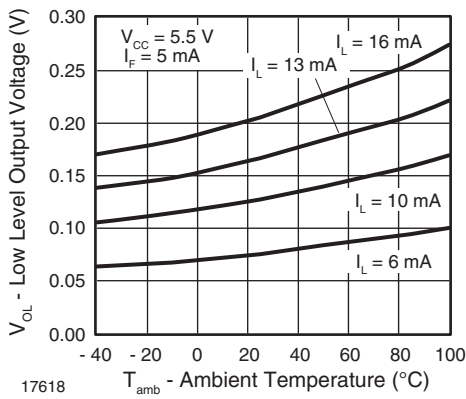

Fig. 13 - Low Level Output Voltage vs. Ambient Temperature

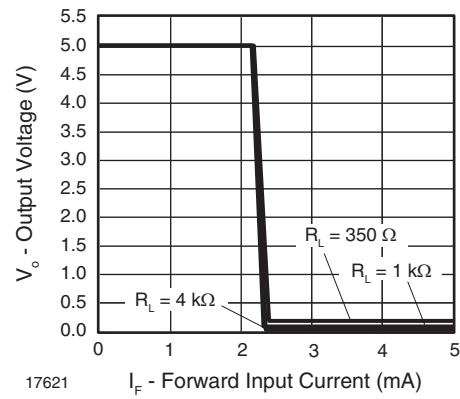

Fig. 16 - Output Voltage vs. Forward Input Current

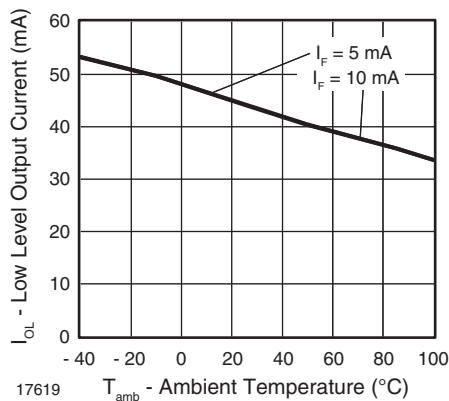

Fig. 14 - Low Level Output Current vs. Ambient Temperature

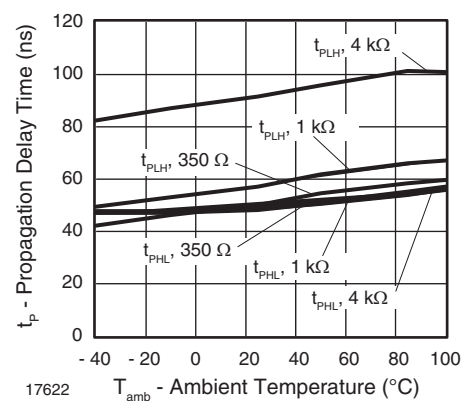

Fig. 17 - Propagation Delay vs. Ambient Temperature

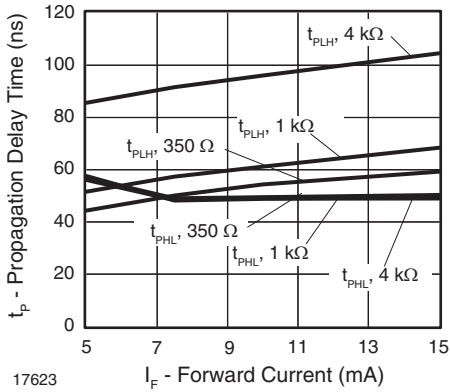

Fig. 18 - Propagation Delay vs. Forward Current

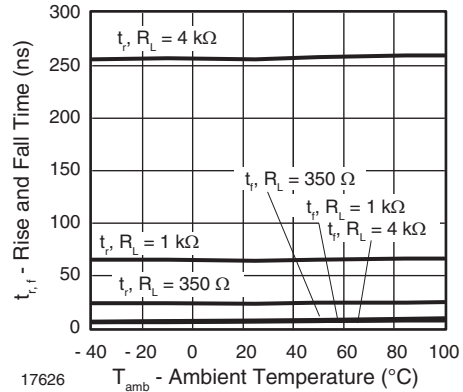

Fig. 21 - Rise and Fall Time vs. Ambient Temperature

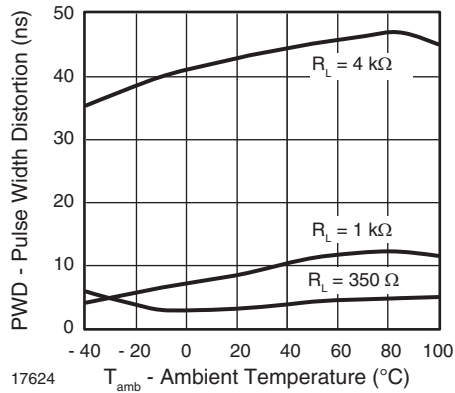

Fig. 19 - Pulse Width Distortion vs. Ambient Temperature

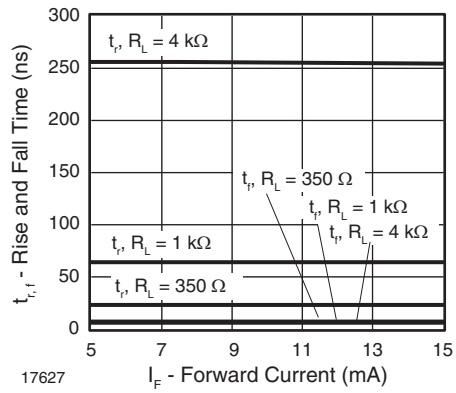

Fig. 22 - Rise and Fall Time vs. Forward Current

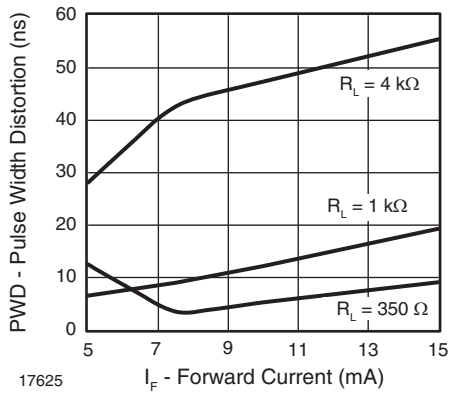

Fig. 20 - Pulse Width Distortion vs. Forward Current

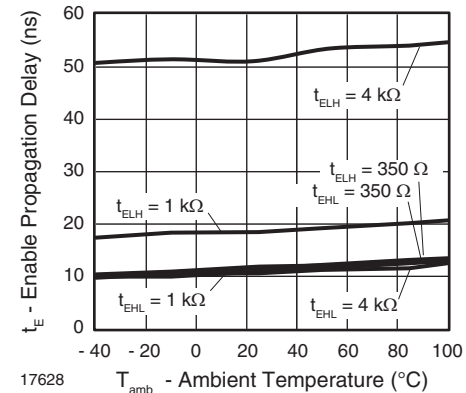

Fig. 23 - Enable Propagation Delay vs. Ambient Temperature



6N137, VO2601, VO2611, VO2630, VO2631, VO4661

High Speed Optocoupler, Single and Dual, Vishay Semiconductors
10 MBd

PACKAGE DIMENSIONS in millimeters

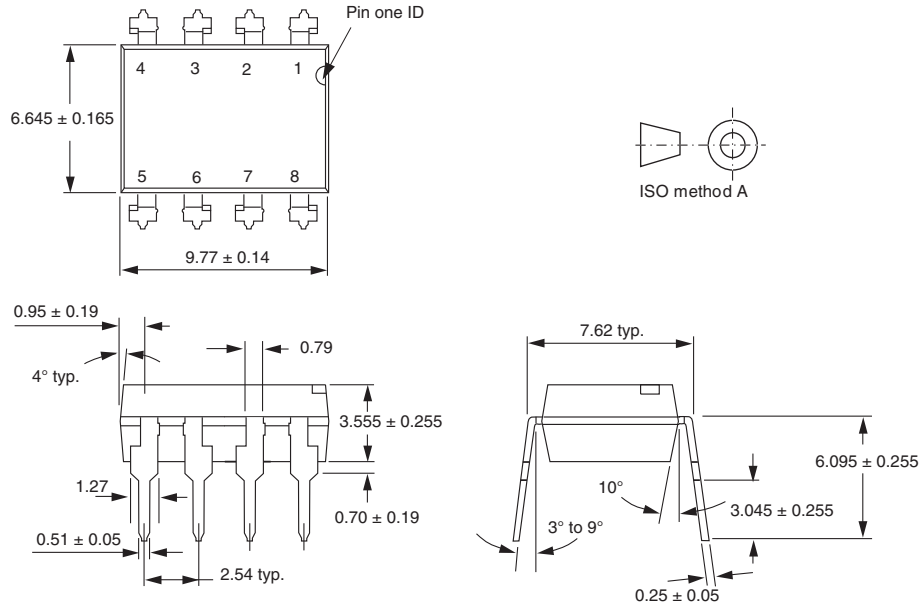

i178006

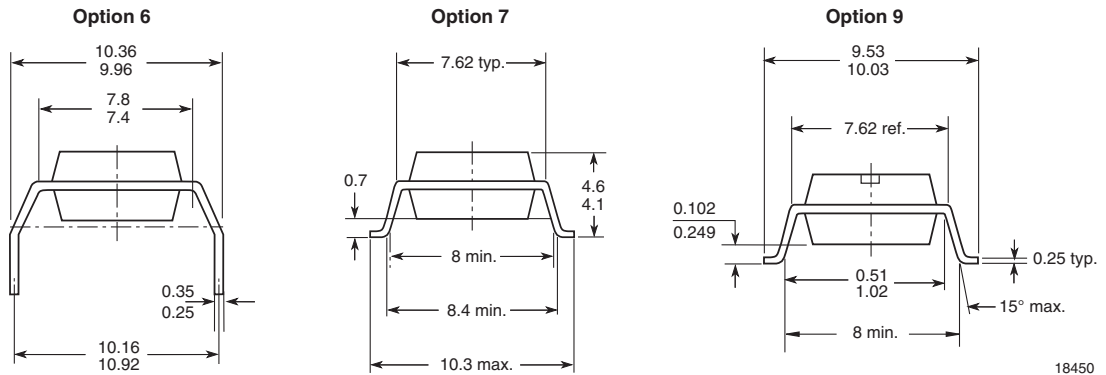

18450

PACKAGE MARKING



21764-44

Notes

- Option 1 and VDE logos are only marked on option 1 parts.
- Tape and reel suffix (T) is not part of the package marking.



Disclaimer

ALL PRODUCT, PRODUCT SPECIFICATIONS AND DATA ARE SUBJECT TO CHANGE WITHOUT NOTICE TO IMPROVE RELIABILITY, FUNCTION OR DESIGN OR OTHERWISE.

Vishay Intertechnology, Inc., its affiliates, agents, and employees, and all persons acting on its or their behalf (collectively, "Vishay"), disclaim any and all liability for any errors, inaccuracies or incompleteness contained in any datasheet or in any other disclosure relating to any product.

Vishay makes no warranty, representation or guarantee regarding the suitability of the products for any particular purpose or the continuing production of any product. To the maximum extent permitted by applicable law, Vishay disclaims (i) any and all liability arising out of the application or use of any product, (ii) any and all liability, including without limitation special, consequential or incidental damages, and (iii) any and all implied warranties, including warranties of fitness for particular purpose, non-infringement and merchantability.

Statements regarding the suitability of products for certain types of applications are based on Vishay's knowledge of typical requirements that are often placed on Vishay products in generic applications. Such statements are not binding statements about the suitability of products for a particular application. It is the customer's responsibility to validate that a particular product with the properties described in the product specification is suitable for use in a particular application. Parameters provided in datasheets and/or specifications may vary in different applications and performance may vary over time. All operating parameters, including typical parameters, must be validated for each customer application by the customer's technical experts. Product specifications do not expand or otherwise modify Vishay's terms and conditions of purchase, including but not limited to the warranty expressed therein.

Except as expressly indicated in writing, Vishay products are not designed for use in medical, life-saving, or life-sustaining applications or for any other application in which the failure of the Vishay product could result in personal injury or death. Customers using or selling Vishay products not expressly indicated for use in such applications do so at their own risk and agree to fully indemnify and hold Vishay and its distributors harmless from and against any and all claims, liabilities, expenses and damages arising or resulting in connection with such use or sale, including attorneys fees, even if such claim alleges that Vishay or its distributor was negligent regarding the design or manufacture of the part. Please contact authorized Vishay personnel to obtain written terms and conditions regarding products designed for such applications.

No license, express or implied, by estoppel or otherwise, to any intellectual property rights is granted by this document or by any conduct of Vishay. Product names and markings noted herein may be trademarks of their respective owners.