

Universal AC/DC Photoelectric Sensor with Built-in Timer

- Easy-to-wire terminal block
- Built-in timer offers selectable ON-delay, OFF-delay and one-shot
- Relay or transistor output models
- Polarized, through-beam and diffuse models
- Light-ON/Dark-ON operation switch selectable

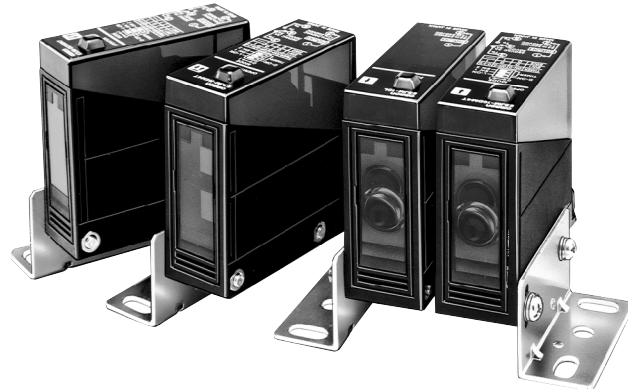

Ordering Information

■ SENSORS WITHOUT TIMER

Method of detection		Through-beam	Polarized retroreflective	Diffuse reflective
Sensing distance		10 m (32.8 ft)	4 m (13.1 ft)	70 cm (2.3 ft)
Output type	Relay	E3JM-10M4-US	E3JM-R4M4-US	E3JM-DS70M4-US
	NPN transistor	E3JM-10S4-US	E3JM-R4S4-US	E3JM-DS70S4-US
	PNP transistor	E3JM-10R4-US	E3JM-R4R4-US	E3JM-DS70R4-US

■ SENSORS WITH BUILT-IN TIMER

Method of detection		Through-beam	Polarized retroreflective	Diffuse reflective
Sensing distance		10 m (32.8 ft)	4 m (13.1 ft)	70 cm (2.3 ft)
Output type	Relay	E3JM-10M4T-US	E3JM-R4M4T-US	E3JM-DS70M4T-US
	NPN transistor	E3JM-10S4T-US	E3JM-R4S4T-US	E3JM-DS70S4T-US
	PNP transistor	E3JM-10R4T-US	E3JM-R4R4T-US	E3JM-DS70R4T-US

■ ACCESSORIES

Description	Part number
Mounting bracket for E39-R1 reflector	E39-L7
Small reflector for retroreflective sensors	E39-R3
Glass-bead reflector with tape backing for retroreflective sensors	E39-RSB

■ REPLACEMENT PARTS

Description	Part number
Mounting bracket (supplied with each sensor)	E39-L53
Reflector (supplied with retroreflective sensors)	E39-R1

Specifications

Part number		E3JM-10□4□-US	E3JM-R4□4□-US	E3JM-DS70□4□-US
Method of detection		Through-beam	Polarized retroreflective	Diffuse reflective
Supply voltage		24 to 240 VAC ±10%, 50/60 Hz 12 to 240 VDC, 10% max. ripple peak-to-peak		
Current consumption		Emitter: 1 W max. Receiver: 2 W max.	2 W max.	2 W max.
Sensing distance		10 m (32.8 ft)	4 m (13.1 ft) with E39-R1 reflector (supplied)	70 cm (2.3 ft) with 20 x 20 cm (7.9 x 7.9 in) white mat paper
Light source		Infrared LED	Polarized red LED	Infrared LED
Detectable object type		Opaque, 16 mm (0.63 in) minimum	Opaque, 56 mm (2.2 in) minimum with E39-R1	Opaque and translucent
Operation mode		Light-ON/Dark-ON, switch selectable		
Sensitivity adjustment		Fixed	Fixed	Adjustable
Mutual interference protection		Not provided		
Control output	Contact	Type	SPDT relay (E3JM-□□M4□-US)	
		Max. load	3 A, 250 VAC maximum (p.f. = 1)	
		Min. load	10 mA, 5 VDC minimum	
		Response time	30 ms for ON, 30 ms for OFF (models without timer) 0.1 to 5 sec (adjustable) ON-delay, OFF-delay or one-shot (models with timer)	
	DC solid-state	Type	NPN open collector solid-state output (E3JM-□□S4□-US) PNP open collector solid-state output (E3JM-□□R4□-US)	
		Max. load	100 mA, 48 VDC max.	
		Max. ON-state voltage drop	2 V max.	
		Response time	5 ms max. (models without timer) 0.1 to 5 seconds (adjustable) ON-delay, OFF-delay or one-shot (models with timer)	
Timing functions	Type	ON-delay, OFF-delay, and one-shot; switch selectable (E3JM-□□□4T-US)		
	Range	0.1 to 5 seconds		
Circuit protection	Output short-circuit	Provided on DC solid-state output models (E3JM-□□R4□-US and E3JM-□□S4□-US)		
	DC power supply reverse polarity	Not provided		
Indicators		Light Incident (red LED) on models without timer (E3JM-□□□4-US) Output Operation (red LED) on models with timer (E3JM-□□□4T-US)		
Materials	Lens	Plastic, PMMA		
	Case	Plastic, ABS base/PMMA cover		
Mounting		Two side mount through hole or mounting bracket E39-L53 (supplied)		
Connections	Conduit	1/2-14 NPT; use 5-conductor cable of 6 to 8 mm (0.24 to 0.32 in) OD		
Weight		Emitter: 110 g (3.9 oz.) Receiver: 130 g (4.6 oz.)	130 g (4.6 oz.)	130 g (4.6 oz.)
Enclosure ratings	UL	—		
	NEMA	—		
	IEC 144	IP66		
Approvals	UL	Recognized, File Number E41515		
	CSA	Certified, File Number LR45951		
Ambient temperature	Operating	-25° to 55°C (-13° to 131°F)		
	Storage	-30° to 70°C (-22° to 158°F)		

■ OUTPUT CIRCUIT DIAGRAMS

Relay Output (E3JM-□□M4□-US)

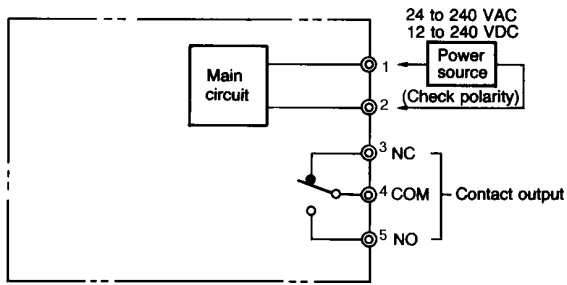

NPN Transistor Output (E3JM-□□S4□-US)

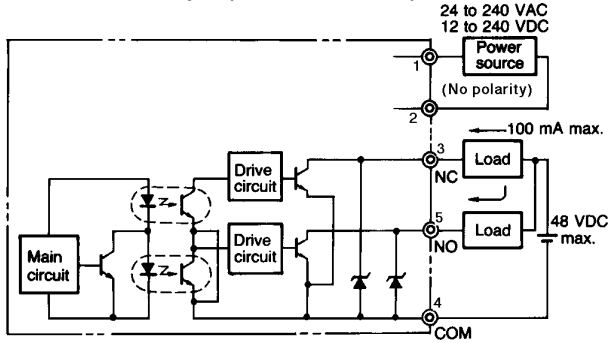

PNP Transistor Output (E3JM-R4□-US)

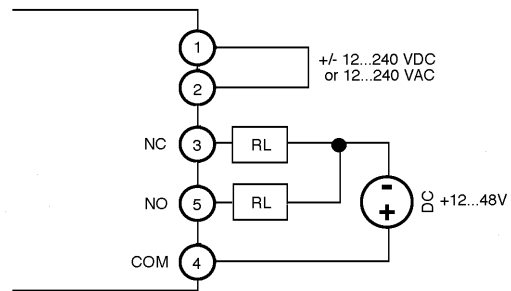

■ CONNECTIONS

Through-beam type

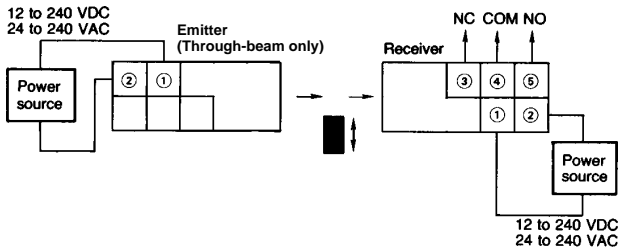

■ TIMING CHARTS

Sensors without Timer

Switch configuration

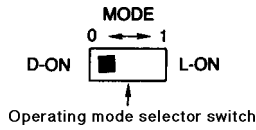

Switch setting

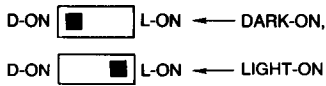

Timing chart

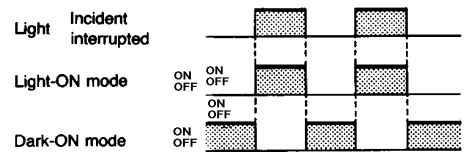

Sensor with Timer

The timing function cannot be disabled. Allow a minimum 0.1 sec. delay in response time if set for ON-delay.

Switch configuration

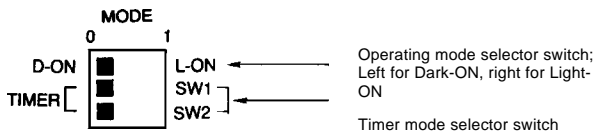

Timer chart and switch setting

<p>Timer mode setting</p>		<p>ON-delay</p> <p>Both SW1 and SW2 at "0"</p>	<p>OFF-delay</p> <p>Only SW2 at "1"</p>	<p>One-shot delay</p> <p>Only SW1 at "1", which overrides either setting of SW2</p>
<p>Light</p> <p>Incident Interrupted</p>	<p>Light-ON operation mode</p> <p>Output (NO circuit)</p> <p>ON OFF</p>	<p>ON-delay</p>	<p>OFF-delay</p>	<p>One-shot delay</p>
<p>Dark-ON operation mode</p> <p>Output (NO circuit)</p> <p>ON OFF</p>	<p>ON-delay</p>	<p>OFF-delay</p>	<p>One-shot delay</p>	

Engineering Data

■ EXCESS GAIN

Through-beam type
E3JM-10□□4□-US

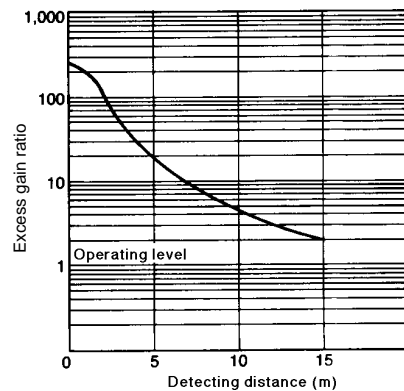

Retroreflective type
E3JM-R4□4□-US

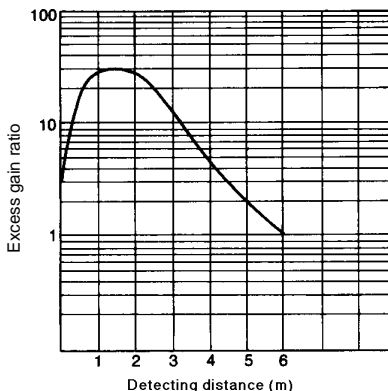

Diffuse reflective type
E3JM-DS70□4□-US

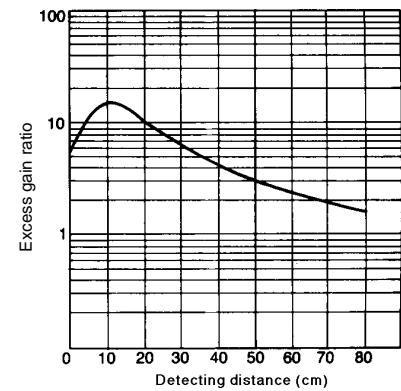

Excess Gain (continued)

Retroreflective with Optional reflectors E39-R3 and E39-RSB

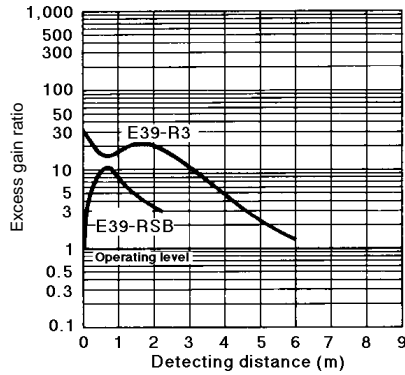

OPERATING RANGE

Through-beam type

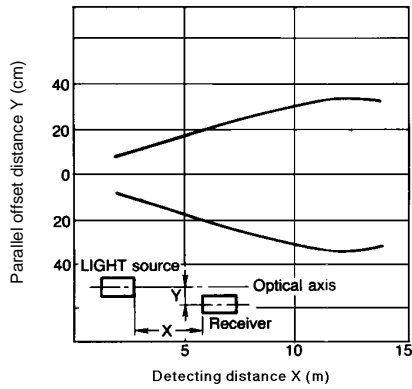

Retroreflective type

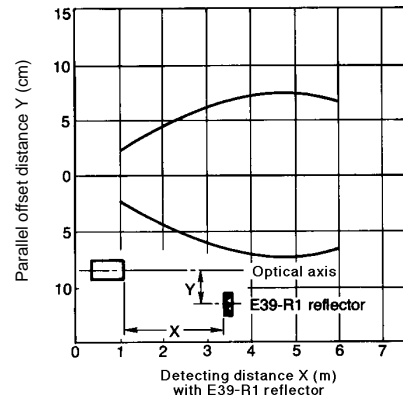

Diffuse reflective type

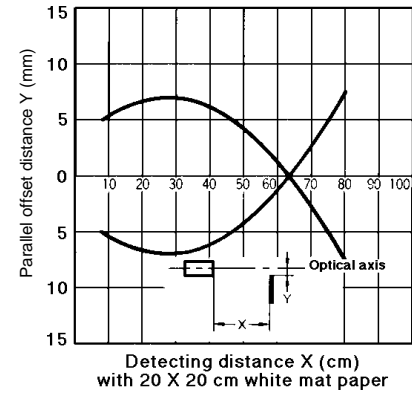

Dimensions

Unit: mm (inch)

THROUGH-BEAM TYPE

E3JM-10□4□-US

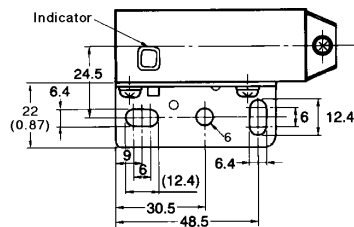
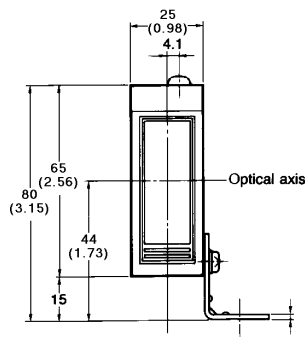
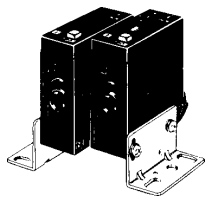

Mounting holes

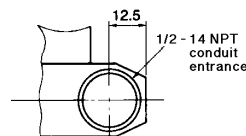
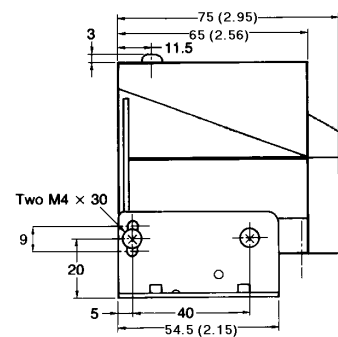
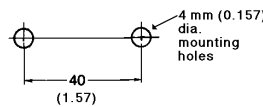

DIMENSIONS (continued)

REFLECTIVE TYPES

E3JM-R4□4□-US,
E3JM-DS70□4□-US

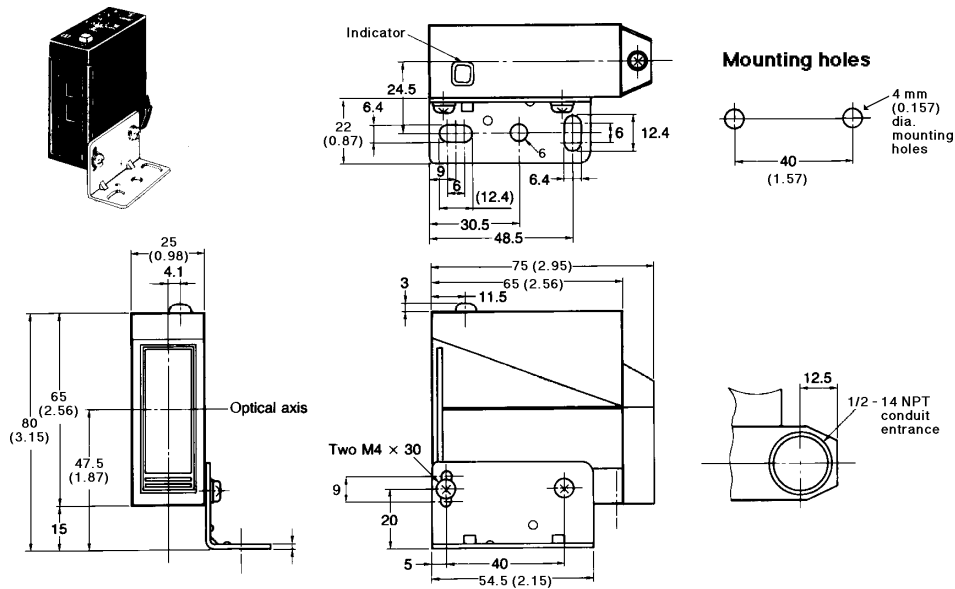

ACCESSORIES

E39-R1 Reflector (supplied with retroreflective sensors)

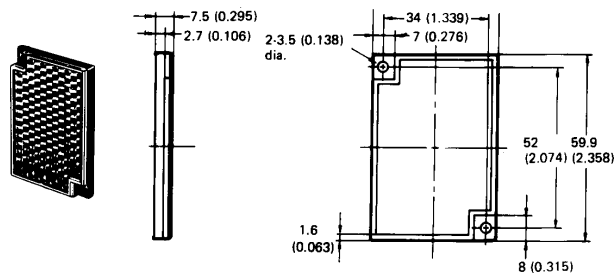

E39-L7 Mounting bracket for E39-R1 reflector

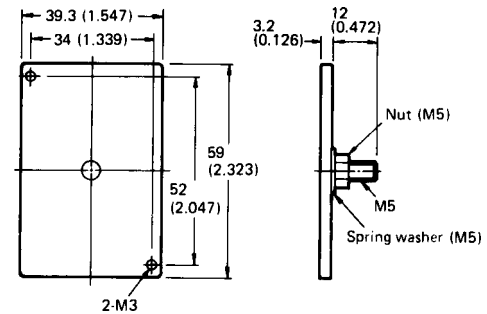

■ OPTIONAL REFLECTORS

The following optional reflectors for polarized retroreflective sensors provide space saving installation.

E39-R3 Small reflector

Reflector	E39-R3 small	E39-RSB glass bead
Detecting distance with E3JM-R4	3.5 m (11.5 ft)	25 cm to 1 m 9.8 in. to 3.28 ft.

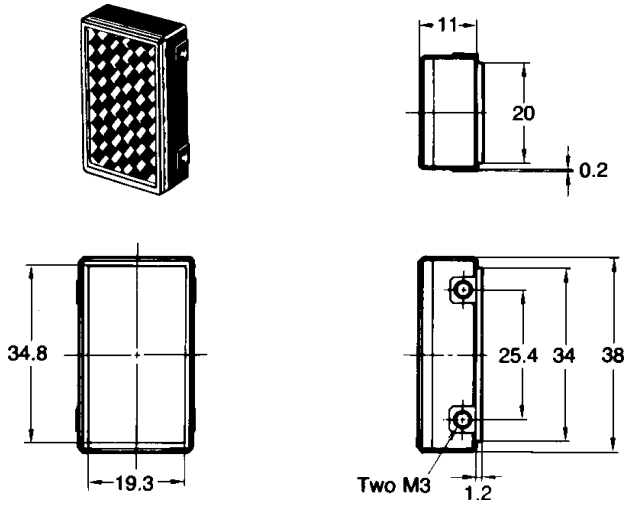

E39-RSB Glass Bead, adhesive back reflector

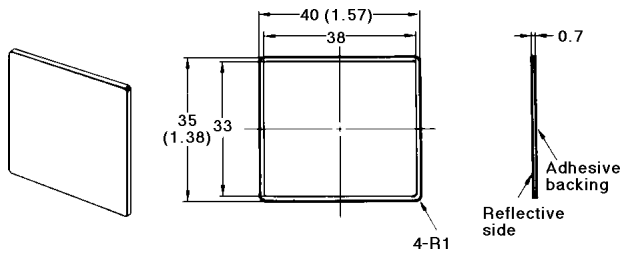

OMRON

OMRON ELECTRONICS LLC

One East Commerce Drive
Schaumburg, IL 60173

1-800-55-OMRON

Cat. No. CEDSAX4

11/01

OMRON ON-LINE

Global - <http://www.omron.com>
USA - <http://www.omron.com/oei>
Canada - <http://www.omron.com/oci>

Specifications subject to change without notice.

OMRON CANADA, INC.

885 Milner Avenue
Scarborough, Ontario M1B 5V8

416-286-6465

Printed in the U.S.A.