

WAVELENGTH SENSOR WS-7.56-TO5

SPECIAL CHARACTERISTICS

- Two p-n junctions constructed vertically
- Operating range: 450 - 900 nm
- Spectral resolution: 0.01 nm
- Specially for monochromatic light

PARAMETERS

Part No.	WS-7.56-TO5
Active Area	7.56 mm ² 2.75 x 2.75 mm
Operating Range	450 - 900 nm
Spectral Resolution	0.01 nm
Bias Voltage U_R	Max. 5V
Saturation Level	Max. 150 μ W (0V) Max. 3 mW (5V)
Dark Current I_{R0} @ $E = 0lx$, $U_R = 5V$	Max. 100 nA Typ. 10 nA
Spectral Responsivity Diode 1 @ 550 nm	Typ. 0.2 A/W
Spectral Responsivity Diode 2 @ 890 nm	Typ. 0.45 A/W
Junction Capacitance C_j Diode 1 @ 0V	Typ. 1 nF
Junction Capacitance C_j Diode 2 @ 0V	Typ. 0.1 nF
Rise Time t_r Diode 1 @ 0V, 1k Ω	Typ. 10 μ s
Rise Time t_r Diode 2 @ 0V, 1k Ω	Typ. 1 μ s
Quotient Q Depending on U_{Bias} @ $\lambda = 635$ nm	In case of short circuit typ. 5 nm/V
Temperature Coefficient of Quotient Q @ $\lambda = 635$ nm, 0V	In case of short circuit typ. 1 nm/K
Operating Temperature	-20 ... +55°C
Storage Temperature	-40 ... +100°C
Shunt Resistance @ 22°C @ $U_R = 10$ mV	
Diode 1	Typ. 2 G Ω
Diode 2	Typ. 100 M Ω

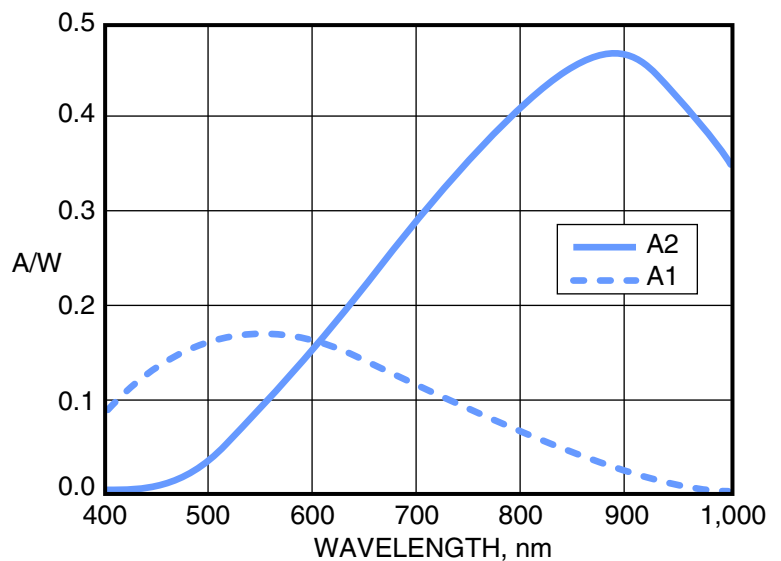
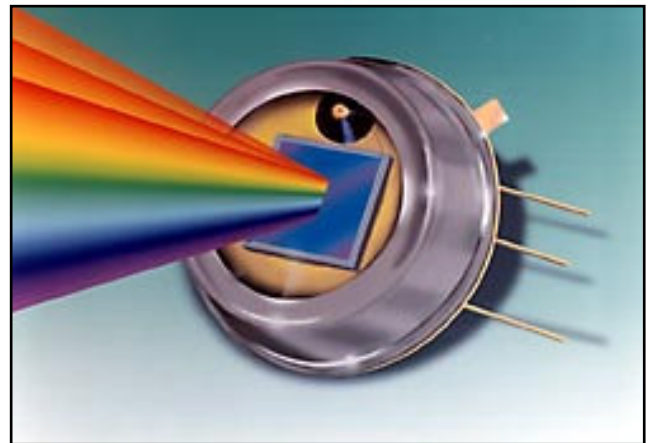

SPECTRAL RESPONSIVITY (A/W)

WAVELENGTH SENSOR WS-7.56-TO5

SPECIAL CHARACTERISTICS

The PSS WS-7.56-TO5 Wavelength Sensor has two p-n junctions constructed vertically on a common silicon substrate. The upper diode has enhanced blue and the lower enhanced red response. Absorbed radiation between 450 and 900 nm thus generates two photocurrents proportional to the wavelength of the incident light. The quotient of the signals is independent of the light level up to the saturation point. The wavelength of impinging monochromatic light or the spectral density peak of polychromatic light can therefore be determined.

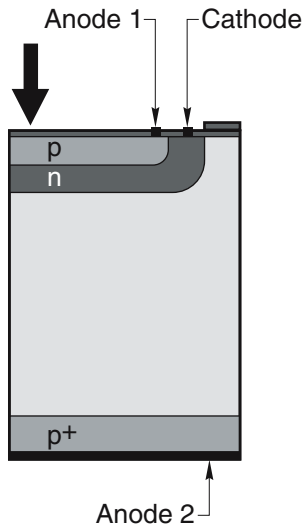

APPLICATION TIPS

During photovoltaic operation ($U_R = 0V$), an intensity independence for Q (quotient of both the photo currents) is expected for a radiation up to 150 μW . This range can be increased up to 3 mW by operating with bias voltage ($U_R = \text{max. } 5V$). A possible application circuit is shown.

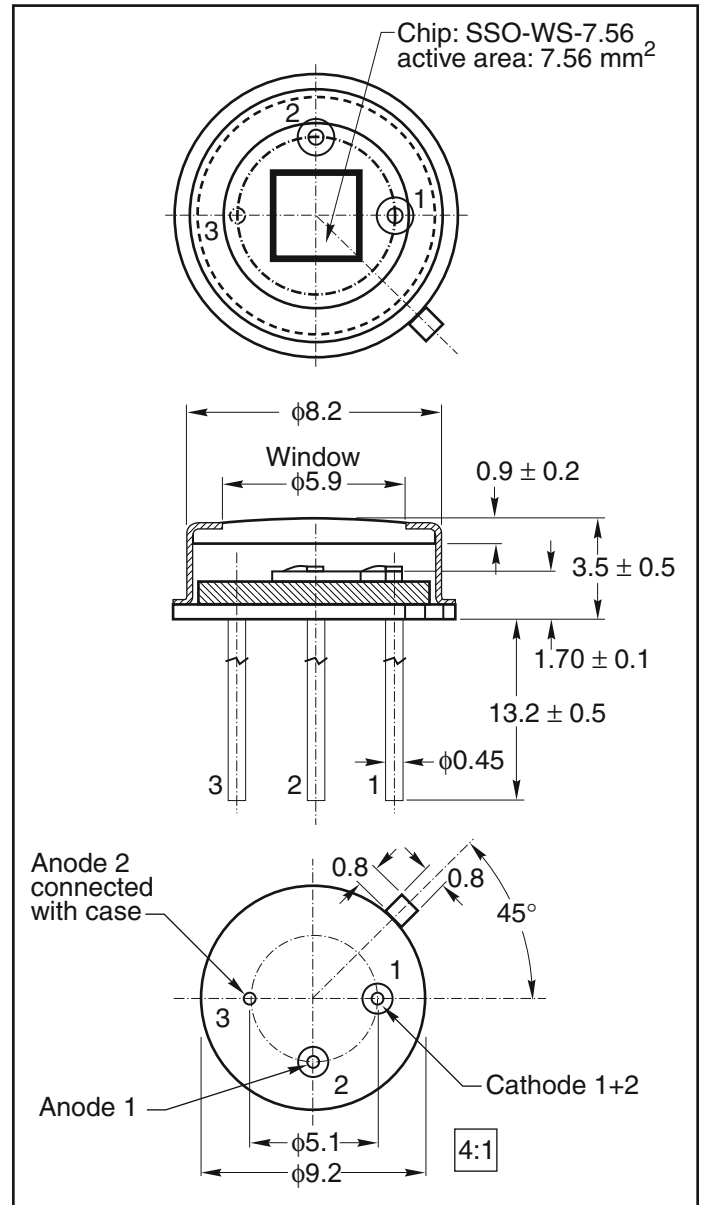
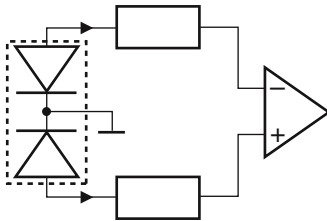

PACKAGE: TO5

HANDLING PRECAUTIONS

Soldering temperature	260°C for max. 10s. The device must be protected against solder flux vapour!
ESD - protection	Only small danger for the device. Standard precautionary measures are sufficient.
Storage	Store devices in conductive foam.