

BL-4000 SERIES

White Developer Kit - 230VAC

New!

Lamina Light Engines

As the market leader in the development and manufacture of super-bright LED light engines, Lamina brings solid state lighting to applications which until now were only possible with traditional lighting sources.

Lamina's LED light engines are manufactured by combining high brightness LEDs from industry-leading LED manufacturers with Lamina's proprietary packaging technology, multilayer Low Temperature Co-Fired Ceramic on Metal (LTCC-M). LTCC-M is a breakthrough in thermal performance for LED packaging technology, a key factor in determining LED life and reliability. Unmatched thermal performance coupled with package interconnectivity allows Lamina to densely cluster multiple LEDs to achieve exceptionally high luminous intensity in very small footprints. Lamina's light engines are available in white, RGB and monochrome, from 1W to 100W, and also in custom packages up to 1000W.

Lamina LED light engines provide:

- HIGH LUMINOUS FLUX IN SMALL FOOTPRINT
- SUPERIOR THERMAL PERFORMANCE FOR IMPROVED RELIABILITY
- LONG LIFE AND HIGH LUMEN MAINTENANCE
- SUSTAINABLE DESIGN – ROHS COMPLIANT¹
- CUSTOM SIZES AND SHAPES AVAILABLE

BL-4000 White 5500K Developer Kit – 230VAC

Lamina's new Developer Kit series enables users to quickly discover the world of solid state lighting and realize the power of Lamina's super-bright LED light engines. This kit is intended for the rapid evaluation and prototyping of LED lighting solutions based on the Lamina BL-4000 Warm White or White 5500K Light Engines. The kit is fully assembled and includes everything needed to jump start your design efforts. As shown in the Developer Kit Contents table and photo, this comprehensive kit includes a Warm White and White 5500K Light Engine Assemblies, a matched, commercially available, LED constant current driver, Optics, and prewired DC connections from the Warm White light engine to the driver.

- LAMINA'S BL-4000 WARM WHITE LED LIGHT ENGINE DELIVERING 95 LUMENS IN TRUE WARM WHITE (3000 °K) FROM A SINGLE POINT
 - LAMINA'S BL-4000 WHITE LED LIGHT ENGINE DELIVERING 120 LUMENS IN WHITE (5500 °K) FROM A SINGLE POINT
 - BOTH BL-4000 WHITE LIGHT ENGINES ARE SOLDERED TO LAMINA'S EZCONNECT BOARD AND ATTACHED TO LAMINA'S RADIAL HEAT SINK
 - PHILIPS (ADVANCE) 700mA 17W CONSTANT CURRENT DRIVER FOR 230VAC/50Hz
 - LAMINA NARROW, MEDIUM, AND WIDE OPTICS IN OPTIC HOLDERS FOR EASY ATTACHMENT TO THE EZCONNECT BOARD
 - FULLY ASSEMBLED AND READY TO PLUG IN
1. ALL LAMINA LIGHT ENGINES ARE ROHS COMPLIANT. LAMINA IS CONVERTING LAMINA ACCESSORIES AND DEVELOPER KITS TO BE ROHS COMPLIANT WELL IN ADVANCE OF THE 1 JULY 2006 DEADLINE.



TYPICAL APPLICATIONS

ARCHITECTURAL LIGHTING

- DECORATIVE AND ACCENT
- COVE AND UNDER-SHELF
- GARDEN AND PATHWAY
- STEP LIGHTS

MACHINE VISION

DISPLAY BACKLIGHTING

FIBER OPTIC ILLUMINATION

TASK LIGHTING

- DESK LAMPS
- FLASHLIGHTS

MEDICAL

AUTOMOTIVE

AIRCRAFT

SIGNALS

SECURITY LIGHTING

To see how you can realize all these design benefits, to request a sample, or to speak with an engineer about your design, contact Lamina at 800.808.5822 or 609.265.1401 or visit www.laminaceramics.com.

BL-4000 White Developer Kit – 230VAC Contents P/N DK-04D0-0395

Item	Description	QTY	Lamina Part Number	Notes
1	Warm White Light Engine Assembly BL-4000 Warm White (P/N BL-42D1-0408) Light Engine soldered to EZ-Connect Board and attached to Radial Heat Sink, .75" thick, with screws and thermal joint compound	1	EZ-42D1-0418 Light Engine attached to EZ-Connect Board HS-4075-0345 .752 "(1.9cm) Thick Radial Heat Sink	
2	White 5500K Light Engine Assembly BL-4000 White 5500K (P/N BL-42D0-0304) Light Engine soldered to EZ-Connect Board and attached to Radial Heat Sink, .75" thick, with screws and thermal joint compound	1	EZ-42D0-0353 Light Engine attached to EZ-Connect Board HS-4075-0345 0.75"(1.9cm) Thick Radial Heat Sink	
3	Xitanium™ 700mA 17W 230VAC/50Hz Constant Current Driver with Euro style AC Power Cord	1	210-0143	PHILIPS (ADVANCE) 9137 001 81403
4	DC/DC Connection Cable (1 prewired, 2 spare)	3	210-0145	TYCO/AMP 1365323-1
5	Narrow Optic w/holder, 10° Beam Angle	1	FHS-HNB1-LC01-H	
6	Medium Optic w/holder, 30° Beam Angle	1	FHS-HMB1-LC01-H	
7	Wide Optic w/holder, 45° Beam Angle	1	FHS-HWB1-LC01-H	
8	UK style Adapter Plug, 230VAC	1	210-0135	Franzus NW-135C
9	ANZAC/China style Adapter Plug, 230VAC	1	210-0134	Franzus NW-2C

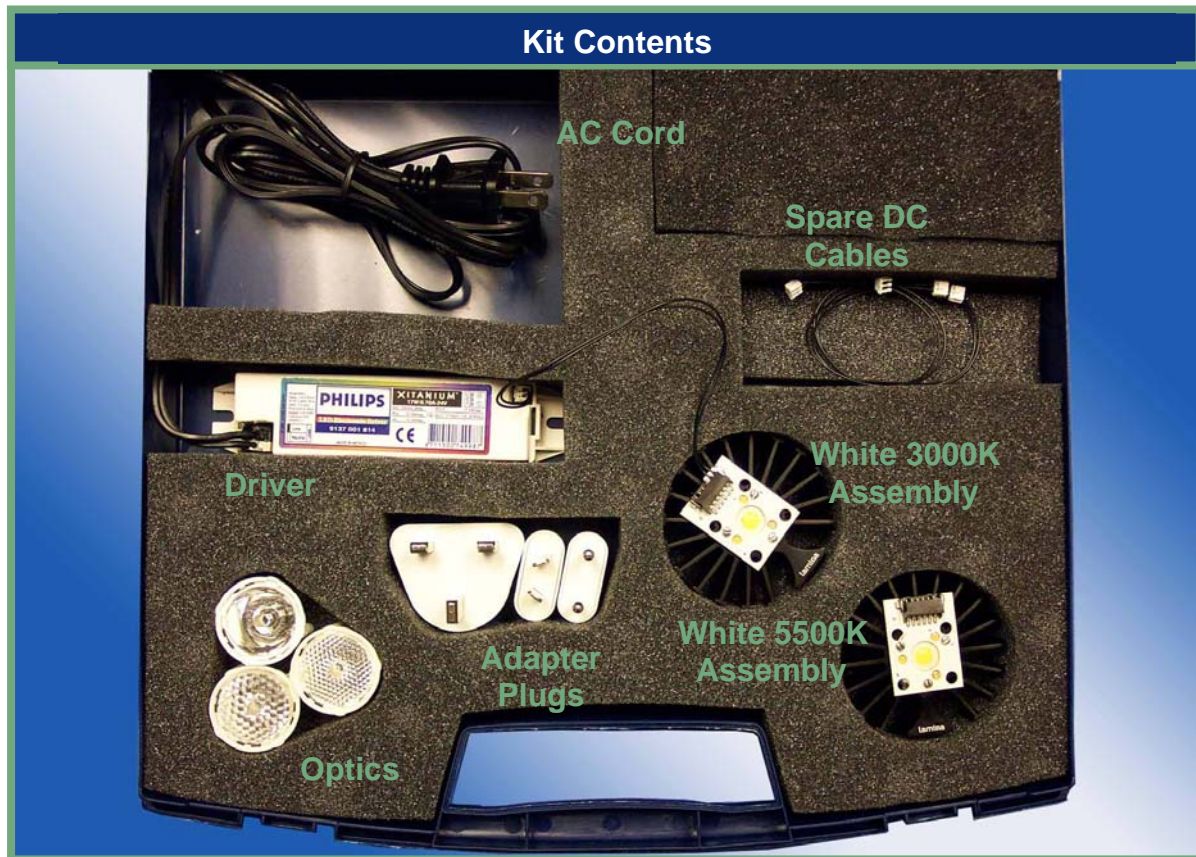

To see how you can realize all these design benefits, to request a sample, or to speak with an engineer about your design, contact Lamina at 800.808.5822 or 609.265.1401 or visit www.laminaceramics.com.

Operating Instructions

1. Remove the Warm White Light Engine Assembly and driver from the kit case and place them on a suitable work surface near an AC power outlet. Please verify the DC/DC connection cable is correctly attached between the light engine and driver. Also, verify the AC power cord is properly connected to the driver. See the photos below for the proper connections.
2. **Careful, Lamina LED Light Engines are extremely BRIGHT. Before powering up, direct the light engine away from your eyes, place an optic over the light engine, or wear suitable protective eyewear.** Plug the driver's AC power cord into a 230VAC/50Hz power outlet using the adapter plugs if required. The light engine will now be illuminating.
3. To test the included optics, insert the legs of the optic holder into the four corner holes in Lamina's EZConnect board. The EZConnect board is designed to align the optic to the center of the light engine and allow the optic to rest on the light engine surface.
4. To try the White 5500K Light Engine Assembly, unplug the AC power and detach the DC/DC connection cable from the Warm White Assembly. Plug the DC connection cable into the White 5500K Assembly per the DC Connection between Light Engine and Driver photo below. Please refer to 2. and 3., directly above, for the power up and optics test procedure.

NOTE: Please unplug the AC power before connecting or disconnecting the LED Light Engine to avoid potential damage to the Light Engine or the driver.

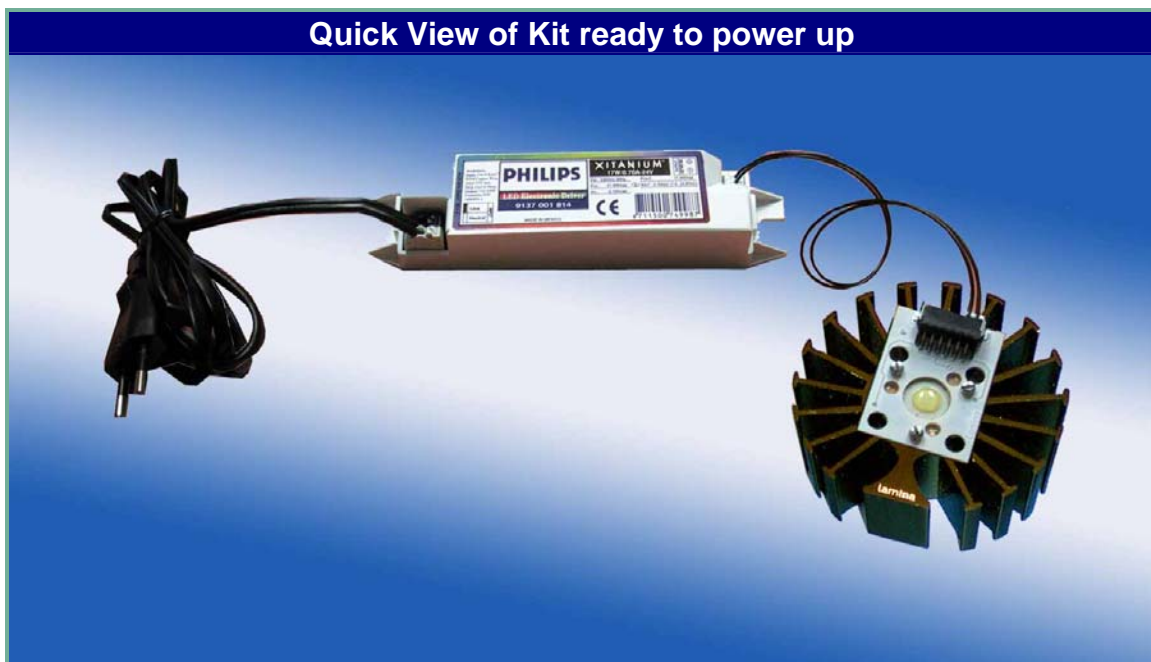

To see how you can realize all these design benefits, to request a sample, or to speak with an engineer about your design, contact Lamina at 800.808.5822 or 609.265.1401 or visit www.laminaceramics.com.

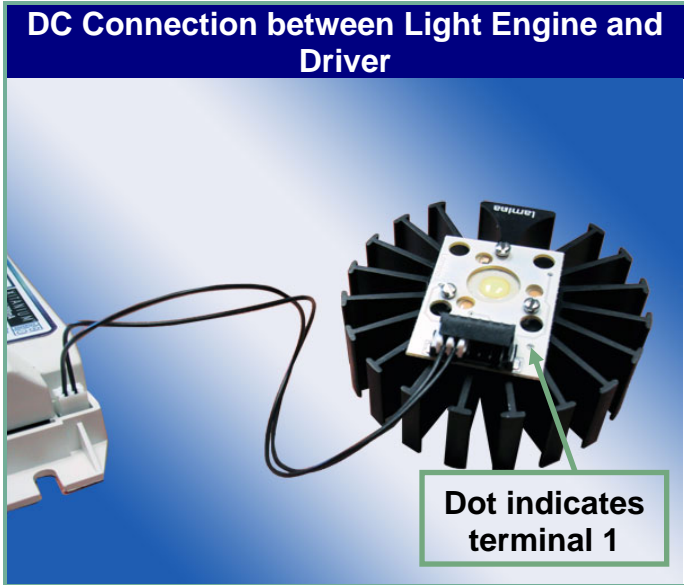

DC Connection between Light Engine and Driver

A close up of the DC connection between the light engine and the driver is shown in the above photo. Although the DC/DC connection cable is keyed to facilitate correct attachment to the Light Engine Assembly, two connection orientations are possible. The proper connection is to terminals 5 and 6 of the EZConnect board; this is the side opposite from the dot indicating terminal 1. If the cable is improperly connected to terminals 1 and 2 of the EZConnect board, the light engine cannot be powered, but this should not result in damage to the light engine. Two spare DC/DC connection cables are included for prototyping.

BL-4000 Optics

Lamina narrow, medium, and wide optics in optics holders are included in this kit. The optics can be identified using the following drawing with top views.

Top Views of Optics

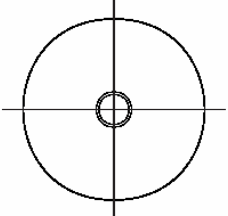
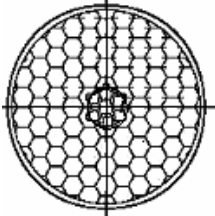
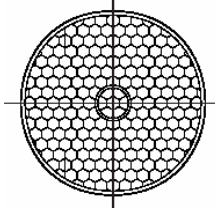
Narrow Beam lens: FHS-HNB1-LC01-H	Medium Beam lens: FHS-HMB1-LC01-H	Wide Beam lens: FHS-HWB1-LC01-H
		
Flat surface	2.6mm hexagonal shaped microlens array	1.7mm hexagonal shaped microlens array

For further information about the optics including full specifications and permanent attachment, please obtain the Lamina BL-4000 Optics data sheet by visiting Lamina's website, www.LaminaCeramics.com.

To see how you can realize all these design benefits, to request a sample, or to speak with an engineer about your design, contact Lamina at 800.808.5822 or 609.265.1401 or visit www.laminaceramics.com.

Attaching to Your Fixture or Assembly

The Light Engine Assembly can be mounted in several configurations. Ideally, the light engine should be configured horizontally, thereby allowing the heat to radiate through the vertically oriented fins. Alternate assembly positions are also possible. The orientation of the fins will determine how efficiently the heat sink can dissipate the thermal energy.

Configuration options with BL-4000 White Light Engines

Both BL-4000 White light engines can be connected in series and driven simultaneously using the included 700mA 17W constant current driver. This is useful for a side by side comparison of the light properties of the BL-4000 Warm White and White 5500K light engines. Two spare DC connection cables are provided to construct a cable for this purpose. A simple way to construct the cable is to cut the two spare cables in half and stripping the wire lead ends about 3/8" (9mm) on three of the halves. Plug the connectors of these three cable halves into the driver and each light engine assembly. Finally, connect the stripped leads as indicated in the figure below by twisting the stripped ends together.

Connecting 2 Lamina BL-4000 White Light Engines

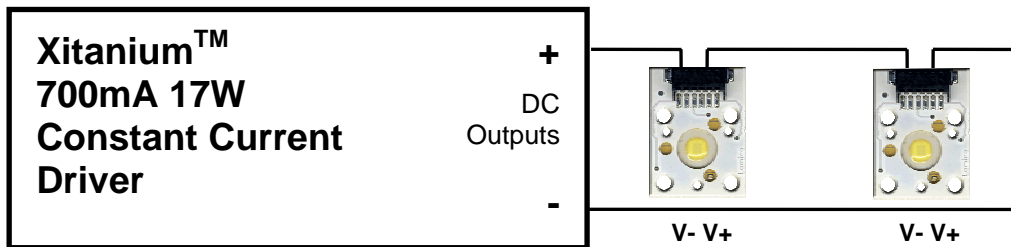

Handling Precaution

Contact with the silicone based encapsulant on the surface of the light engine must be avoided to prevent damage. Do not apply pressure to the silicone based encapsulant or allow it to come into contact with sharp objects. Lamina LED light engines must be handled from the sides.

Further Prototyping Information and Support

Additional information regarding the BL-4000 series of Light Engines, Optics, Heat Sinks, Accessories, Developer Kits, compatible Drivers, and Applications Notes can be found by visiting Lamina's website, www.LaminaCeramics.com.

Also, please visit Lamina's website, www.LaminaCeramics.com, for more information on Lamina's complete line of LED light engines and Lamina's worldwide distribution network.

Lamina Ceramics • 120 Hancock Lane • Westampton, NJ 08060 • USA

Specifications subject to change without notice • ©2005 Lamina Ceramics, Inc. • FM-0128 Rev A 11.15.05

To see how you can realize all these design benefits, to request a sample, or to speak with an engineer about your design, contact Lamina at 800.808.5822 or 609.265.1401 or visit www.laminaceramics.com.