

Tsan

10W Series

燦

“Tsan [Can] is the English translation for the Chinese word representing a Great Gathering of Light or a Combination of Great Lights. These words are proper metaphors in reference to this multi-chip design. Chinese culture firmly believes that success is a by product when individual parts work together as a whole.”

Introduction

The Tsan series is a SMD, high power, multi-chip device with very low thermal resistance as a result of the ceramic substrate. The low thermal resistance allows for excellent thermal conductivity and thermal management, which in turn allows the LED to be driven at conditions suitable for optimal performance. When driven at optimal performance, this high brightness density package exude enough lumens output for any lighting application such as general illumination, spot, signal, industrial and commercial lighting. The Tsan series is one of the most promising devices Everlight high power product offering and is ready to face the challenges of Solid-State Lighting.

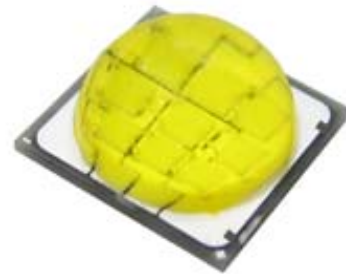

Features

- ◆ Small package with high efficiency
- ◆ Typical view angle: 135°
- ◆ ESD protection up to 2KV
- ◆ Soldering method: SMT
- ◆ Binning Parameters: Luminous Flux , Forward Voltage, and Chromaticity
- ◆ Moisture Sensitivity Level: 1
- ◆ RoHS compliant
- ◆ Reliability testing conforms to IESNA LM80 Lumen maintenance test method

Applications

- ◆ General Lighting
- ◆ Task Lighting
- ◆ Indoor and Outdoor Lighting
- ◆ Signal Lighting/Beacon Lighting
- ◆ Architectural Lighting
- ◆ Spot Lighting

Table of Contents

Product Nomenclature	3
Absolute Maximum Ratings.....	4
JEDEC Moisture Sensitivity.....	4
Luminous Flux Characteristics for the Tsan Series	5
PN of the Tsan series: White LEDs	6
Product Binning.....	7
White Bin Structure	8
Forward Voltage Bins	12
Optical Characteristics	13
Mechanical Dimension	14
Pad Configuration	15
Reflow Soldering Characteristics	16
Wavelength Characteristics.....	17
Typical Light Output Characteristic vs. Thermal Pad Temperature.....	18
Typical Electrical Characteristics.....	20
Typical Relative Luminous Flux vs. Forward Current	20
Typical Wavelength & CCT Shift Characteristics vs. Forward Current	21
Current Derating Curves	22
Typical Radiation Patterns	23
Emitter Tape Packaging	26
Emitter Reel Packaging.....	27
Product Labeling	27
Revision History	28

Product Nomenclature

The product name is designated as below:

ELTS– ABCDE – FGHIJ – V1234

Designation:

AB = min. luminous flux (lm) or radiation power (mW) performance

C = radiation pattern ^[1]

D = color ^[2]

E = power consumption ^[3]

F = reserved for future product offerings

G = internal code

H = packaging type ^[4]

IJ = internal code

V = forward voltage bin

1234 = color bin or CCT bin

Notes

1. Table of radiation patterns

Symbol	Description
1	Lambertian
2	Others

2. Table of color offerings:

Symbol	Color	Dominant wavelength range
C	Cool-White	4745~7050K
N	Neutral-White	3710~4745K
M	Warm-White	2580~3710K

3. Table of power consumptions:

Symbol	Description
6	10W

4. Table of packaging types:

Symbol	Description
P	Tape
B	Tube
T	Tray

Absolute Maximum Ratings

Parameter	Symbol	Ratings	Unit
Max. DC Forward Current (mA)	I_F	1200 _[1]	mA
Max. Peak Pulse Current (mA)	I_{Pulse}	2000	mA
Max. ESD Resistance	V_B	2000	V
Reverse Voltage	V_r	Note 2	V
Thermal Resistance	R_{th}	3	°C/W
Max. Junction Temperature	T_j	125 _[3]	°C
Operating Temperature	T_{opr}	-40 ~ +90 _{[4] [5]}	°C
Storage Temperature	T_{stg}	-40 ~ +100	°C
Max. Soldering Temperature	T_{sol}	260	°C
Max. Allowable Reflow Cycles	n/a	3	cycles

Notes:

1. Maximum forward current for 10W is 1200mA ($T_{Thermal Pad}=25^{\circ}C$).
2. The Tsan series LEDs are not designed for reverse bias operation.
3. Maximum junction temperature is 125°C for Cool-White, Neutral-White, and Warm-White LEDs.
4. Maximum Operating Temperature (Thermal Pad) is 90°C for Cool-White, Neutral-White, and Warm-White LEDs.
5. Avoid operating Tsan LEDs at maximum operating temperature exceeding 1 hour.

JEDEC Moisture Sensitivity

Level	Floor Life		Soak Requirements Standard	
	Time (hours)	Conditions	Time (hours)	Conditions
1	unlimited	$\leq 30^{\circ}C / 85\% RH$	168 (+5/-0)	85°C / 85% RH

Luminous Flux Characteristics for the Tsan series

Color	Part Number	10W	
		Minimum Luminous Flux(lm)[1]	Drive Current (mA)
Cool White 6500	ELTS-P62C6	800	1050
	ELTS-P72C6	850	1050
	*ELTS-P82C6	900	1050
Cool White 5700	ELTS-P62C6	800	1050
	ELTS-P72C6	850	1050
	*ELTS-P82C6	900	1050
Warm White 3000	ELTS-N92M6	650	1050
	ELTS-P12M6	675	1050
	*ELTS-P22M6	700	1050

Note:

1. Luminous flux measurement tolerance: $\pm 10\%$.
2. The data of luminous flux measured at thermal pad=25°C
3. Typical luminous flux or light output performance is operated within the condition guided by this datasheet.
4. Please contact sales for timing, availability and P/N's marked with an asterisk " * ".

PN of the Tsan series: White LEDs

The table below lists part numbers for the Everlight Tsan series 10W White LED. All parts listed match ANSI binning standards. Bin offerings of 6500K, 5700K and 3000K are listed and currently available. CRI is also listed with variations from typical 70 to 80. These clearly listed binning options allow for proper design and implementation into lighting applications.

The Order Codes below are currently available White Tsan LEDs.

For Example: If you order product using P/N **ELTS-P62C6-0LPGS-T5700**, you will be specifying:



Color Variant	CRI	CCT	Forward Voltage (V)	Minimum Luminous Flux (lm)
Cool White	75	57K-1 ~ 57K-2 ~ 57K-3 ~ 57K-4	9.0~10.0(R2) 10.0~11.0(R3) 11.0~12.0(R4)	800

White, Tsan series LEDs at 1050mA are listed below

Color	Order Code of ELTS	Minimum Luminous Flux (lm)	CCT (K)	Forward Voltage (V)	CRI (Typical)
Cool White 6500	ELTS-P62C6-0LPGS-T6500	800	6500-1~6500-4	9 ~ 12	75
	ELTS-P72C6-0LPGS-T6500	850	6500-1~6500-4	9 ~ 12	75
	*ELTS-P82C6-0LPGS-T6500	900	6500-1~6500-4	9 ~ 12	75
Cool White 5700	ELTS-P62C6-0LPGS-T5700	800	5700-1~5700-4	9 ~ 12	75
	ELTS-P72C6-0LPGS-T5700	850	5700-1~5700-4	9 ~ 12	75
	*ELTS-P82C6-0LPGS-T5700	900	5700-1~5700-4	9 ~ 12	75
Warm White 3000	ELTS-N92M6-0LPGS-T3000	650	3000-1~3000-4	9 ~ 12	80
	ELTS-P12M6-0LPGS-T3000	675	3000-1~3000-4	9 ~ 12	80
	*ELTS-P22M6-0LPGS-T3000	700	3000-1~3000-4	9 ~ 12	80

Notes:

1. CRI measurement tolerance: ± 5 .
2. Please contact sales for timing and availability of P/N's marked with an asterisk "*".

Product Binning

Luminous Flux Bins

Group	Bin	Minimum Photometric Flux (lm)	Maximum Photometric Flux (lm)
E	1	4	5
	2	5	6
	3	6	8
	4	8	10
	5	10	13
	6	13	17
	7	17	20
	8	20	23
	9	23	27
F	1	27	33
	2	33	39
	3	39	45
	4	45	52
	5	52	60
	6	60	70
	7	70	80
	8	80	90
	9	90	100
J	1	100	110
	2	110	120
	3	120	130
	4	130	140
	5	140	150
	6	150	160
	7	160	180
	8	180	200
	9	200	225

Group	Bin	Minimum Photometric Flux (lm)	Maximum Photometric Flux (lm)
K	1	225	250
	2	250	275
	3	275	300
	4	300	325
	5	325	350
	6	350	375
	7	375	400
	8	400	425
	9	425	450
N	1	450	475
	2	475	500
	3	500	525
	4	525	550
	5	550	575
	6	575	600
	7	600	625
	8	625	650
	9	650	675
P	1	675	700
	2	700	725
	3	725	750
	4	750	775
	5	775	800
	6	800	850
	7	850	900
	8	900	950
	9	950	1000
S	1	1000	1100
	2	1100	1200
	3	1200	1300
	4	1300	1400
	5	1400	1600
	6	1600	1800
	7	1800	2000

Note: Currently available brightness bins for White LEDs are highlighted and bolded.

White Bin Structure

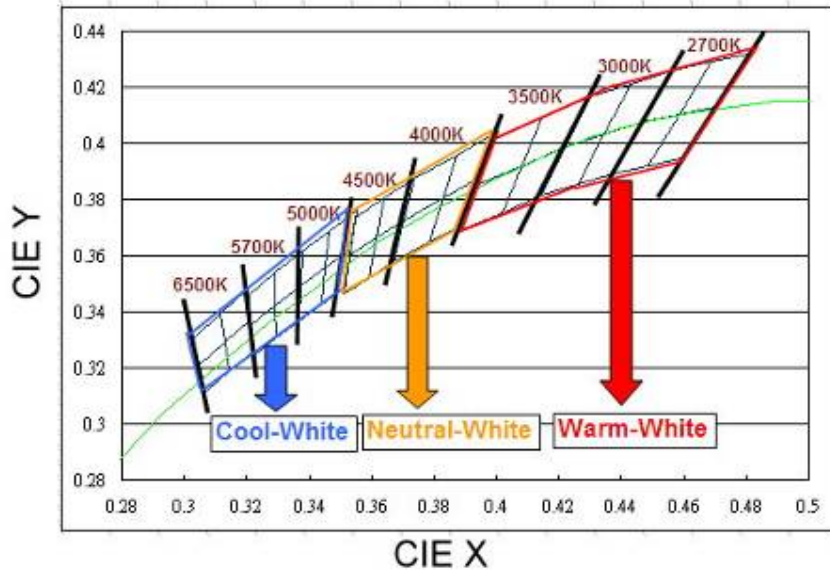

Chromaticity specification defined by ANSI

Notes:

1. The CCT range of Cool-White varies from 4745K to 7050K.
2. The CCT range of Neutral-White varies from 3710K to 4745K.
3. The CCT range of Warm-White varies from 2580K to 3710K
4. Color coordinates measurement allowance : ± 0.01
5. Color bins are defined at $I_f=1050$ mA

Cool-White Bin Structure

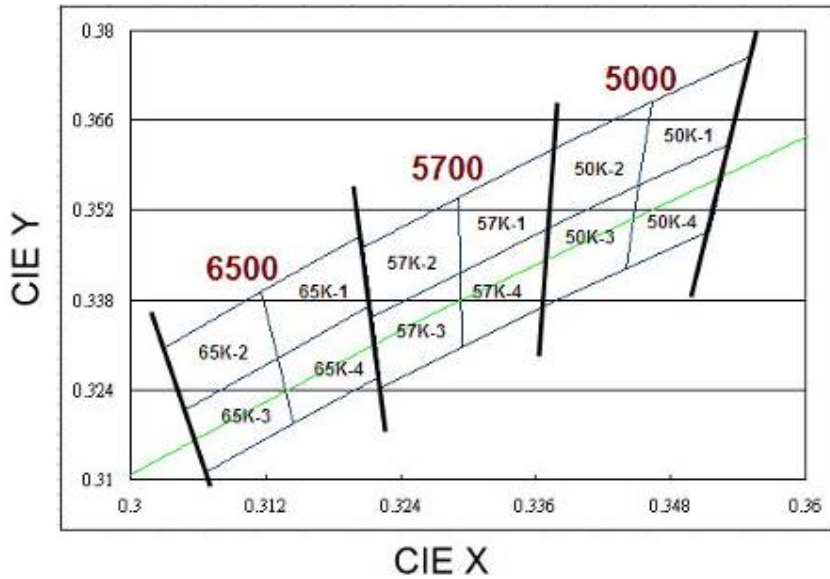

Cool-White Bin Coordinates

5000K

Bin	CIE X	CIE Y
50K-1	0.346	0.369
	0.345	0.356
	0.353	0.362
	0.355	0.376
Reference Range: 4745~5000K		

Bin	CIE X	CIE Y
50K-2	0.338	0.362
	0.337	0.349
	0.345	0.356
	0.346	0.369
Reference Range: 5000~5310K		

Bin	CIE X	CIE Y
50K-4	0.345	0.356
	0.344	0.343
	0.352	0.349
	0.353	0.362
Reference Range: 4745~5000K		

Bin	CIE X	CIE Y
50K-3	0.337	0.349
	0.337	0.337
	0.344	0.343
	0.345	0.356
Reference Range: 5000~5310K		

5700K

Bin	CIE X	CIE Y
57K-1	0.329	0.354
	0.329	0.342
	0.337	0.349
	0.338	0.362
Reference Range: 5310~5700K		

Bin	CIE X	CIE Y
57K-2	0.321	0.346
	0.321	0.335
	0.329	0.342
	0.329	0.354
Reference Range: 5700~6020K		

Bin	CIE X	CIE Y
57K-4	0.329	0.342
	0.329	0.331
	0.337	0.337
	0.337	0.349
Reference Range: 5310~5700K		

Bin	CIE X	CIE Y
57K-3	0.321	0.335
	0.322	0.324
	0.329	0.331
	0.329	0.342
Reference Range: 5700~6020K		

6500K

Bin	CIE X	CIE Y
65K-1	0.312	0.339
	0.313	0.329
	0.321	0.337
	0.321	0.348
Reference Range: 6020~6500K		

Bin	CIE X	CIE Y
65K-2	0.303	0.330
	0.305	0.321
	0.313	0.329
	0.312	0.339
Reference Range: 6500~7050K		

Bin	CIE X	CIE Y
65K-4	0.313	0.329
	0.314	0.319
	0.322	0.326
	0.321	0.337
Reference Range: 6020~6500K		

Bin	CIE X	CIE Y
65K-3	0.305	0.321
	0.307	0.311
	0.314	0.319
	0.313	0.329
Reference Range: 6500~7050K		

Neutral-White Bin Structure

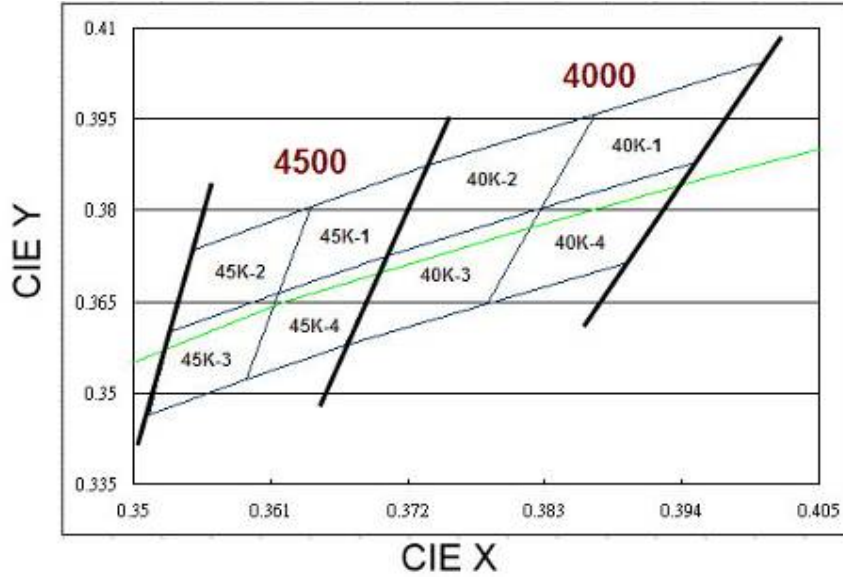

Neutral-White Bin Coordinates

4000K

Bin	CIE X	CIE Y
40K-1	0.387	0.396
	0.383	0.380
	0.395	0.388
	0.401	0.404
Reference Range: 3710~4000K		

Bin	CIE X	CIE Y
40K-2	0.374	0.387
	0.370	0.373
	0.383	0.380
	0.387	0.396
Reference Range: 4000~4260K		

Bin	CIE X	CIE Y
40K-4	0.383	0.380
	0.378	0.365
	0.390	0.372
	0.395	0.388
Reference Range: 3710~4000K		

Bin	CIE X	CIE Y
40K-3	0.370	0.373
	0.367	0.358
	0.378	0.365
	0.383	0.380
Reference Range: 4000~4260K		

4500K

Bin	CIE X	CIE Y
45K-1	0.364	0.381
	0.362	0.366
	0.370	0.373
	0.374	0.387
Reference Range: 4260~4500K		

Bin	CIE X	CIE Y
45K-2	0.355	0.374
	0.353	0.360
	0.362	0.366
	0.364	0.381
Reference Range: 4500~4745K		

Bin	CIE X	CIE Y
45K-4	0.362	0.366
	0.359	0.352
	0.367	0.358
	0.370	0.373
Reference Range: 4260~4500K		

Bin	CIE X	CIE Y
45K-3	0.353	0.360
	0.351	0.347
	0.359	0.352
	0.362	0.366
Reference Range: 4500~4745K		

Warm-White Bin Structure

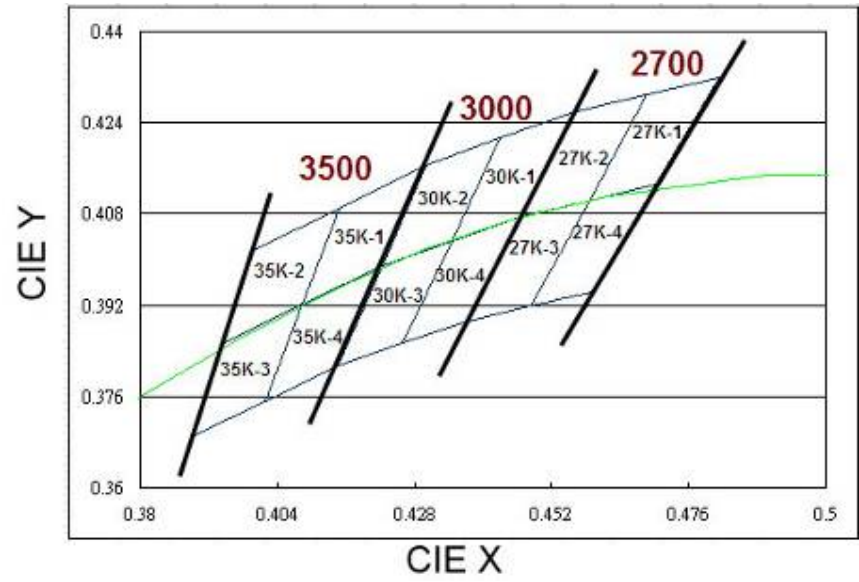

Warm-White Bin Coordinates

2700K

Bin	CIE X	CIE Y
27K-1	0.469	0.429
	0.459	0.410
	0.470	0.413
	0.481	0.432
Reference Range: 2580~2700K		

Bin	CIE X	CIE Y
27K-2	0.456	0.426
	0.447	0.408
	0.459	0.410
	0.469	0.429
Reference Range: 2700~2870K		

Bin	CIE X	CIE Y
27K-4	0.459	0.410
	0.448	0.392
	0.459	0.394
	0.470	0.413
Reference Range: 2580~2700K		

Bin	CIE X	CIE Y
27K-3	0.447	0.408
	0.437	0.389
	0.448	0.392
	0.459	0.410
Reference Range: 2700~2870K		

3000K

Bin	CIE X	CIE Y
30K-1	0.443	0.421
	0.435	0.403
	0.447	0.408
	0.456	0.426
Reference Range: 2870~3000K		

Bin	CIE X	CIE Y
30K-2	0.430	0.417
	0.422	0.399
	0.435	0.403
	0.443	0.421
Reference Range: 3000~3220K		

Bin	CIE X	CIE Y
30K-4	0.435	0.403
	0.426	0.385
	0.437	0.389
	0.447	0.408
Reference Range: 2870~3000K		

Bin	CIE X	CIE Y
30K-3	0.422	0.399
	0.415	0.381
	0.426	0.385
	0.435	0.403
Reference Range: 3000~3220K		

3500K

Bin	CIE X	CIE Y
35K-1	0.415	0.409
	0.408	0.392
	0.422	0.399
	0.430	0.417
Reference Range: 3220~3500K		

Bin	CIE X	CIE Y
35K-2	0.400	0.402
	0.394	0.385
	0.408	0.392
	0.415	0.409
Reference Range: 3500~3710K		

Bin	CIE X	CIE Y
35K-4	0.408	0.392
	0.402	0.375
	0.415	0.381
	0.422	0.399
Reference Range: 3220~3500K		

Bin	CIE X	CIE Y
35K-3	0.394	0.385
	0.389	0.369
	0.402	0.375
	0.408	0.392
Reference Range: 3500~3710K		

Forward Voltage Bins

Group Name	Bins
S	R2+R3
T	R2+R3+R4

Bin	Minimum Forward Voltage (V)	Maximum Forward Voltage (V)
R1	8.0	9.0
R2	9.0	10.0
R3	10.0	11.0
R4	11.0	12.0

Notes:

1. Forward voltage measurement tolerance: $\pm 0.1V$.
2. Forward voltage bins are defined at $I_f=1050mA$ operation.
3. Currently available Forward Voltage bins for White LEDs are highlighted and bolded.
4. Other Forward Voltage bins for White LEDs available upon request. Please contact your local Everlight sales office.

Optical Characteristics

Color	Part Number	Color temperature CCT			Typical Viewing Angle (degrees) $2\theta_{1/2}$
		Min.	Typ.	Max.	
		Cool-White	ELTS – XX2C6	4745K	
Neutral-White	ELTS – XX2N6	3710K	4260K	4745K	135
Warm-White	ELTS – XX2M6	2580K	3000K	3710K	135

Notes:

1. The test tolerance of Everlight is $\pm 5\%$ for CCT.
2. Viewing angle is the width of half the light output intensity in all directions of 180° .
3. All Cool-White, Neutral-White, Warm-White LEDs are made with Indium Gallium Nitride (InGaN).

Mechanical Dimension

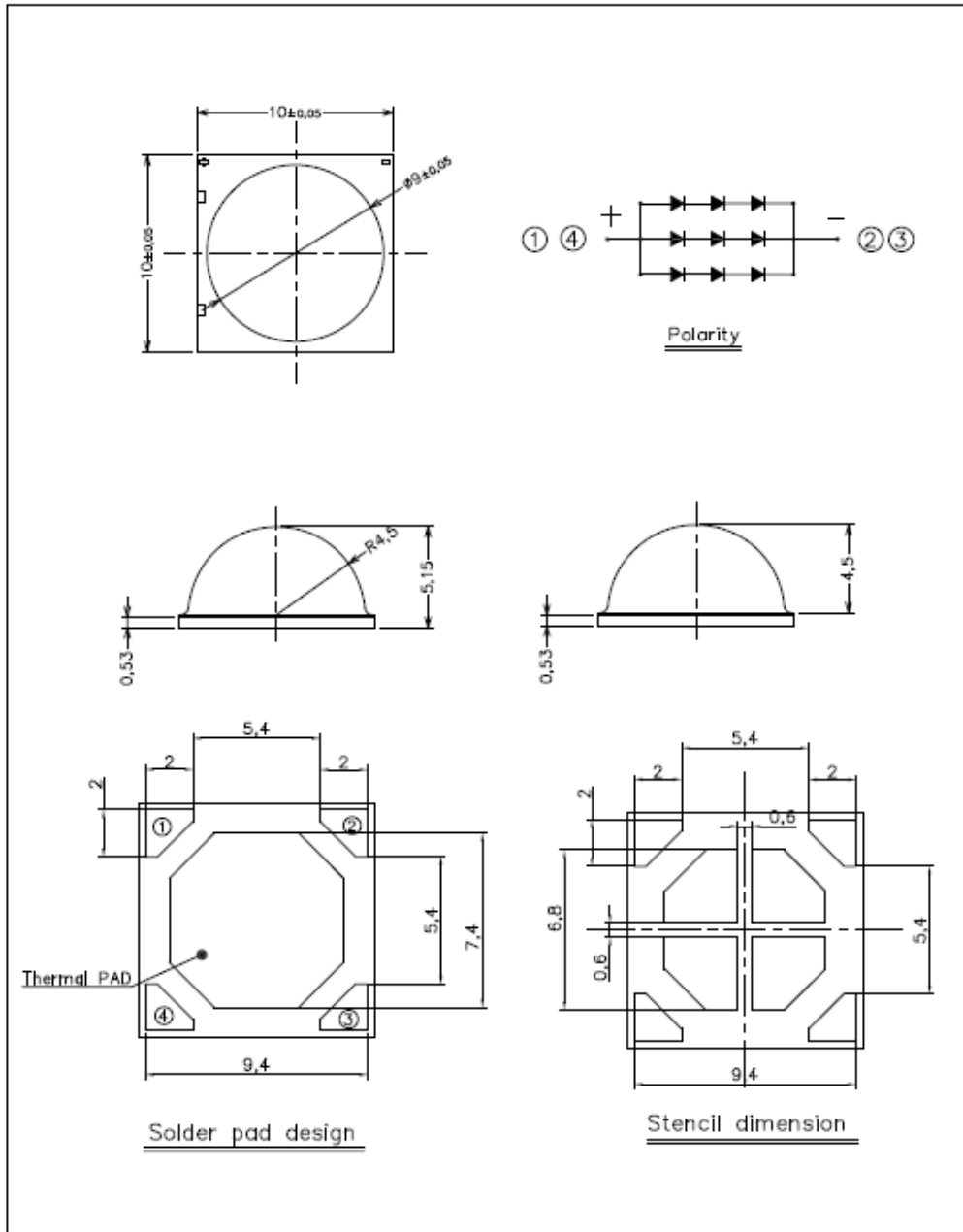

Notes:

1. Dimensions are in millimeters.
2. Tolerances unless mentioned are $\pm 0,1$ mm.
3. The thermal pad is electrically isolated from the Anode and Cathode contact pads.

Pad Configuration

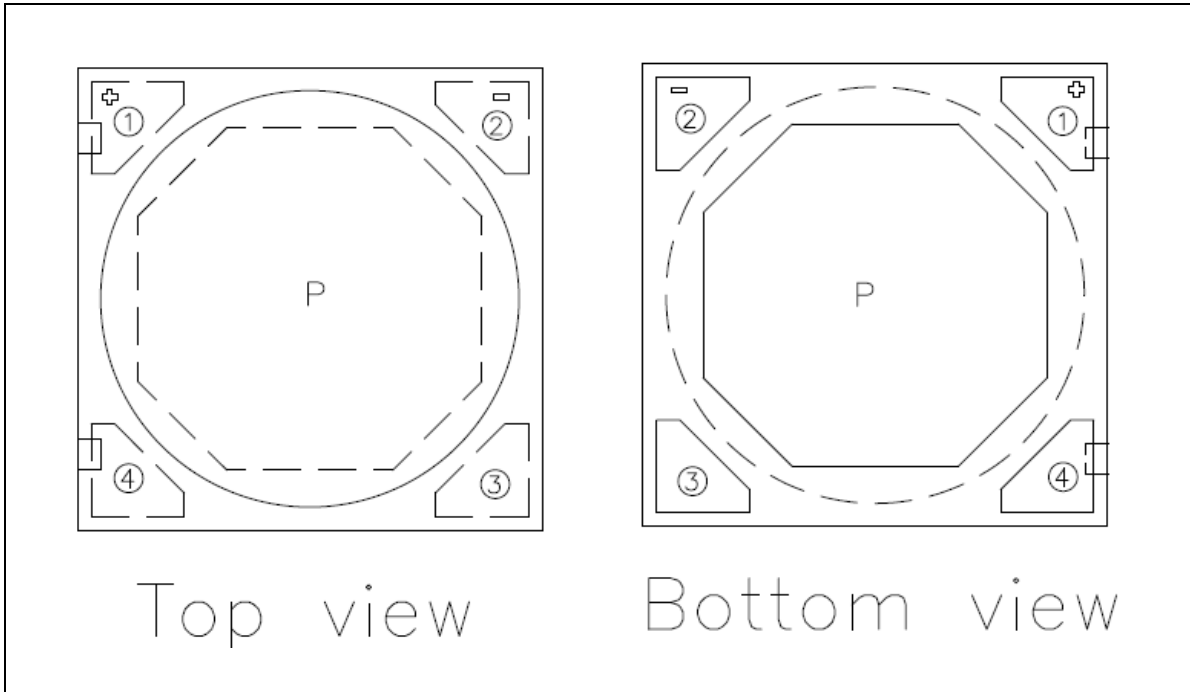

PAD	FUNCTION
1 and 4	ANODE
2 and 3	CATHODE
P	THERMAL PAD

Reflow Soldering Characteristics

For Reflow Process

- a. ELTS series are suitable for SMT processes.
- b. Curing of glue in oven must be according to standard operation flow processes.

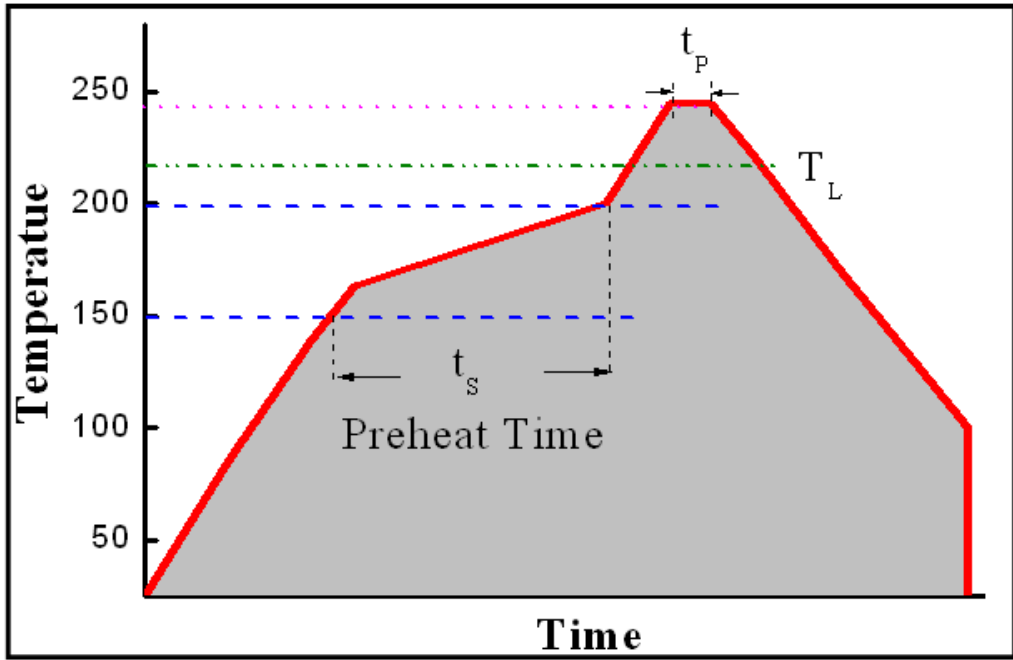

Profile Feature	Lead Free Assembly
Ramp-Up Rate	2-3 °C/S
Preheat Temperature	150-200 °C
Preheat Time (ts)	60-120 S
Liquid Temperature (TL)	217 °C
Time maintained above TL	60-90 S
Peak Temperature (Tp)	240±5 °C
Peak Time (tp)	Max 20 S
Ramp-Down Rate	3-5 °C/S

- c. Reflow soldering should not be done more than twice.
- d. In soldering process, stress on the LEDs during heating should be avoided.
- e. After soldering, do not bend the circuit board.

Wavelength Characteristics

For Cool-White, @ Thermal Pad Temperature = 25°C

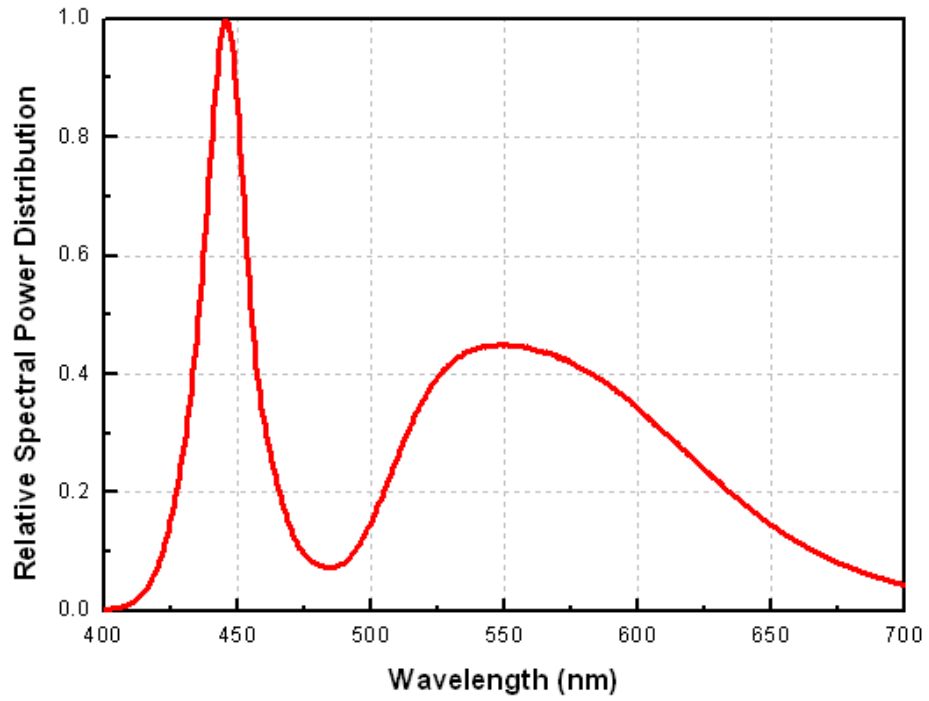

For Neutral-White, @ Thermal Pad Temperature = 25°C

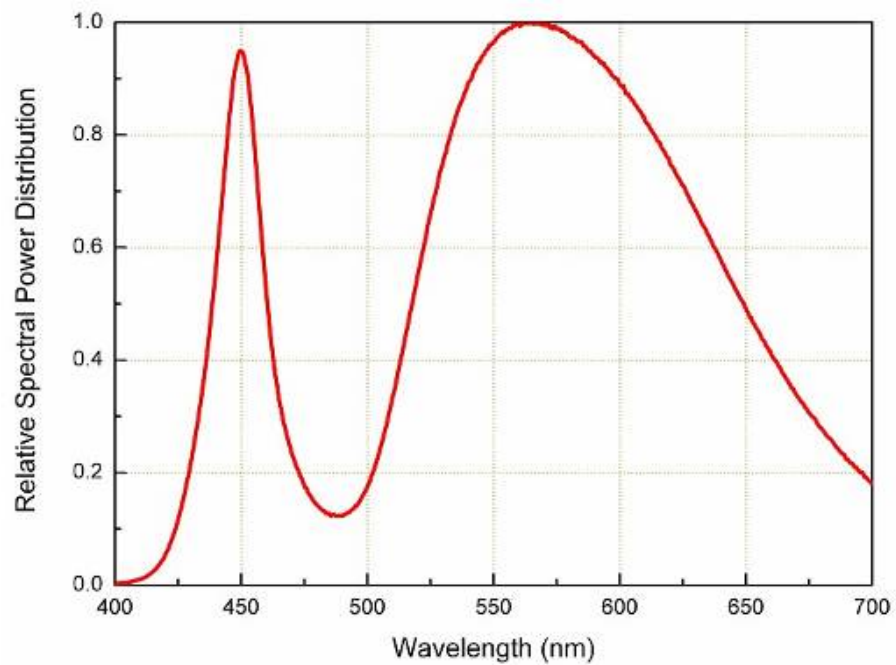

For Warm-White, @ Thermal Pad Temperature = 25°C

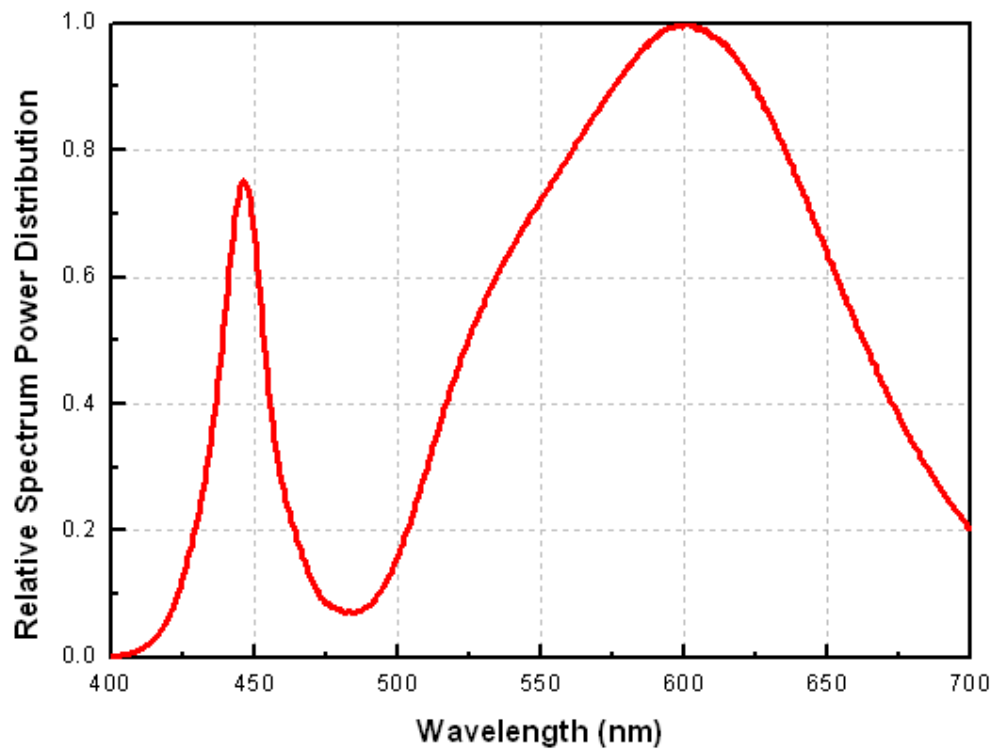

Typical Light Output Characteristic vs. Thermal Pad Temperature

Cool-White, Neutral-White, Warm-White, for 1050mA Drive Current

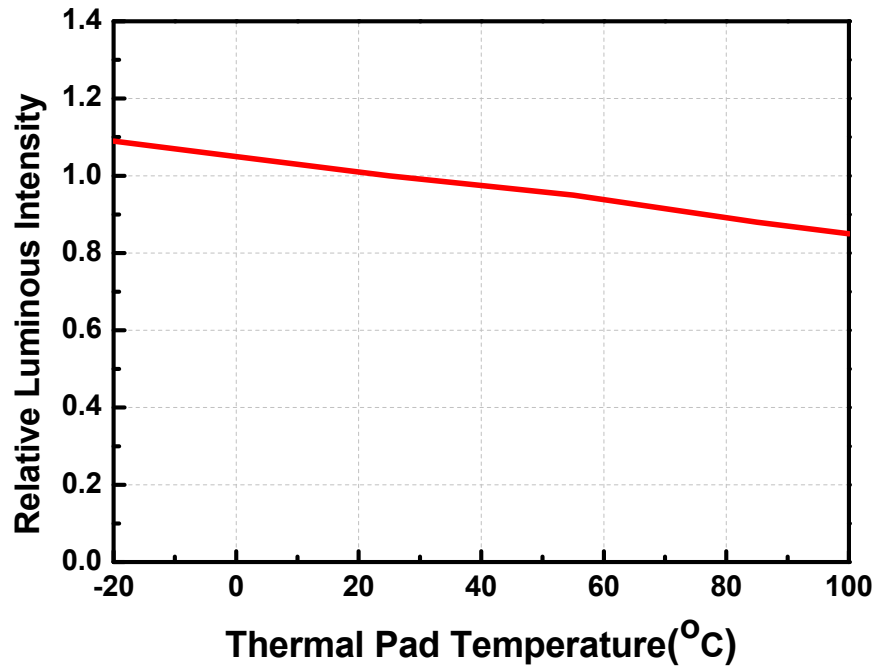

Typical Electrical Characteristics

For Cool-White, Neutral-White and Warm-White
@ Thermal Pad Temperature = 25°C

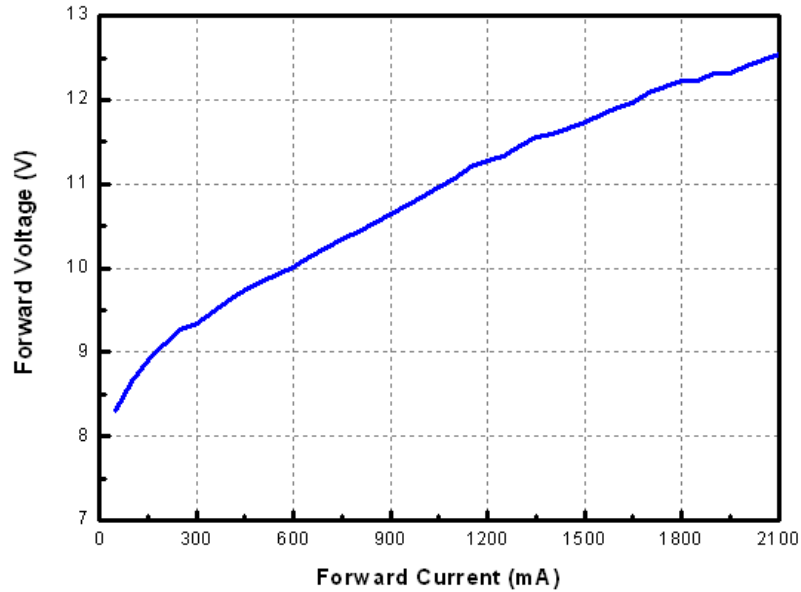

Typical Relative Luminous Flux vs. Forward Current

For Cool-White, Neutral-White and Warm-White
@ Thermal Pad Temperature = 25°C

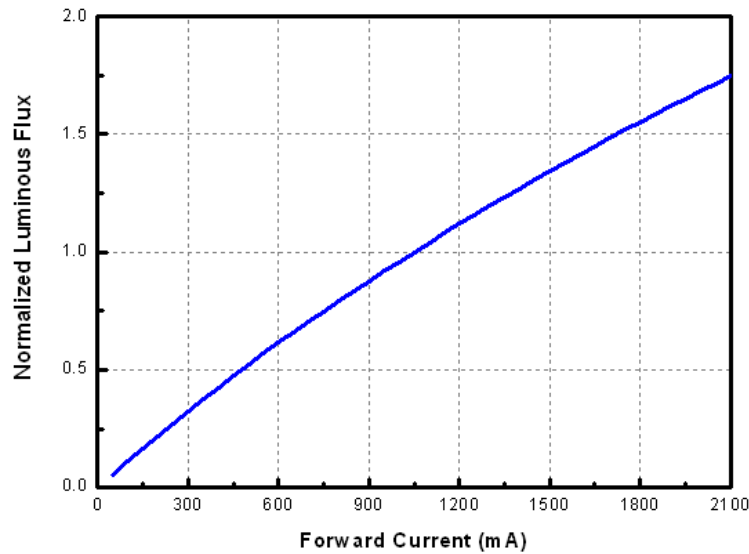

Typical Wavelength & CCT Shift Characteristics vs. Forward Current

For Cool-White @ Thermal Pad Temperature = 25°C

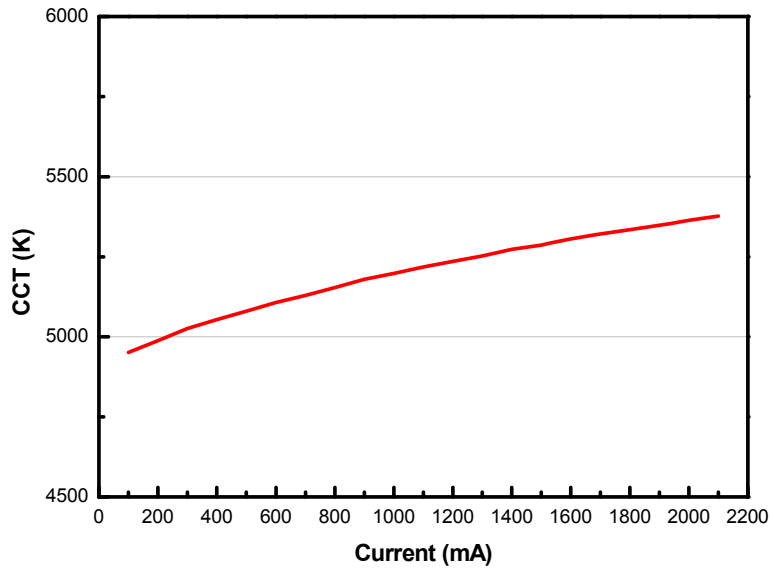

For Warm-White @ Thermal Pad Temperature = 25°C

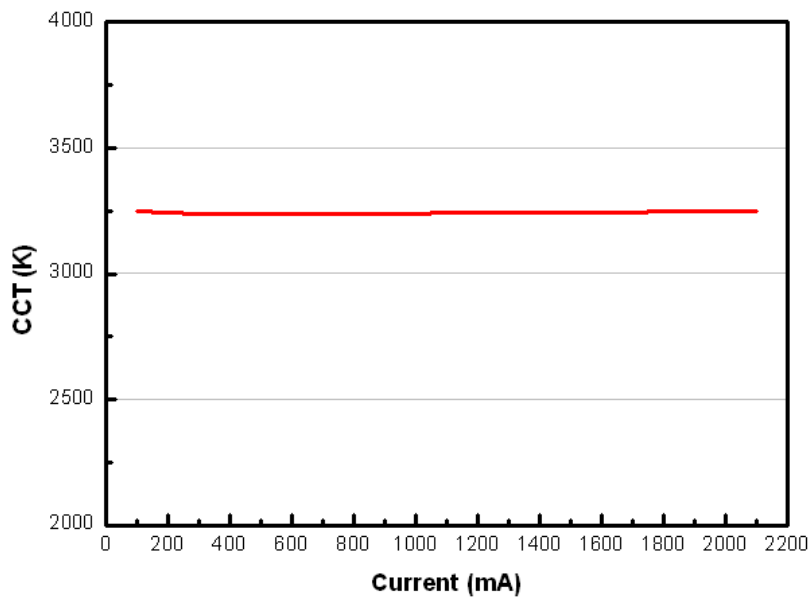

Current Derating Curves

Current Derating Curve for 1050mA Drive Current Cool-White, Neutral-White and Warm-White

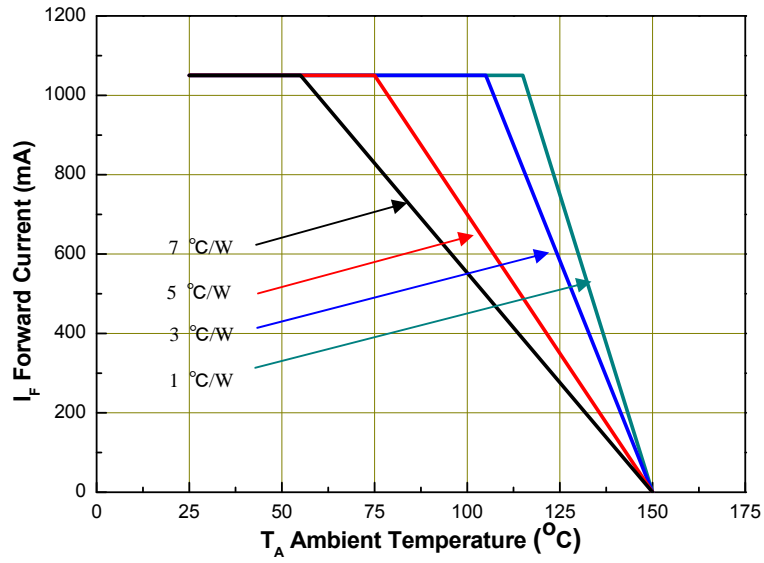

Typical Radiation Patterns

Typical Spatial Radiation Pattern for Cool-White, Neutral-White and Warm-White

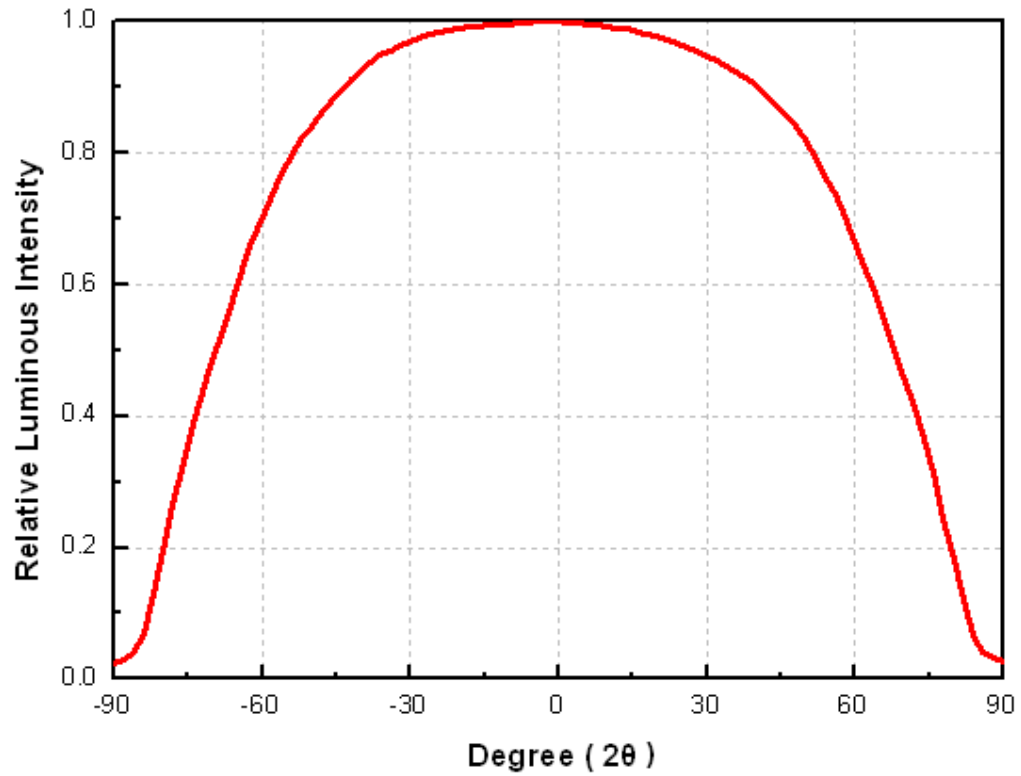

Notes:

1. $2\theta_{1/2}$ is the off axis angle from lamp centerline where the luminous intensity is 1/2 of the peak value.
2. Viewing angle tolerance is $\pm 5^\circ$

Typical Polar Radiation Pattern for Cool-White, Neutral-White and Warm-White

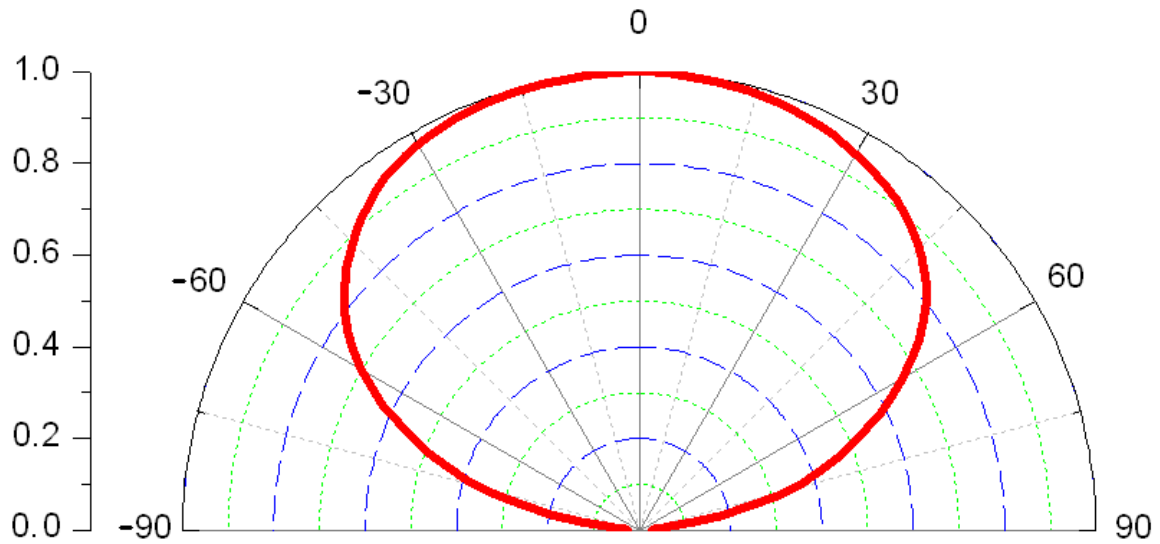

Typical Difference of CIE X of Cool-White versus Angle

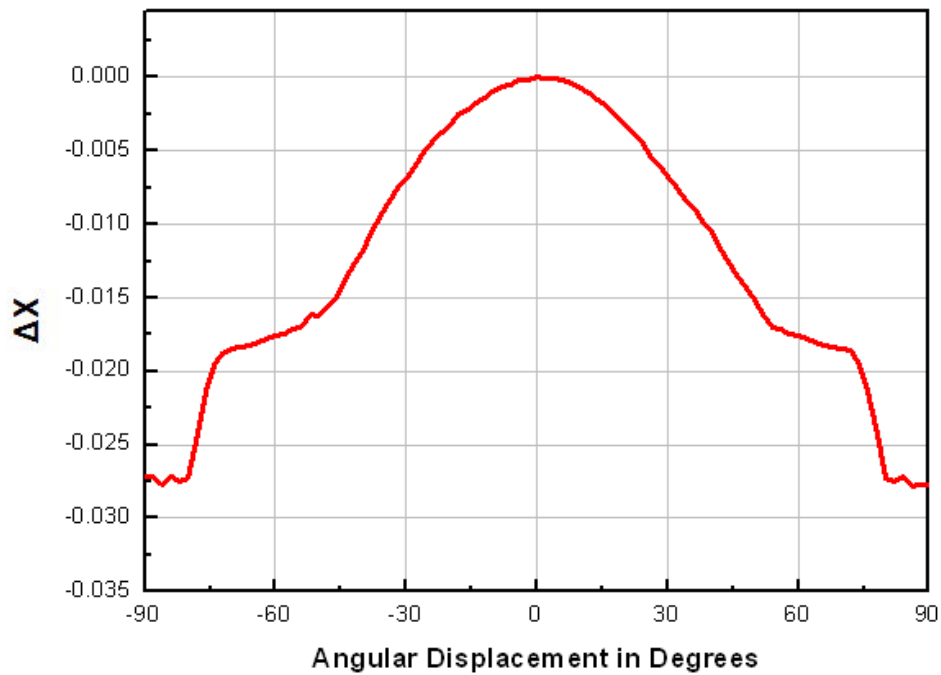

Typical Difference of CIE Y of Cool-White versus Angle

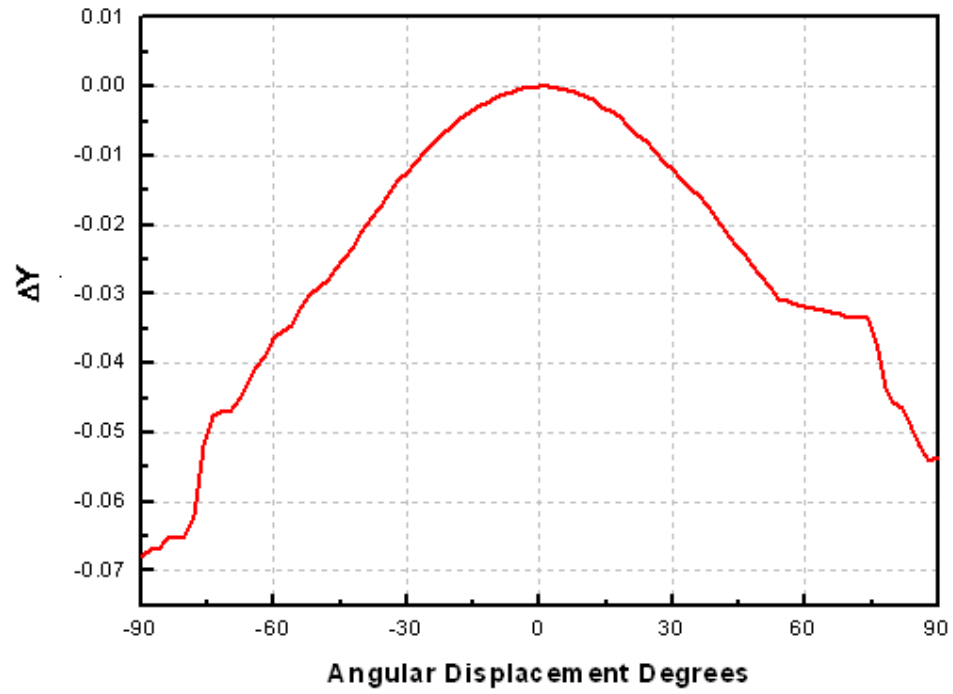

Emitter Tape Packaging

Carrier Reel Information: Loaded quantity 100 PCS per reel

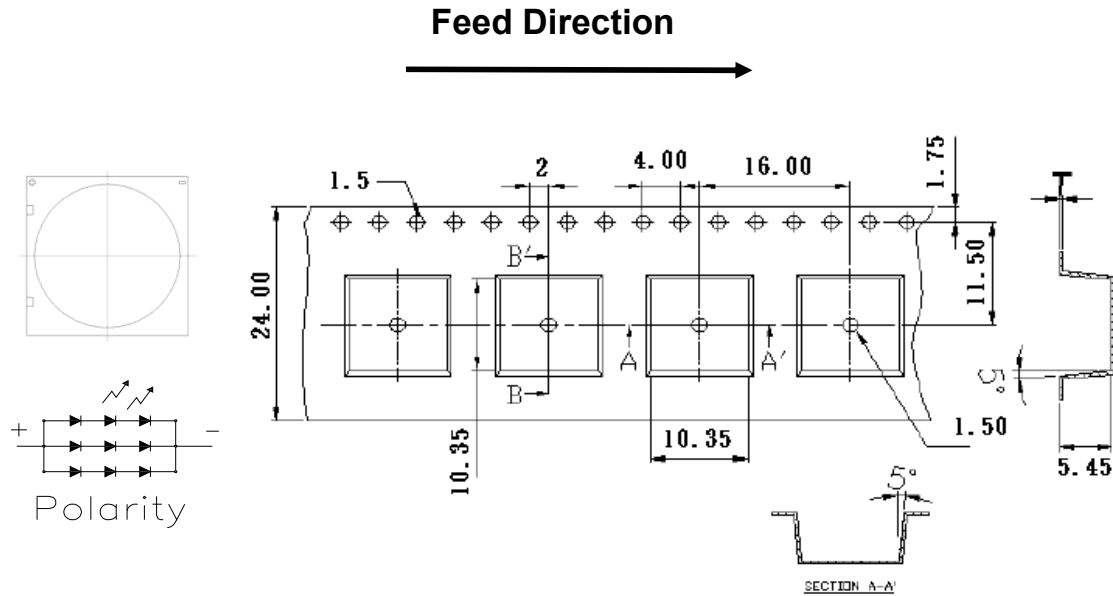

Notes:

1. Dimensions are in millimeters.
2. Tolerances for fixed dimensions are ± 0.1 mm.

Moisture Resistant Packaging

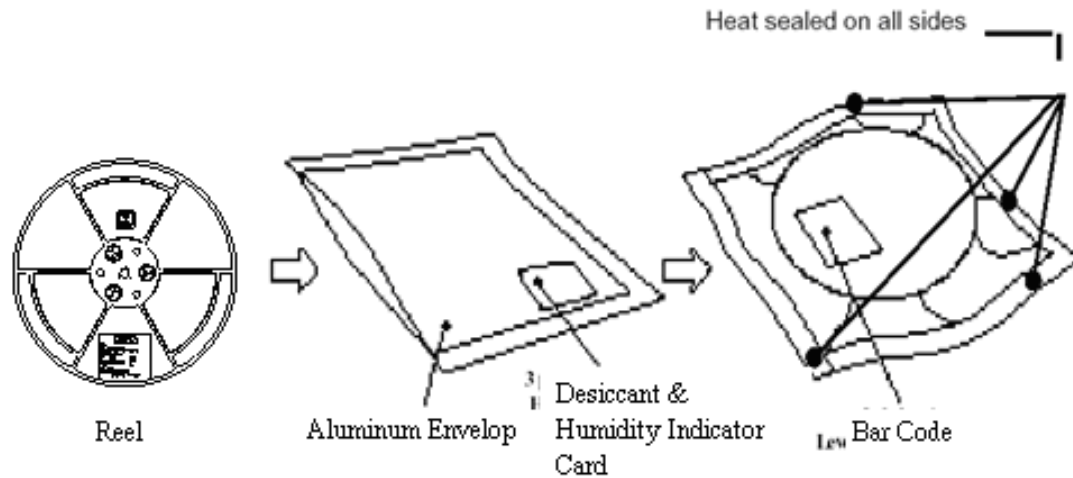

Emitter Reel Packaging

Reel Dimensions

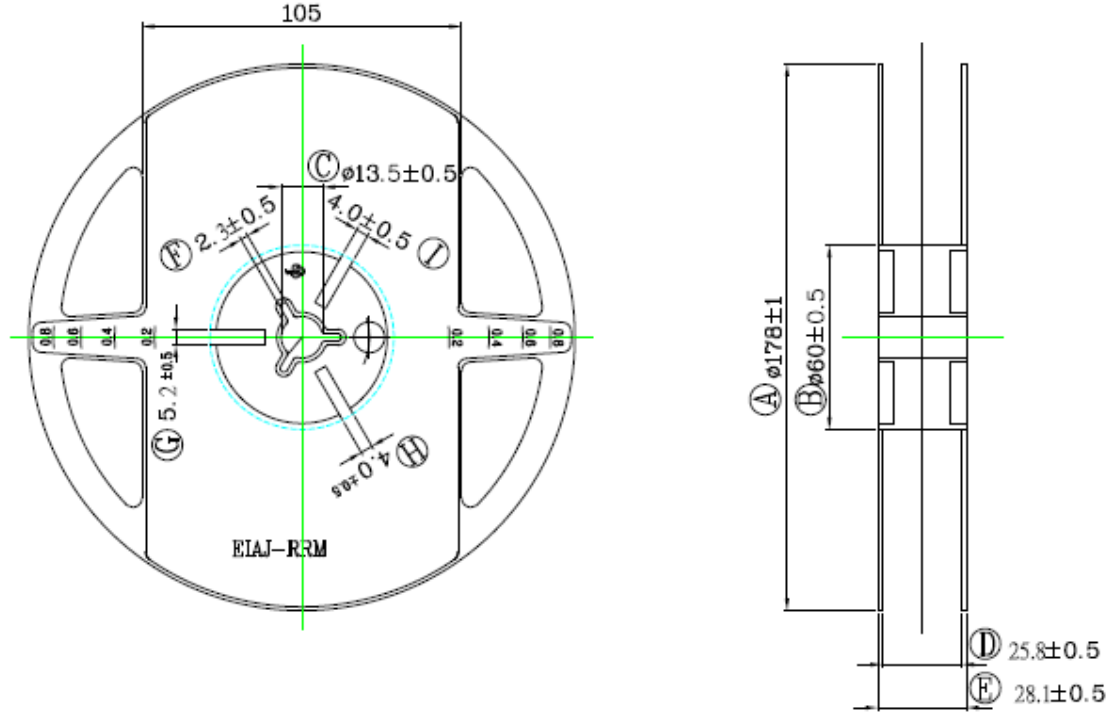

Notes:

1. Dimensions are in millimeters.
2. Tolerances unless mentioned are ± 0.1 mm.

Product Labeling

Label Explanation

- CPN: Customer Specification (when required)
- P/N : Everlight Production Number
- QTY: Packing Quantity
- CAT: Luminous Flux (Brightness) Bin
- HUE: Color Bin
- REF: Forward Voltage Bin
- LOT No: Lot Number
- MADE IN TAIWAN: Production Place



Revision History

Current version: **2010/08/27**

Previous version: N/A

Device No: DHE-0001158

Rev. Ver. 4

Page	Subjects (major change in previous version)	Date of change
14	In the mechanical dimension, the polarity diagram is changed.	2010/06/04
15	In the pad configuration, the polarity is changed.	2010/06/04
5~6	The part number and order code are changed.	2010/06/18
7	In the product binning, the luminous flux bin is changed.	2010/06/18
3	In the product nomenclature, the designation is changed.	2010/08/27
4	In the absolute maximum ratings, the parameter is changed.	2010/08/27