

# 9 LED Light Panels from Inspired LED



Light Panels are ideally suited for under the counter task lighting applications, kitchen lighting, jewelry lighting, decorative lighting and reading lighting. Light Panels are brushed aluminum in color to blend with today's kitchen styles. Components are sold as a kit and can be also purchased individually to create a system of up to Ten Light Panels.

## Features

- ✗ Low Cost Modular Design
- ✗ Both Warm and Cool Color Light Options
- ✗ Long Life 80,000HRs
- ✗ Easy Installation
- ✗ Highly Efficient PS
- ✗ Low Energy Consumption
- ✗ UV or IR free

## Interconnection

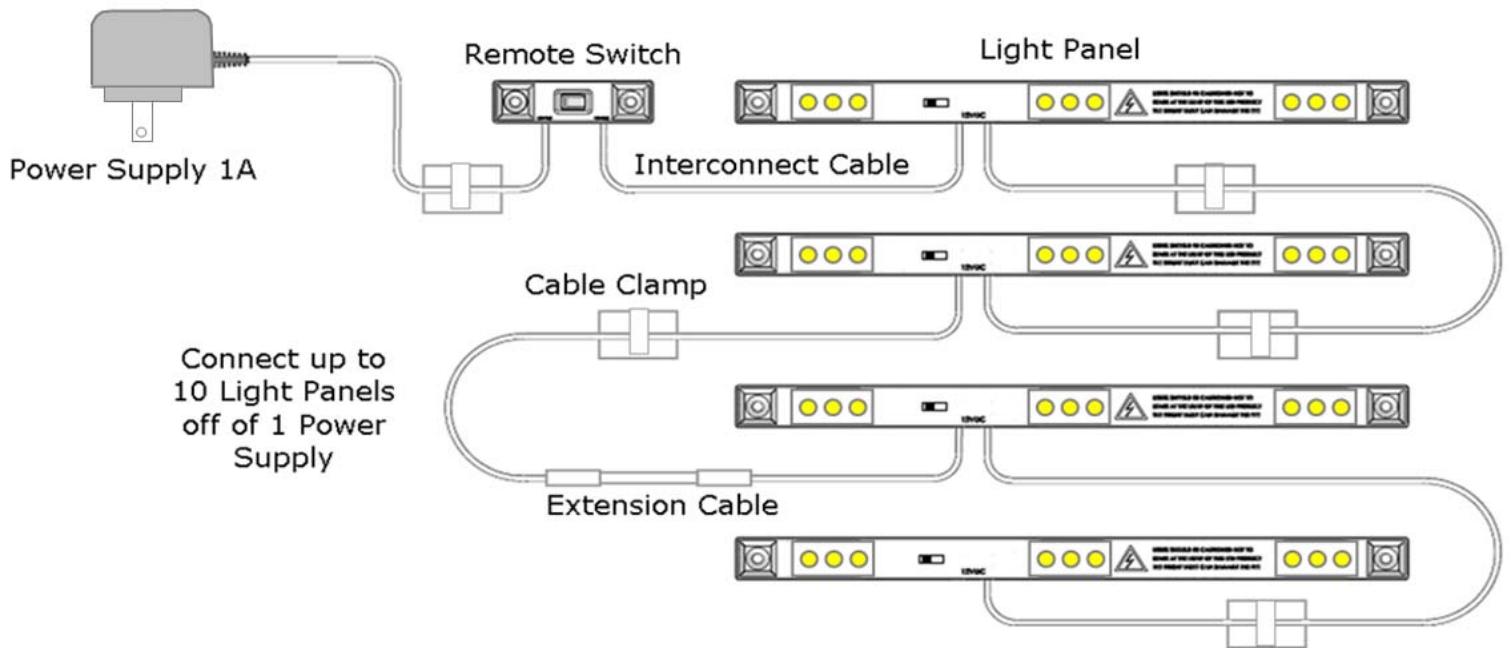

## Specifications

- ✗ Power Supply – 1 ¼" x 1 ¼" x 2" body with 5' cable, UL Listed 100 - 120VAC in 12VDC / 1Amp
- ✗ 1 Watt Light Panel – 10 ½" (L) x ¾" (W) x 3/8" (H). 12VDC, 9 LEDs, Screw or Adhesive Mounting Warm White Color Temp. 3200K nm 23 lm, Cool White Color Temp. 6500K nm 38 lm
- ✗ Remote Switch – 2 ½" (L) x ¾" (W) x ½" (H) Screw or Adhesive Mounting
- ✗ Interconnect Cable – 4", 3', 4', 6' & 12' lengths available.
- ✗ Extension Cable – 5" Cable that connects multiple Interconnect cables together to increase length.
- ✗ Cable Clamp – 1 ¼" square adhesive backed pads to hold Cables in place.