

UNCONTROLLED DOCUMENT

PART NUMBER		REV.
SSL-LX3044SRC/X		C
REV.	E.C.N. NUMBER AND REVISION COMMENTS	DATE
A	UPDATED SPECS.	11.28.94
B	E.C.N. #10584.	1.17.00
C	E.C.N. #10BRDR. & REDRAWN IN 3D.	4.10.01

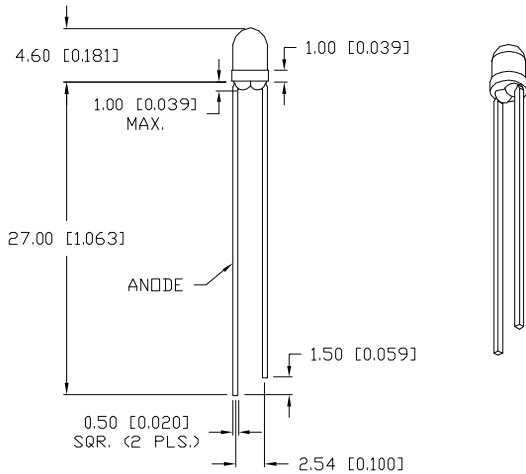
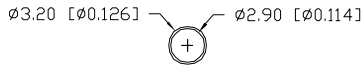

NOTES:

1. PART NUMBER SUFFIX /X REPRESENTS AXIAL INTENSITY.

ELECTRO-OPTICAL CHARACTERISTICS  $T_A=25^{\circ}\text{C}$   $I_f=20\text{mA}$

PARAMETER	MIN	TYP	MAX	UNITS	TEST COND
PEAK WAVELENGTH		660		nm	
FORWARD VOLTAGE		1.8	2.3	$V_f$	
REVERSE VOLTAGE	4.0			$V_r$	$I_r=100\mu\text{A}$
AXIAL INTENSITY /B	250	300		mcd	$I_f=20\text{mA}$
/C	360	430		mcd	$I_f=20\text{mA}$
/D	500	600		mcd	$I_f=20\text{mA}$
/E	700	850		mcd	$I_f=20\text{mA}$
/F	1000	1100		mcd	$I_f=20\text{mA}$
/G	1200	1300		mcd	$I_f=20\text{mA}$
/H	1400	1700		mcd	$I_f=20\text{mA}$
/J	1800	2300		mcd	$I_f=20\text{mA}$
VIEWING ANGLE		30			$2x$ theta
EMITTED COLOR:	RED				
EPOXY LENS FINISH:	WATER CLEAR				

LIMITS OF SAFE OPERATION AT  $25^{\circ}\text{C}$

PARAMETER	MAX	UNITS
PEAK FORWARD CURRENT*	150	mA
STEADY CURRENT	30	mA
POWER DISSIPATION	100	mW
DERATE FROM $25^{\circ}\text{C}$	-1.6	mW/ $^{\circ}\text{C}$
OPERATING, STORAGE TEMP.	-40 TO +85	$^{\circ}\text{C}$
SOLDERING TEMP.	+260	$^{\circ}\text{C}$
2.0mm FROM BODY		3 SEC. MAX

\*  $t < 10\mu\text{s}$

REPLACES PART #: SSL-LX3044SRC(/B-/G)

\*UNLESS OTHERWISE SPECIFIED TOLERANCES PER DECIMAL PRECISION ARE: X=±1 (±0.039), XX=±0.5 (±0.020), XXX=±0.25 (±0.010), XXXX=±0.127 (±0.005). LEAD SIZE=±0.05 (±0.002), LEAD LENGTH=±0.75 (±0.030). MIN= +DECIMAL PRECISION MAX= +0.00 -DECIMAL PRECISION

UNCONTROLLED DOCUMENT

REV. C	PART NUMBER SSL-LX3044SRC/X	<p>CONFIDENTIAL INFORMATION</p> <p>THE INFORMATION CONTAINED IN THIS DOCUMENT IS THE PROPERTY OF LUMEX INC. EXCEPT AS SPECIFICALLY AUTHORIZED IN WRITING BY LUMEX INC., THE HOLDER OF THIS DOCUMENT SHALL KEEP ALL INFORMATION CONTAINED HEREIN CONFIDENTIAL AND SHALL PROTECT SAME IN WHOLE OR IN PART FROM DISCLOSURE AND DISSEMINATION TO ALL THIRD PARTIES.</p> <p>RELIABILITY NOTE</p> <p>OUR MANY YEARS OF EXPERIENCE DATA ACCUMULATION INDICATE THAT SOLDER HEAT IS A MAJOR CAUSE OF EARLY AND FUTURE FAILURE. PLEASE PAY ATTENTION TO YOUR SOLDERING PROCESS.</p>	<p>290 E. HELEN ROAD PALATINE, IL 60067-6976 PHONE: +1.847.359.2790 US WEB: www.lumex.com TW WEB: www.lumex.com.tw</p>
T-3mm (T-1) 660nm SUPER RED LED, WATER CLEAR LENS.		<p>DRAWN BY: BC</p> <p>CHECKED BY:</p> <p>APPROVED BY:</p>	<p>DATE: 1.17.00 PAGE: 1 OF 1 SCALE: N/A</p>