

DATE	REVISIONS	REV
2-2-96	E.C.N. #1012. & #10113./	A
3-10-98	E.C.N. #10BRDR. & #10421. & REDRAWN./	B

DRAWING NUMBER	REV
SSL-LX100133GD	B

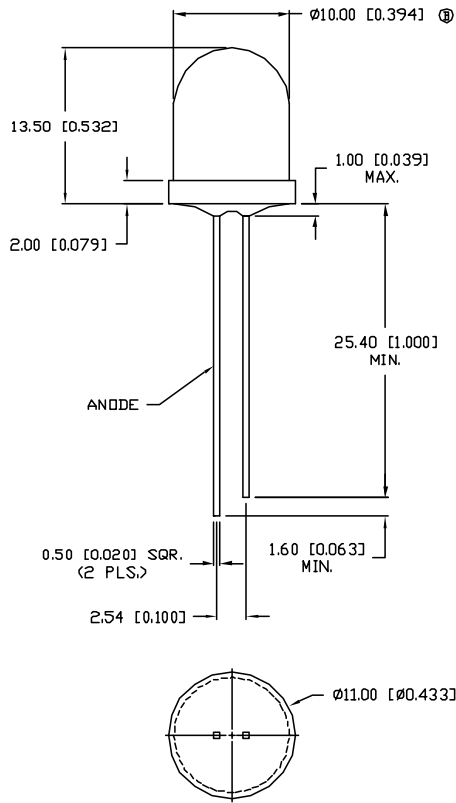

UNLESS OTHERWISE SPECIFIED TOLERANCE IS $\pm 0.25\text{mm}$ ($\pm 0.010''$)

ELECTRO-OPTICAL CHARACTERISTICS $T_A = 25^\circ\text{C}$ $I_f = 20\text{mA}$

PARAMETER	MIN	TYP	MAX	UNITS	TEST COND
PEAK WAVELENGTH		565 (GREEN)		nm	
FORWARD VOLTAGE		2.2	2.6	V_f	
REVERSE VOLTAGE	5.0			V_r	$I_r = 100\mu\text{A}$
AXIAL INTENSITY		30		mcd	$I_f = 20\text{mA}$
VIEWING ANGLE		60		$2 \times \text{theta}$	
EMITTED COLOR:	GREEN				
EPDXY LENS FINISH:	GREEN DIFFUSED				

LIMITS OF SAFE OPERATION AT 25°C

PARAMETER	MAX	UNITS
PEAK FORWARD CURRENT*	150	mA
STEADY CURRENT	25	mA
POWER DISSIPATION	105	mW
DERATE FROM 25°C	-1.2	mW/ $^\circ\text{C}$
OPERATING, STORAGE TEMP.	-40 TO +85	$^\circ\text{C}$
SOLDERING TEMP.	+260	$^\circ\text{C}$
2.0mm FROM BODY		3 SEC. MAX

* $t < 10\mu\text{s}$

RELIABILITY NOTE

OUR MANY YEARS OF EXPERIENCE DATA ACCUMULATION INDICATE THAT SOLDER HEAT IS A MAJOR CAUSE OF EARLY AND FUTURE FAILURE. PLEASE PAY ATTENTION TO YOUR SOLDERING PROCESS.

LUMEX INCORPORATED		290 E. HELLEN ROAD PALATINE, ILLINOIS 60067 (847) 359-2790	
<small>CONFIDENTIAL INFORMATION THE INFORMATION CONTAINED IN THIS DOCUMENT IS THE PROPERTY OF LUMEX INCORPORATED. EXCEPT AS SPECIFICALLY AUTHORIZED IN WRITING BY LUMEX INCORPORATED, THE HOLDER OF THIS DOCUMENT SHALL KEEP ALL INFORMATION CONTAINED HEREIN CONFIDENTIAL AND SHALL PROTECT SAME IN WHOLE OR IN PART FROM DISCLOSURE AND DISSEMINATION TO ALL THIRD PARTIES.</small>			
DATE: 7-14-93	DWN:	CHK'D:	APPD:
SCALE: N/A			
T-3 1/8mm (T-10) LED, GREEN, DIFFUSED LENS.			
PAGE 1 OF 1	DRAWING NUMBER SSL-LX100133GD		REV B