



MODEL NO: 15-21VGC/TR8

Device Number : DSE-151-047 REV. 1.2

1206 Package Chip LEDs

ECN : _____ Page: 1/8

Features :

- Package in 8mm tape on 7" diameter reel.
- Compatible with automatic placement equipment.
- Compatible with infrared and vapor phase reflow solder process.
- Mono-color type.

Descriptions :

- The 15-21 SMD Taping is much smaller than leaded components, thus enable smaller board size, higher packing density, reduced storage space and finally smaller equipment to be obtained.
- Besides, lightweight makes them ideal for miniature application, etc.

Applications :

- Automotive: backlighting in dashboard and switch.
- Telecommunication: indicator and backlighting in telephone and fax.
- Flat backlight for LCD, switch and symbol.
- General use.

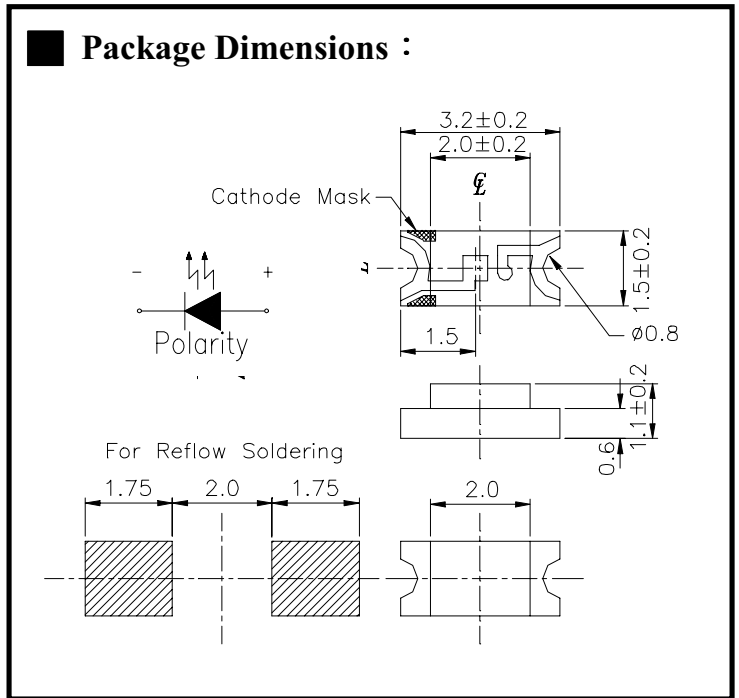

Notes :

Tolerances Unless Dimension ±
0.1mm
Angle± 0.5°
Unit = mm

PART NO	CHIP		Lens Color
	Material	Emitted Color	
15-21VGC/TR8	GaP	Green	Water Clear

Office: NO. 25, Lane 76, Sec.3, Chung Yang Rd., Tucheng 236, Taipei, Taiwan, R.O.C.

TEL: 886-2-2267-2000, 2267-9936

FAX: 886-2-2267-6244, 2267-6189, 2267-6306

http://www.everlight.com



EVERLIGHT ELECTRONICS CO., LTD.

MODEL NO: 15-21VGC/TR8

Device Number : DSE-151-047 REV. 1.2

1206 Package Chip LEDs

ECN : _____ Page: 2/8

■ **Package Dimensions :**

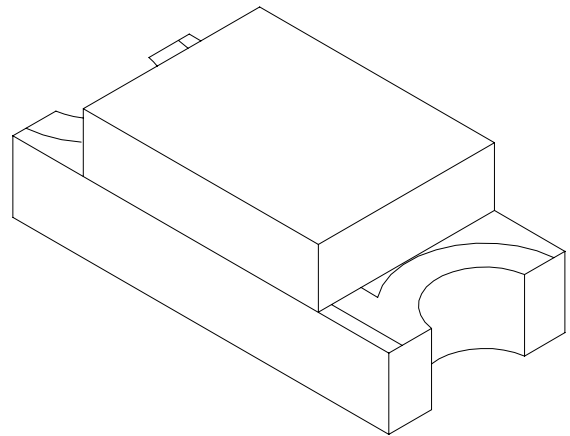
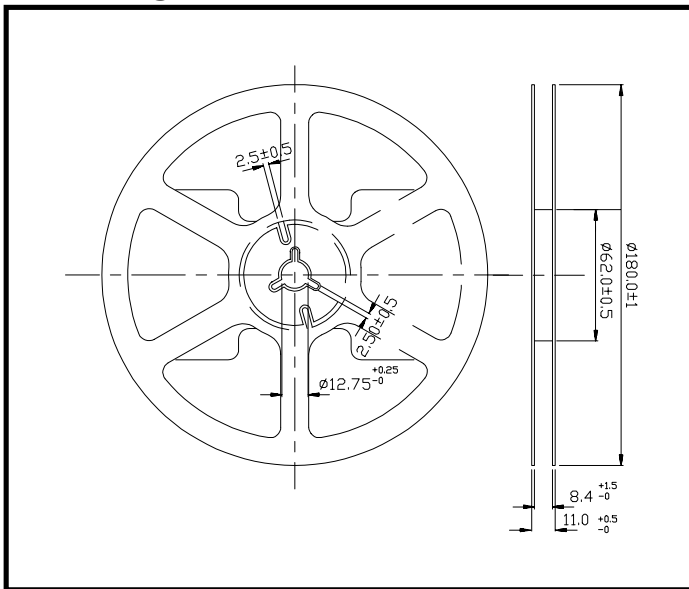

■ **Loaded quantity per reel 2000 pcs/reel :**

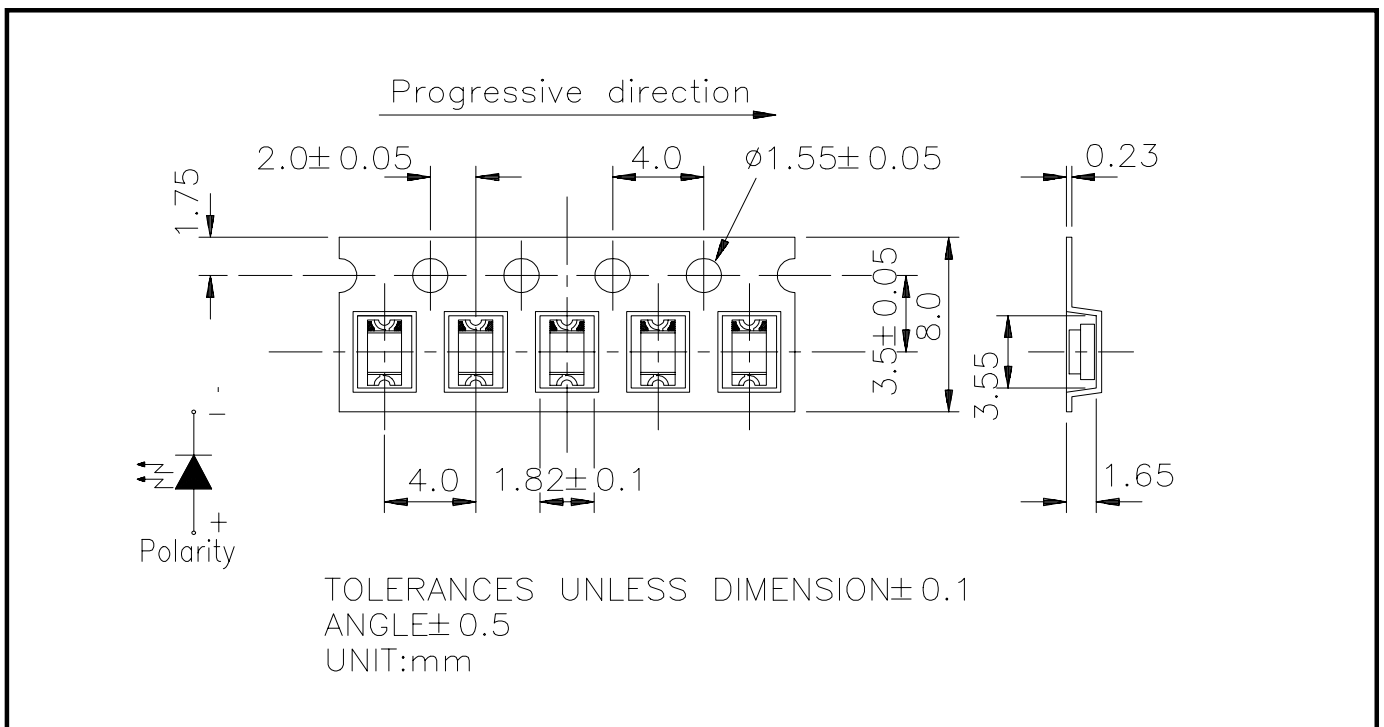

MODEL NO: 15-21VGC/TR8Device Number : DSE-151-047 REV. 1.2**1206 Package Chip LEDs**ECN : _____ Page: 3/8**■ Absolute Maximum Ratings at Ta = 25°C**

Parameter	Symbol	Rating	Unit
Reverse Voltage	Vr	5	V
Forward Current	If	30	mA
Operating Temperature	Topr	-40 ~ +85	°C
Storage Temperature	Tstg	-40~ +90	°C
Soldering Temperature	Tsol	260 (for 5 second)	°C
Power Dissipation	Pd	100	mW
Peak Forward Current(Duty 1/10 @ 1KHZ)	If(Peak)	160	mA

■ Electronic Optical Characteristics :

Parameter	Symbol	Min.	Typ.	Max.	Unit	Condition
Luminous intensity	Iv	7.5	13	-----	mcd	If=20mA
Viewing Angle	2θ 1/2	-----	140	-----	deg	If=20mA
Peak Wavelength	λ p	-----	570	-----	nm	If=20mA
Dominant Wavelength	λ d	-----	571	-----	nm	If=20mA
Spectrum Radiation Bandwidth	△ λ	-----	45	-----	nm	If=20mA
Forward Voltage	Vf	1.7	2.1	2.4	V	If=20mA
Reverse Current	Ir	-----	-----	10	μ A	Vr=5V



MODEL NO: 15-21VGC/TR8

Device Number : DSE-151-047 REV. 1.2

1206 Package Chip LEDs

ECN : Page: 4/8

Typical Electro-Optical Characteristic Curves

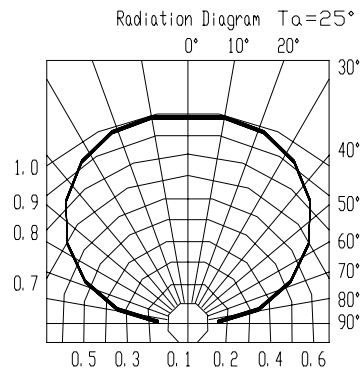
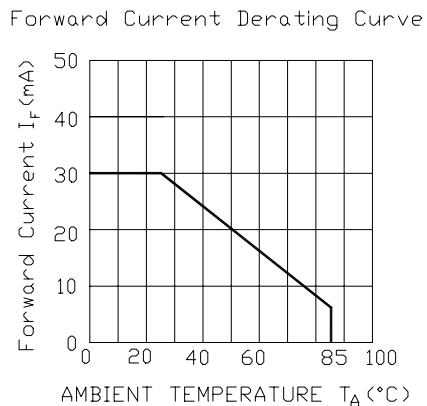
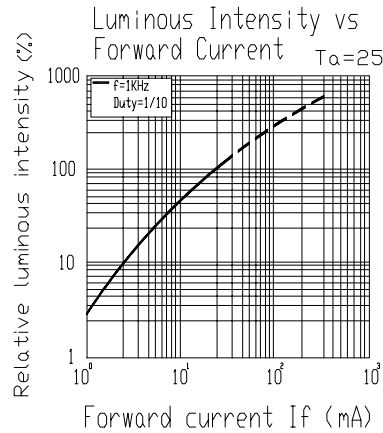
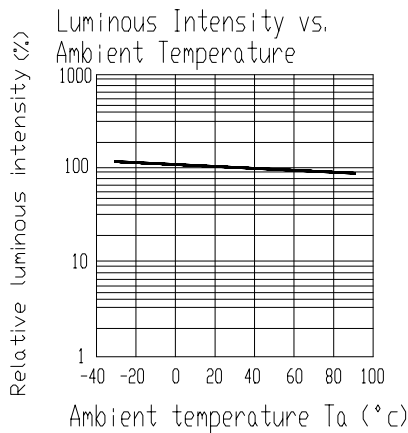
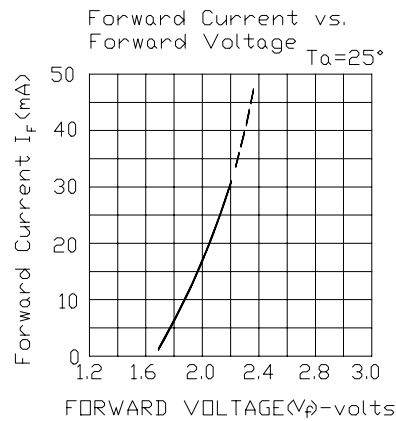
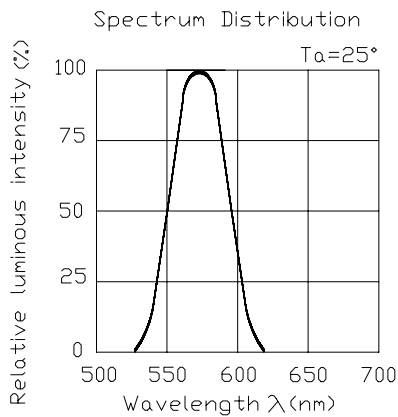



MODEL NO: 15-21VGC/TR8

Device Number : DSE-151-047 REV. 1.2

1206 Package Chip LEDs

ECN : Page: 6/8

■ Test Circuit

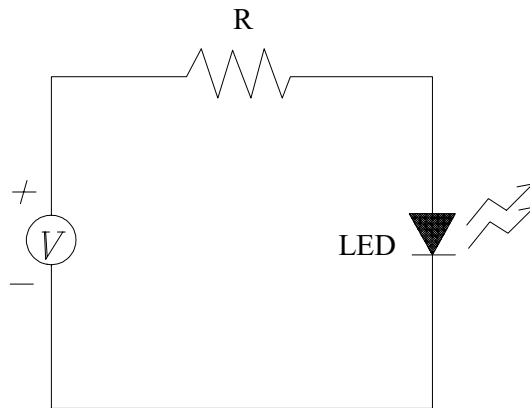

■ Precautions For Use

1. Over-current-proof

Customer must apply resistors for protection , otherwise slight voltage shift will cause big current change (Burn out will happen).

2. Storage time

2.1 The operation of temperature and R.H. are : $5^{\circ}\text{C}\sim 35^{\circ}\text{C}$, R.H.60%.

2.2 Once the package is opened, the products should be used within a week.

Otherwise, they should be keeping in a dampproof box with desiccants.

Considering the tape life , we suggest our customers to use our products within a year(from production date).

2.3 If opened more than one week in an atmosphere $5^{\circ}\text{C}\sim 35^{\circ}\text{C}$, R.H.60%, they should be treated at $60^{\circ}\text{C}\pm 5^{\circ}\text{C}$ for 15hrs.

2.4 When you discover that the desiccant in the package has a pink color (Normal = blue) , you should treat them in the same conditions as 2.3.

MODEL NO: 15-21VGC/TR8

Device Number : DSE-151-047 REV. 1.2

1206 Package Chip LEDs

ECN : _____ Page: 7/8

■ **Soldering heat reliability (DIP)**

Please refer to the following figure :

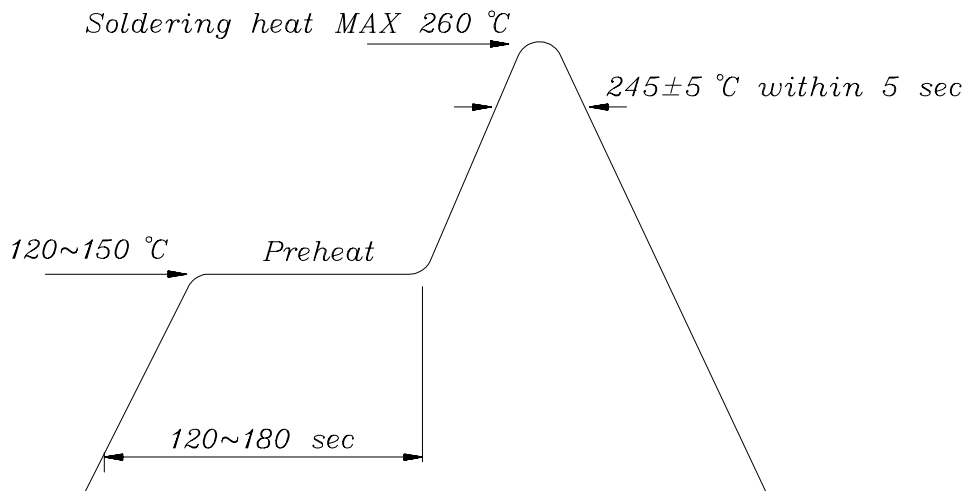

■ **Soldering Iron**

Basic spec is ≤ 5 sec when 260°C . If temperature is higher, time should be shorter ($+10^{\circ}\text{C} \rightarrow -1\text{sec}$). Power dissipation of iron should be smaller than 15 W , and temperature should be controllable. Surface temperature of the device should be under 230°C .

■ **Rework**

1. Customer must finish rework within 5 sec under 260°C .
2. The head of iron can not touch copper foil.
3. Twin-head type is preferred.

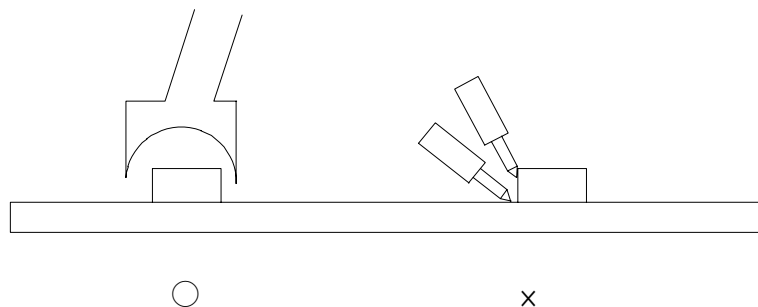



MODEL NO: 15-21VGC/TR8

Device Number : DSE-151-047 REV. 1.2

1206 Package Chip LEDs

ECN : Page: 8/8

■ Reflow Temp / Time :

