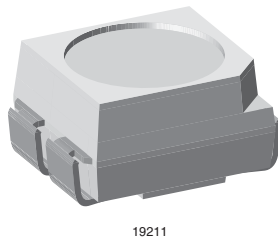


## Bicolor SMD LED PLCC-4



19211

### DESCRIPTION

These devices have been designed to meet the increasing demand for surface mounting technology.

The package of the VLMRY3420 is the PLCC-4.

It consists of a lead frame which is embedded in a white thermoplast. The reflector inside this package is filled up with clear epoxy.

This SMD device consists of an amber and yellow chip. So it is possible to choose the color in one device.

### PRODUCT GROUP AND PACKAGE DATA

- Product group: LED
- Package: SMD PLCC-4
- Product series: bicolor
- Angle of half intensity:  $\pm 60^\circ$

### FEATURES

- SMD LED with exceptional brightness
- Multicolored
- Luminous intensity categorized
- EIA and ICE standard package
- Compatible with automatic placement equipment
- Compatible with IR reflow, vapor phase and wave soldering processes according to CECC 00802 and J-STD-020
- Available in 8 mm tape
- Low profile package
- Non-diffused lens: excellent for coupling to light pipes and backlighting
- Low power consumption
- Luminous intensity ratio in one packaging unit  $I_{Vmax}/I_{Vmin} \leq 1.6$
- Preconditioning: according to JEDEC level 2a
- Compliant to RoHS Directive 2002/95/EC and in accordance to WEEE 2002/96/EC
- ESD-withstand voltage: up to 2 kV according to JESD22-A114-B
- AEC-Q101 qualified



### APPLICATIONS

- Automotive: backlighting in dashboards and switches
- Telecommunication: indicator and backlighting in telephone and fax
- Indicator and backlight in office equipment
- Flat backlight for LCDs, switches and symbols
- General use

### PARTS TABLE

PART	COLOR, LUMINOUS INTENSITY	TECHNOLOGY
VLMRY3420-GS08	Amber, $I_V = (355 \text{ to } 900) \text{ mcd}$ Yellow, $I_V = (560 \text{ to } 1120) \text{ mcd}$	AllnGaP on GaAs
VLMRY3420-GS18	Amber, $I_V = (355 \text{ to } 900) \text{ mcd}$ Yellow, $I_V = (560 \text{ to } 1120) \text{ mcd}$	AllnGaP on GaAs

\*\* Please see document "Vishay Material Category Policy": [www.vishay.com/doc?99902](http://www.vishay.com/doc?99902)

ABSOLUTE MAXIMUM RATINGS <sup>1)</sup> VLMRY3420					
PARAMETER	TEST CONDITION		SYMBOL	VALUE	UNIT
Reverse voltage per diode <sup>2)</sup>	$I_R = 10 \mu\text{A}$		$V_R$	5	V
DC forward current per diode	$T_{\text{amb}} \leq 65 \text{ }^\circ\text{C}$		$I_F$	50	mA
Surge forward current per diode			$I_{\text{FSM}}$	0.1	A
Power dissipation per diode			$P_V$	130	mW
Junction temperature			$T_j$	125	$^\circ\text{C}$
Operating temperature range			$T_{\text{amb}}$	- 40 to + 100	$^\circ\text{C}$
Storage temperature range			$T_{\text{stg}}$	- 40 to + 100	$^\circ\text{C}$
Thermal resistance junction/ambient	Mounted on PC board (pad size > 16 mm <sup>2</sup> )	1 chip on 2 chips on	$R_{\text{thJA}}$	480 650	K/W

Notes:

1)  $T_{\text{amb}} = 25 \text{ }^\circ\text{C}$ , unless otherwise specified

2) Driving the LED in reverse direction is suitable for short term application

OPTICAL AND ELECTRICAL CHARACTERISTICS <sup>1)</sup> VLMRY3420, AMBER							
PARAMETER	TEST CONDITION	PART	SYMBOL	MIN.	TYP.	MAX.	UNIT
Luminous intensity	$I_F = 50 \text{ mA}$	VLMRY3420	$I_V$	355		900	mcd
Dominant wavelength	$I_F = 50 \text{ mA}$		$\lambda_d$		617		nm
Peak wavelength	$I_F = 50 \text{ mA}$		$\lambda_p$		624		nm
Angle of half intensity	$I_F = 50 \text{ mA}$		$\phi$		$\pm 60$		deg
Forward voltage	$I_F = 50 \text{ mA}$		$V_F$		2.1	2.6	V
Reverse current	$V_R = 5 \text{ V}$		$I_R$			10	$\mu\text{A}$
Junction capacitance	$V_R = 0, f = 1 \text{ MHz}$		$C_j$		15		pF

Note:

1)  $T_{\text{amb}} = 25 \text{ }^\circ\text{C}$ , unless otherwise specified

OPTICAL AND ELECTRICAL CHARACTERISTICS <sup>1)</sup> VLMRY3420, YELLOW							
PARAMETER	TEST CONDITION	PART	SYMBOL	MIN.	TYP.	MAX.	UNIT
Luminous intensity	$I_F = 50 \text{ mA}$	VLMRY3420	$I_V$	560		1120	mcd
Dominant wavelength	$I_F = 50 \text{ mA}$		$\lambda_d$	581	588	594	nm
Peak wavelength	$I_F = 50 \text{ mA}$		$\lambda_p$		590		nm
Angle of half intensity	$I_F = 50 \text{ mA}$		$\phi$		$\pm 60$		deg
Forward voltage	$I_F = 50 \text{ mA}$		$V_F$		2.1	2.6	V
Reverse current	$V_R = 5 \text{ V}$		$I_R$			10	$\mu\text{A}$
Junction capacitance	$V_R = 0, f = 1 \text{ MHz}$		$C_j$		15		pF

CROSSING TABLE	
VISHAY	OSRAM
VLMRY3420	LAYT67B

LUMINOUS INTENSITY CLASSIFICATION AND GROUP COMBINATIONS <sup>1)</sup> VLMRY3420					
		RED			
		T2 355 to 450 mcd	U1 450 to 560 mcd	U2 560 to 710 mcd	V1 710 to 900 mcd
Y E L L O W	U2 560 to 710 mcd	VLMRY3420	VLMRY3420	VLMRY3420	VLMRY3420
	V1 710 to 900 mcd	VLMRY3420	VLMRY3420	VLMRY3420	VLMRY3420
	V2 900 to 1120 mcd	VLMRY3420	VLMRY3420	VLMRY3420	VLMRY3420

Note:

1) Luminous intensity is tested at a current pulse duration of 25 ms and an accuracy of  $\pm 11\%$ .

COLOR CLASSIFICATION		
GROUP	DOMINANT WAVELENGTH (nm)	
	YELLOW	
	MIN.	MAX.
1	581	584
2	583	586
3	585	588
4	587	590
5	589	592
6	591	594

Note:

Wavelengths are tested at a current pulse duration of 25 ms.

## TYPICAL CHARACTERISTICS

$T_{amb} = 25\text{ }^{\circ}\text{C}$ , unless otherwise specified

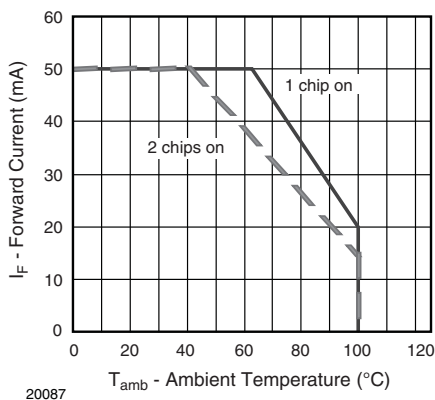


Figure 1. Forward Current vs. Ambient Temperature

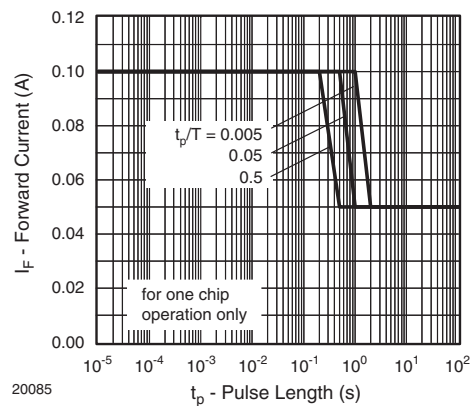


Figure 2. Forward Current vs. Pulse Duration

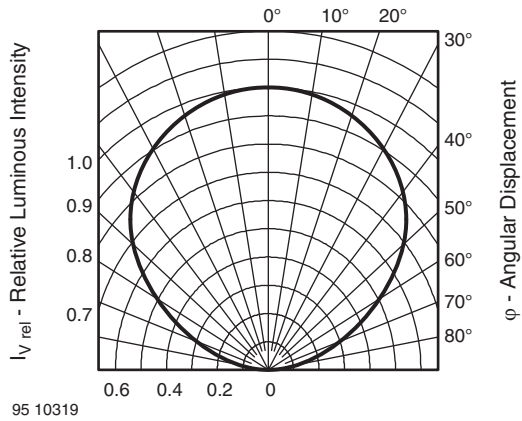


Figure 3. Rel. Luminous Intensity vs. Angular Displacement

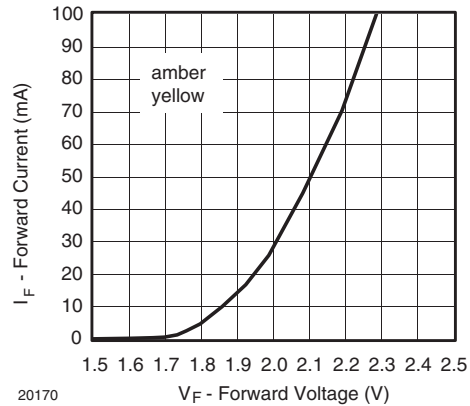


Figure 6. Relative Forward Voltage vs. Ambient Temperature

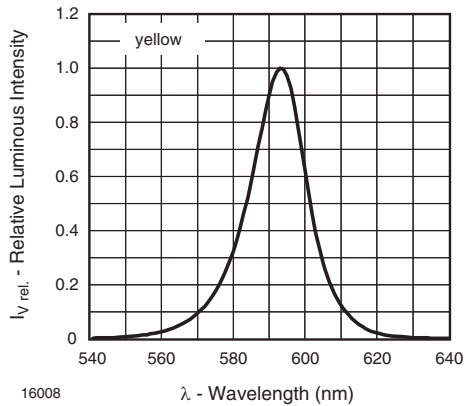


Figure 4. Relative Intensity vs. Wavelength

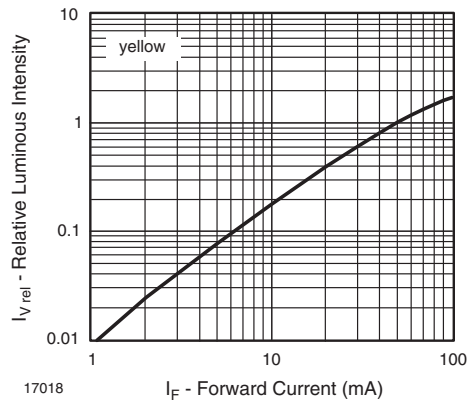


Figure 7. Relative Luminous Intensity vs. Forward Current

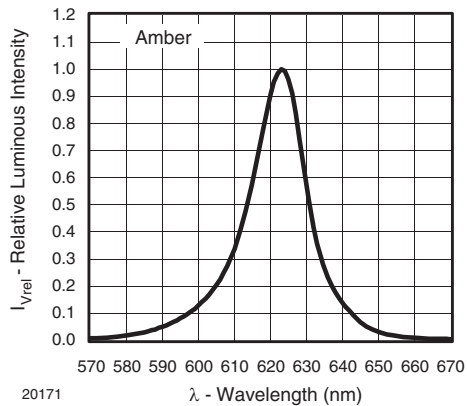


Figure 5. Relative Intensity vs. Wavelength

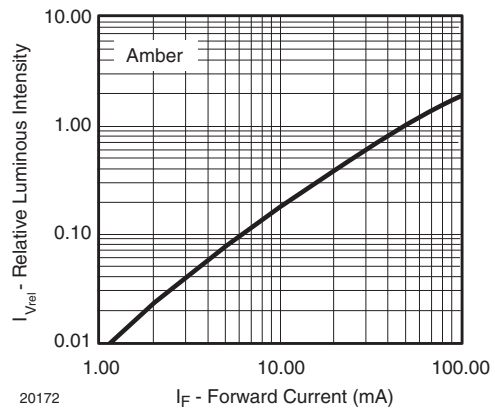


Figure 8. Relative Luminous Intensity vs. Forward Current

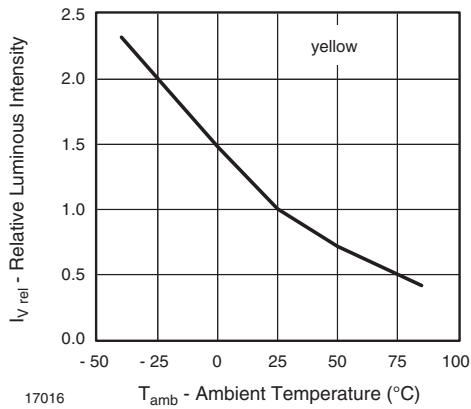


Figure 9. Rel. Luminous Intensity vs. Ambient Temperature

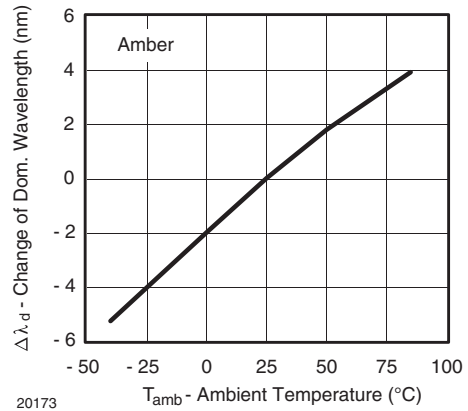


Figure 12. Change of Dominant Wavelength vs. Ambient Temperature

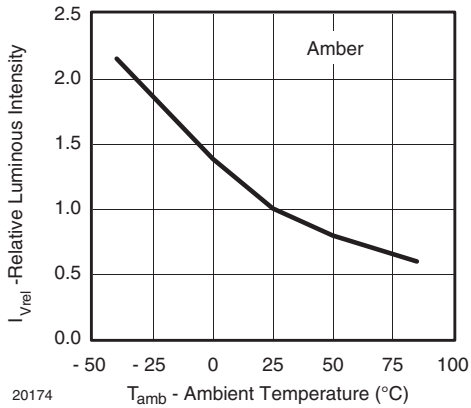


Figure 10. Rel. Luminous Intensity vs. Ambient Temperature

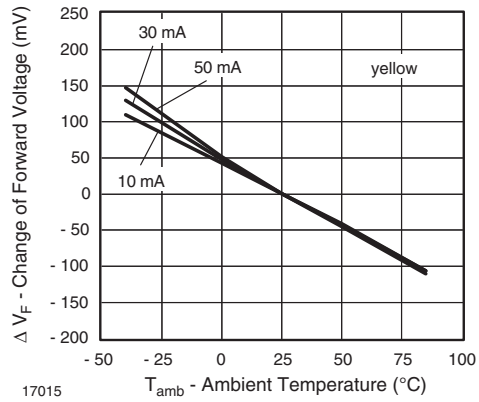


Figure 13. Change of Forward Voltage vs. Ambient Temperature

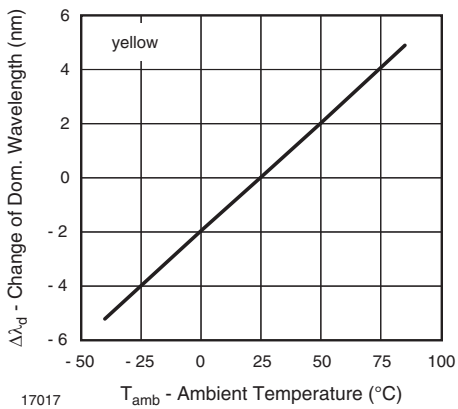


Figure 11. Change of Dominant Wavelength vs. Ambient Temperature

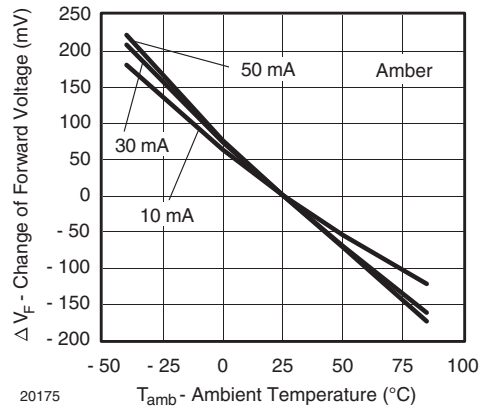
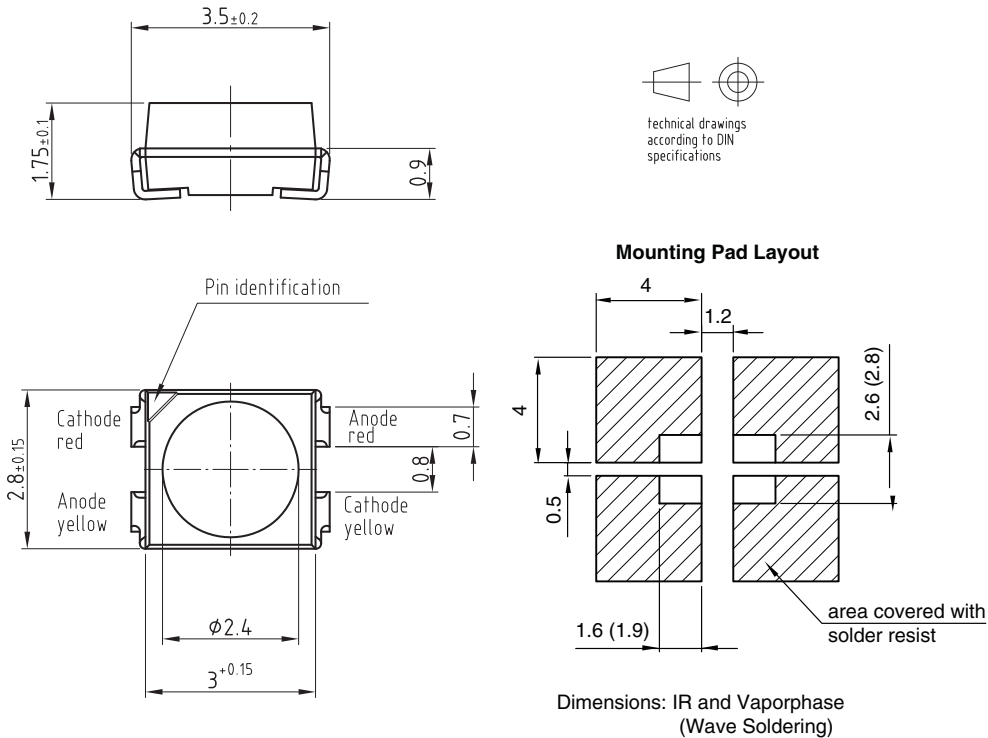


Figure 14. Change of Forward Voltage vs. Ambient Temperature

**PACKAGE DIMENSIONS** in millimeters



Drawing-No.: 6,541-5057.01-4  
 Issue: 5, 30.05.07  
 19899

**METHOD OF TAPING/POLARITY AND TAPE AND REEL  
 SMD LED (VLM.3 - SERIES)**

Vishay's LEDs in SMD packages are available in an antistatic 8 mm blister tape (in accordance with DIN IEC 40 (CO) 564) for automatic component insertion. The blister tape is a plastic strip with impressed component cavities, covered by a top tape.

**TAPING OF VLM.3...**

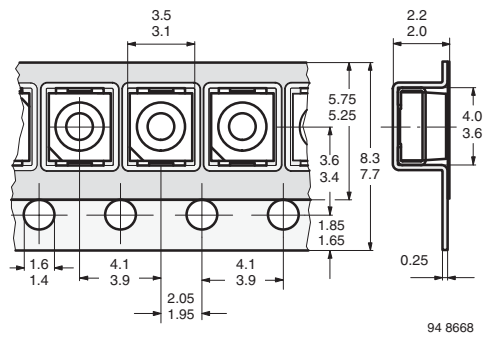
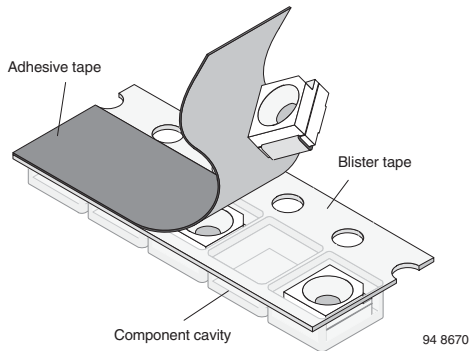


Figure 15. Tape Dimensions in mm for PLCC-2

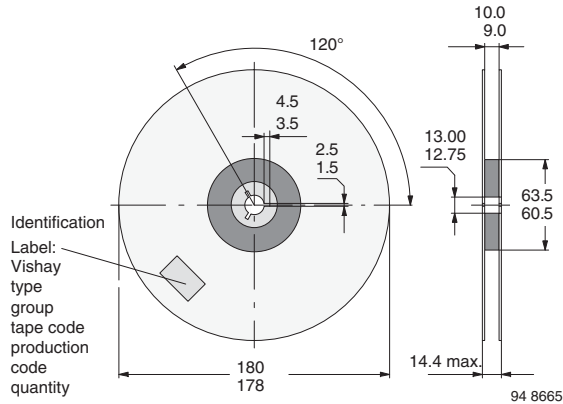
**REEL PACKAGE DIMENSION IN MILLIMETERS  
FOR SMD LEDs, TAPE OPTION GS08  
(= 1500 PCS.)**


Figure 16. Reel Dimensions - GS08

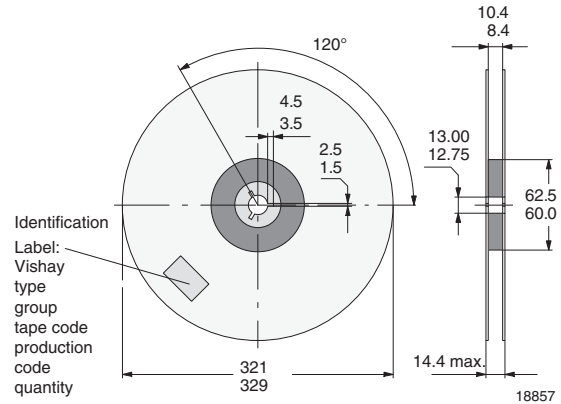
**REEL PACKAGE DIMENSION IN MILLIMETERS  
FOR SMD LEDs, TAPE OPTION GS18  
(= 8000 PCS.) PREFERRED**


Figure 17. Reel Dimensions - GS18

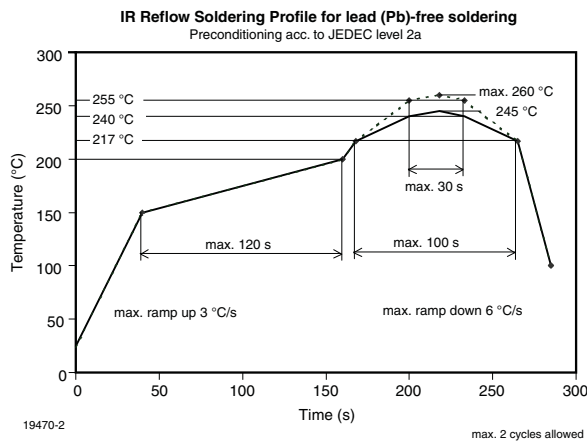
**SOLDERING PROFILE**


Figure 18. Vishay Lead (Pb)-free Reflow Soldering Profile (acc. to J-STD-020)

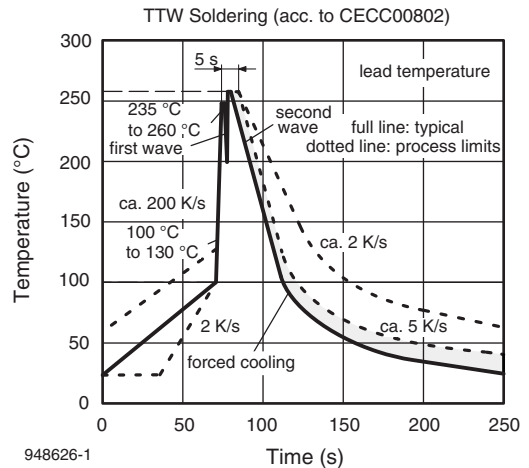
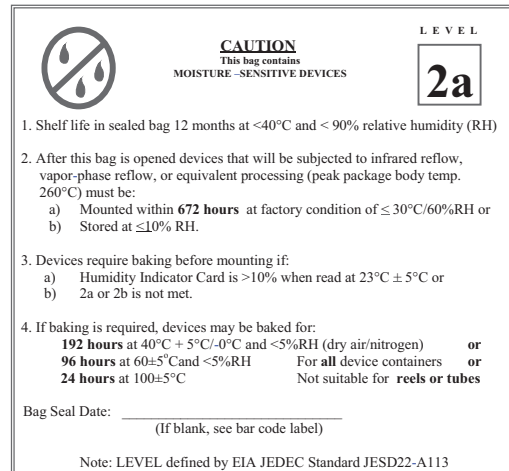
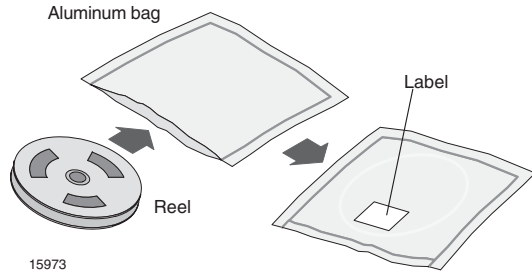


Figure 19. Double Wave Soldering of Opto Devices (all Packages)

### DRY PACKING

The reel is packed in an anti-humidity bag to protect the devices from absorbing moisture during transportation and storage.



Example of JESD22-A112 level 2a label

### FINAL PACKING

The sealed reel is packed into a cardboard box. A secondary cardboard box is used for shipping purposes.

### RECOMMENDED METHOD OF STORAGE

Dry box storage is recommended as soon as the aluminium bag has been opened to prevent moisture absorption. The following conditions should be observed, if dry boxes are not available:

- Storage temperature  $10^{\circ}\text{C}$  to  $30^{\circ}\text{C}$
- Storage humidity  $\leq 60\%$  RH max.

After more than 672 h under these conditions moisture content will be too high for reflow soldering.

In case of moisture absorption, the devices will recover to the former condition by drying under the following condition:

192 h at  $40^{\circ}\text{C} + 5^{\circ}\text{C}/ - 0^{\circ}\text{C}$  and  $< 5\%$  RH (dry air/ nitrogen) or

96 h at  $60^{\circ}\text{C} + 5^{\circ}\text{C}$  and  $< 5\%$  RH for all device containers or

24 h at  $100^{\circ}\text{C} + 5^{\circ}\text{C}$  not suitable for reel or tubes.

An EIA JEDEC standard JESD22-A112 level 2a label is included on all dry bags.

### ESD PRECAUTION

Proper storage and handling procedures should be followed to prevent ESD damage to the devices especially when they are removed from the antistatic shielding bag. Electro-static sensitive devices warning labels are on the packaging.

### VISHAY SEMICONDUCTORS STANDARD BAR CODE LABELS

The Vishay Semiconductors standard bar code labels are printed at final packing areas. The labels are on each packing unit and contain Vishay Semiconductors specific data.





## Disclaimer

ALL PRODUCT, PRODUCT SPECIFICATIONS AND DATA ARE SUBJECT TO CHANGE WITHOUT NOTICE TO IMPROVE RELIABILITY, FUNCTION OR DESIGN OR OTHERWISE.

Vishay Intertechnology, Inc., its affiliates, agents, and employees, and all persons acting on its or their behalf (collectively, "Vishay"), disclaim any and all liability for any errors, inaccuracies or incompleteness contained in any datasheet or in any other disclosure relating to any product.

Vishay makes no warranty, representation or guarantee regarding the suitability of the products for any particular purpose or the continuing production of any product. To the maximum extent permitted by applicable law, Vishay disclaims (i) any and all liability arising out of the application or use of any product, (ii) any and all liability, including without limitation special, consequential or incidental damages, and (iii) any and all implied warranties, including warranties of fitness for particular purpose, non-infringement and merchantability.

Statements regarding the suitability of products for certain types of applications are based on Vishay's knowledge of typical requirements that are often placed on Vishay products in generic applications. Such statements are not binding statements about the suitability of products for a particular application. It is the customer's responsibility to validate that a particular product with the properties described in the product specification is suitable for use in a particular application. Parameters provided in datasheets and/or specifications may vary in different applications and performance may vary over time. All operating parameters, including typical parameters, must be validated for each customer application by the customer's technical experts. Product specifications do not expand or otherwise modify Vishay's terms and conditions of purchase, including but not limited to the warranty expressed therein.

Except as expressly indicated in writing, Vishay products are not designed for use in medical, life-saving, or life-sustaining applications or for any other application in which the failure of the Vishay product could result in personal injury or death. Customers using or selling Vishay products not expressly indicated for use in such applications do so at their own risk and agree to fully indemnify and hold Vishay and its distributors harmless from and against any and all claims, liabilities, expenses and damages arising or resulting in connection with such use or sale, including attorneys fees, even if such claim alleges that Vishay or its distributor was negligent regarding the design or manufacture of the part. Please contact authorized Vishay personnel to obtain written terms and conditions regarding products designed for such applications.

No license, express or implied, by estoppel or otherwise, to any intellectual property rights is granted by this document or by any conduct of Vishay. Product names and markings noted herein may be trademarks of their respective owners.