

UNCONTROLLED DOCUMENT

SC:0.50

PART NUMBER

REV.

SSI-LXH072USBD

PRELIMINARY IN P/N DIR.

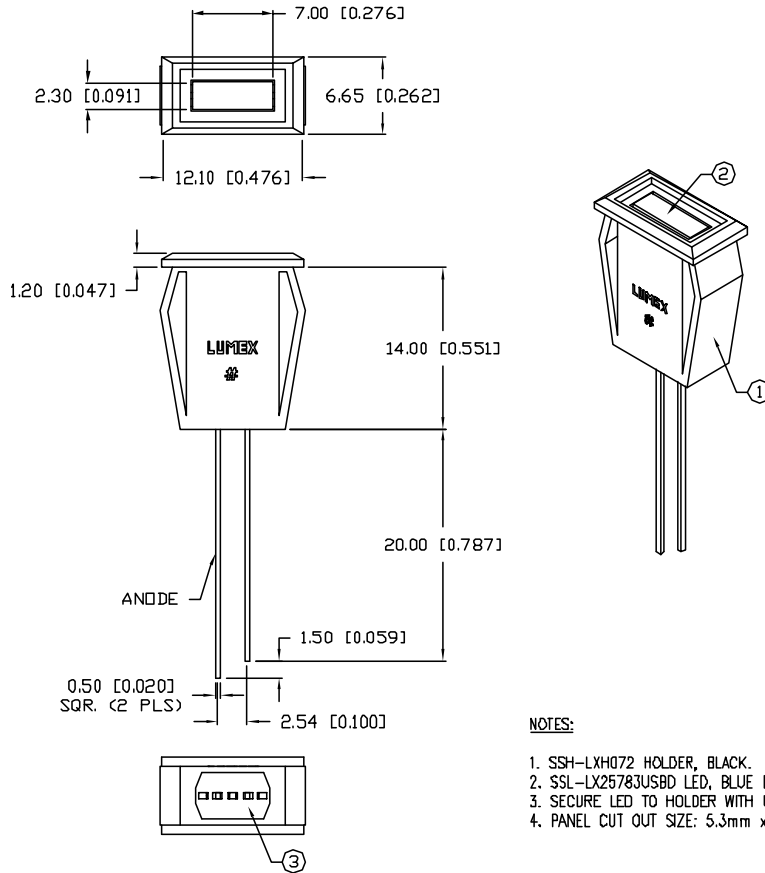

ELECTRO-OPTICAL CHARACTERISTICS		$T_A=25^\circ\text{C}$		$I_f=20\text{mA}$	
PARAMETER	MIN	TYP	MAX	UNITS	TEST COND
PEAK WAVELENGTH		470		nm	
FORWARD VOLTAGE		3.5	4.0	V_f	
REVERSE VOLTAGE	5.0			V_r	$I_f=100\mu\text{A}$
AXIAL INTENSITY		50		mcd	$I_f=20\text{mA}$
VIEWING ANGLE		110		$2x$ theta	
EMITTED COLOR:	BLUE				
EPOXY LENS FINISH:	BLUE DIFFUSED				

LIMITS OF SAFE OPERATION AT 25°C

PARAMETER	MAX	UNITS
PEAK FORWARD CURRENT*	100	mA
STEADY CURRENT	30	mA
POWER DISSIPATION	98	mW
DERATE FROM 25°C	-1.2	mW/ $^\circ\text{C}$
OPERATING, STORAGE TEMP.	-55 TO +100	$^\circ\text{C}$
SOLDERING TEMP.	+260	$^\circ\text{C}$
1.6mm FROM BODY		5 SEC. MAX

* $t < 10\mu\text{s}$

NOTES:

- SSH-LXH072 HOLDER, BLACK.
- SSL-LX25783USBD LED, BLUE LED.
- SECURE LED TO HOLDER WITH UV ACRYLIC.
- PANEL CUT OUT SIZE: 5.3mm x 11.0mm.

CAUTION: STATIC SENSITIVE DEVICE
FOLLOW PROPER E.S.D. HANDLING PROCEDURES
WHEN WORKING WITH THIS PART.

*UNLESS OTHERWISE SPECIFIED TOLERANCES PER DECIMAL PRECISION ARE: X=±1 (±0.039), XX=±0.5 (±0.020), XXX=±0.25 (±0.010), XXXX=±0.127 (±0.005). LEAD SIZE=±0.05 (±0.002), LEAD LENGTH=±0.75 (±0.030). MIN.=+DECIMAL PRECISION -0.00, MAX.=+0.00 -DECIMAL PRECISION

UNCONTROLLED DOCUMENT

REV.	PART NUMBER	CONFIDENTIAL INFORMATION	LUMEX	290 E. HELEN ROAD PALATINE, IL 60067-6976 PHONE: +1.847.359.2790 US WEB: www.lumex.com TW WEB: www.lumex.com.tw
	SSI-LXH072USBD	THE INFORMATION CONTAINED IN THIS DOCUMENT IS THE PROPERTY OF LUMEX INC. EXCEPT AS SPECIFICALLY AUTHORIZED IN WRITING BY LUMEX INC., THE HOLDER OF THIS DOCUMENT SHALL KEEP ALL INFORMATION CONTAINED HEREIN CONFIDENTIAL AND SHALL PROTECT SAME IN WHOLE OR IN PART FROM DISCLOSURE AND DISSEMINATION TO ALL THIRD PARTIES.		
	2.3mm x 7mm RECTANGULAR PANEL INDICATOR LED, 470nm InGaN BLUE LED, BLUE DIFFUSED LENS.	RELIABILITY NOTE OUR MANY YEARS OF EXPERIENCE DATA ACCUMULATION INDICATE THAT SOLDER HEAT IS A MAJOR CAUSE OF EARLY AND FUTURE FAILURE. PLEASE PAY ATTENTION TO YOUR SOLDERING PROCESS.	DRAWN BY: CT	CHECKED BY: APPROVED BY: DATE: 3.6.03 PAGE: 1 OF 1 SCALE: N/A