

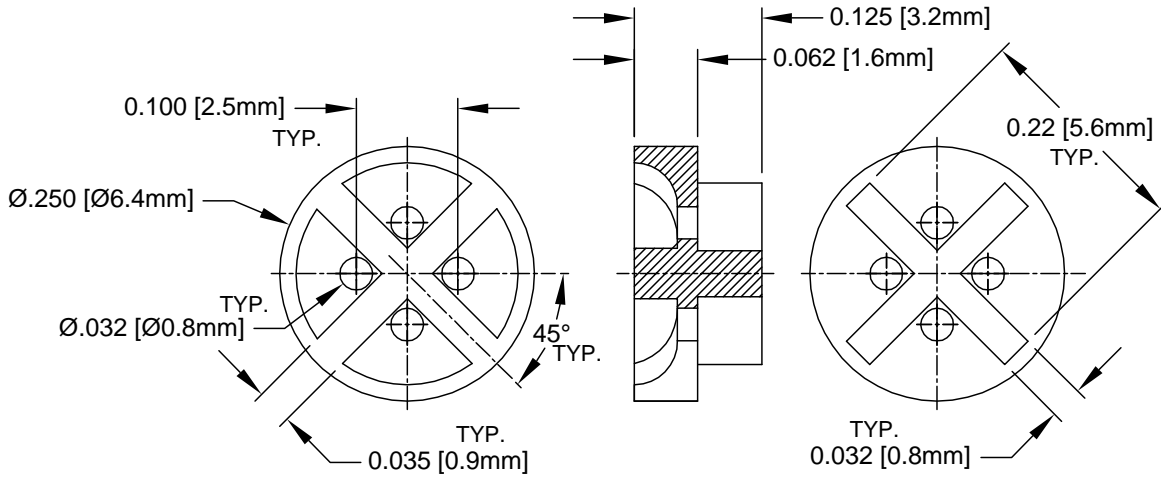

REV.	DESCRIPTION	DATE	APPROVED
B	Engineering Update w/o Changes	02/13/04	M. C.



2. MATERIAL: NYLON 6/6, 94V-2, WHITE. BIVAR MATERIAL CODE 04-WE.
 BASF ULTRAMID NYLON 6/6 A3K WHITE.
1. GENERAL SPECIFICATIONS: BIVAR MOLDED COMPONENT SPECIFICATION BV00-E101.

STANDARD TOLERANCE (UNLESS OTHERWISE SPECIFIED)		 4 THOMAS, IRVINE, CA. 92618 TEL: (949) 951-8808 FAX: (949) 951-3974	
DECIMALS	ANGULAR		
.X ± .1	X° ± 1°	TITLE: PERM-O-PAD TO-18 MOUNT PART NO: 113-125 REVISION: B	
.XX ± .01			
.XXX ± .005		DESIGNED: Shane Irving DATE: 06/29/98 CHECKED: R. Dienst DATE: 07/10/98 CAGE CODE : 32559 SHEET # 1 OF 1 <small>CAD GENERATED DOCUMENT. DO NOT MEASURE DRAWING.</small>	