





Messrs.					
Product Specification	Model:	NMTG-S12864IMNHSGW-20	Rev. No.	Issued Date.	Page.
			A	April. 07, 09	1 / 21

LIQUID CRYSTAL DISPLAY MODULE
MODEL: NMTG-S12864IMNHSGW-20
Customer's No.:

Acceptance

Microtips Technology Inc.
12F. No.31 Lane 169, Kang Ning St.,
His-Chih, Taipei Hsien, Taiwan, R.O.C.
FAX: 886-2-26958625

Approved and Checked by

Approved by	Checked by		Made by
			



Microtips Technology Inc.

Messrs.					
Product Specification	Model:	NMTG-S12864IMNHSGW-20	Rev. No.	Issued Date.	Page.
			A	April. 07, 09	3 / 21

CONTENTS

1.	General Specifications	4
2.	Electrical Specifications	5
2.1	Absolute Maximum Ratings	5
2.2	DC Characteristics	5
2.3	AC Characteristics	6
2.4	Power Supply ON/OFF Sequence	8
2.5	Lighting Specifications	9
3.	Optical Specifications	10
3.1	LCD Driving Voltage Recommended	10
3.2	Optical Characteristics	10
3.3	Definition of Viewing Angle and Optimum Viewing Area	11
3.4	Definition of Viewing Angle θ_f and θ_b	11
3.5	Definition of Contrast C	11
4.	I/O Terminal	12
4.1	Pin Assignment	12
4.2	Example of Power Supply	12
4.3	Block Diagram	13
5.	Reliability Test	14
5.1	Test Item	14
5.2	Judgment Standard	15
6.	Appearance Standards	16
6.1	Inspection Conditions	16
6.2	Definition of Applicable Zones	16
6.3	Standards	17
7.	Handling and Precautions	19
8.	Warranty:	20
9.	Dimensional Outlines	20



Microtips Technology Inc.

Messrs.					
Product Specification	Model:	NMTG-S12864IMNHSGW-20	Rev. No.	Issued Date.	Page.
			A	April. 07, 09	4 / 21

1. General Specifications

Operating Temperature	:	Min. -20°C ~ Max. 70°C
Storage Temperature	:	Min. -30°C ~ Max. 80°C
Dot Pixels	:	128 (W) x 64 (H) dots
Dot Size	:	0.50 (W) x 0.50 (H) mm
Dot Pitch	:	0.52 (W) x 0.52 (H) mm
Viewing Area	:	71.70 (W) x 39.0 (H) mm
Outline Dimensions	:	93.0 (W) x 70.0* (H) x 14.5 (D) mm
Weight	:	N/A
LCD Type	:	STN/ Negative, Blue mode/ Transmissive
Viewing Direction	:	6:00
Backlight	:	LED Edge-Light (White)
LCD LSI	:	SBN0064
Drawings	:	As attached drawings



Microtips Technology Inc.

Messrs.					
Product Specification	Model:	NMTG-S12864IMNHSGW-20	Rev. No.	Issued Date.	Page.
			A	April. 07, 09	5 / 21

2. Electrical Specifications

2.1 Absolute Maximum Ratings

$V_{SS} = 0V$

Parameter	Symbol	Conditions	Min.	Max.	Units
Supply Voltage (Logic)	$V_{DD} - V_{SS}$	--	- 0.3	7.0	V
Supply Voltage (LCD Drive)	V_{EE}	--	- 0.3	17.0	V
Input Voltage	V_I	--	- 0.3	$V_{DD} + 0.3$	V

2.2 DC Characteristics

$T_a = 25^\circ C, V_{SS} = 0V$

Parameter	Symbol	Conditions	Min.	Typ.	Max.	Units
Supply Voltage (Logic)	$V_{DD} - V_{SS}$	--	4.5	5.0	5.5	V
Supply Voltage (LCD Drive)	$V_{DD} - V_O$	Shown in 3.1				V
High Level (Input Voltage)	V_{IHT}	Note 1	2.0	--	V_{DD}	V
	V_{IHC}		$0.7V_{DD}$	--	V_{DD}	V
Low Level (Input Voltage)	V_{ILT}	Note 1	0	--	0.8	V
	V_{ILC}		0	--	$0.3V_{DD}$	V
High Level (Output Voltage)	V_{OH}	$I_{OH} = -205\mu A$ Note 2	2.4	--	--	V
Low Level (Output Voltage)	V_{OL}	$I_{OL} = 1.6mA$ Note 2	--	--	0.4	V
Supply Current	I_{DD}	$V_{DD} - V_{SS}$	--	0.6	1.1	mA
	I_{EE}	$V_{DD} - V_{EE}$	--	1.8	3.3	mA

Note 1 : Applied to /CS1, /CS2, E, D/I, DB0~DB7, R/W.

Note 2 : Applied to DB0~DB7.



Microtips Technology Inc.

Messrs.						
Product Specification	Model:	NMTG-S12864IMNHSGW-20	Rev. No.	Issued Date.	Page.	
			A	April. 07, 09	6 / 21	

2.3 AC Characteristics

2.3.1 Timing Characteristics

Ta= -20~70°C, V_{DD}=5.0V±10%

Parameter	Symbol	Condition	Rating		Unit	Note
			Min.	Max.		
Enable Cycle Time	t _{CYC}	--	1000	--	ns	1,2
Enable H/L Pulse Width	PW _{EH} , PW _{EL}	--	450	--	ns	1,2
Enable Rise/Fall Time	t _{Er} , t _{Ef}	--	--	25	ns	1,2
Address Setup Time	t _{AS}	--	140	--	ns	1,2
Address Hold Time	t _{AH}	--	10	--	ns	1,2
Data Setup Time	t _{DSW}	--	200	--	ns	
Data Delay Time	t _{DDR}	--	10	--	ns	2
Write Data Hold Time	t _{DHW}	--	--	320	ns	1
Read Data Hold Time	t _{DHR}	--	20	--	ns	2

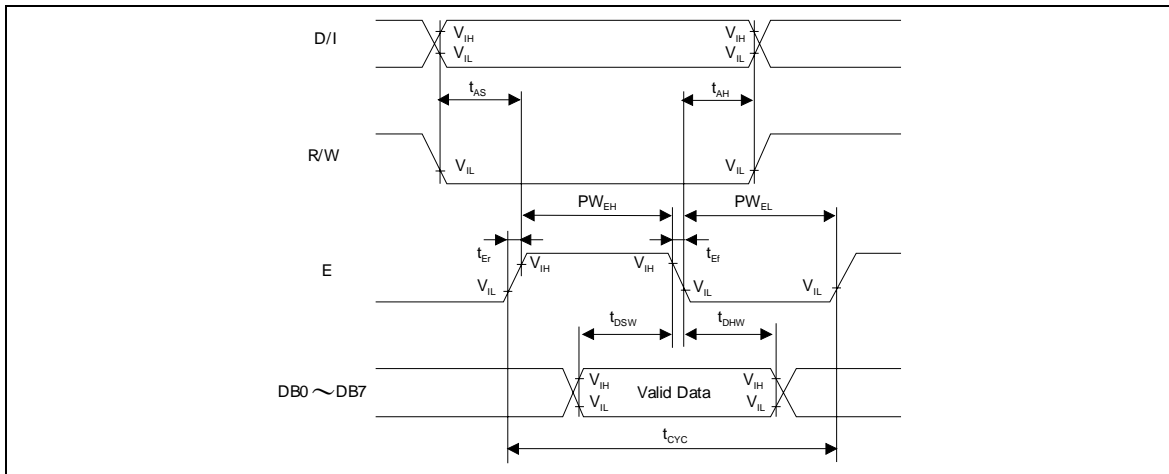

Note 1 : Write Operation Timing



Microtips Technology Inc.

Messrs.			
Product Specification	Model:	NMTG-S12864IMNHSGW-20	Rev. No.
			Issued Date.
			Page.
			<i>A</i>
			<i>April. 07, 09</i>
			<i>7 / 21</i>

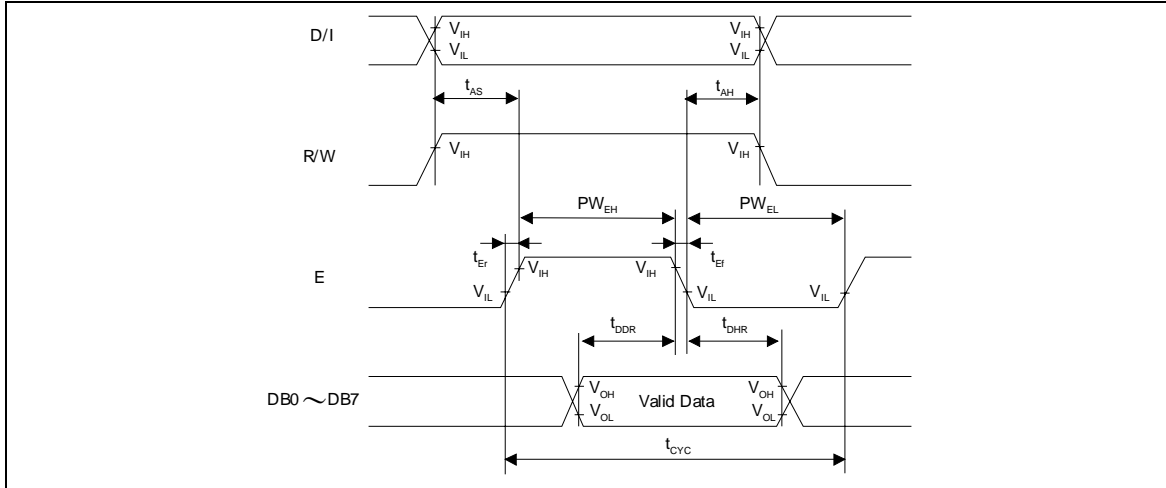

Note 2 : Read Operation Timing

2.3.2 Power Supply Initial Conditions

Parameter	Symbol	Min.	Max.	Units
Reset Low Level Time	t_{RST}	1.0	--	μs
Reset Rise Time	t_r	--	200	ns

Do not fail to set the system again because RESET during operation may destroy the data in all the registers except ON/OFF register and in RAM.



Microtips Technology Inc.

Messrs.			Rev. No.	Issued Date.	Page.
Product Specification	Model:	NMTG-S12864IMNHSGW-20	A	April. 07, 09	8 / 21

2.4 Power Supply ON/OFF Sequence

2.4.1 ON Sequence

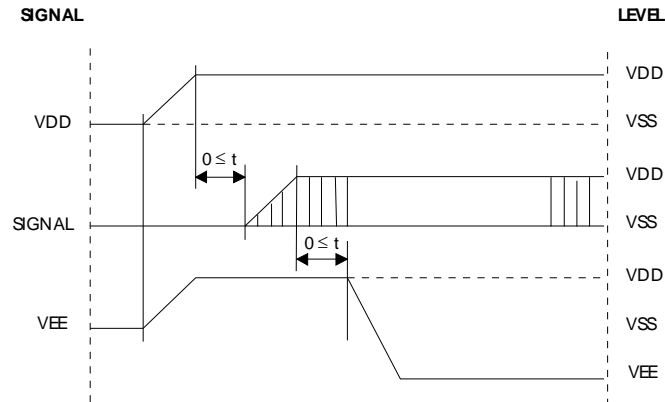

2.4.2 OFF Sequence

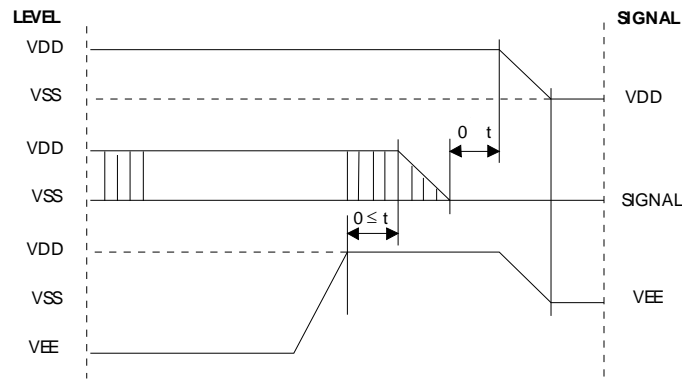

Please maintain the above sequence when turning on and off the power supply of the module. If VEE is supplied to the module while internal alternate signal for LCD driving (M) is unstable or RESET is active, DC component will be supplied to the LCD panel. This may cause damage to the LCD module.



Microtips Technology Inc.

Messrs.						
Product Specification	Model:	NMTG-S12864IMNHSGW-20	Rev. No.	Issued Date.	Page.	
			A	April. 07, 09	9 / 21	

2.5 Lighting Specifications

2.5.1 Absolute Maximum Ratings

Ta = 25°C

Parameter	Symbol	Conditions	Min.	Typ.	Max.	Units
Forward Current	I _F	--	--	--	60	mA
Reverse Voltage	V _R	--	--	--	5.0	V
LED Power Dissipation	P _D	--	--	--	252	mW
Operating Temp.	Top	--	-20	--	60	°C
Storage Temp.	T _{ST}	--	-25	--	65	°C

2.5.2 Operating Characteristics

Ta = 25°C

Parameter	Symbol	Conditions	Min.	Typ.	Max.	Units
Forward Voltage	V _F	I _F = 60mA	3.8	4.0	4.2	V
Luminance of Backlight Surface	L	I _F = 60mA	70	80	--	cd/m ²
Uniformity*	--	I _F = 60mA	--	70	--	%
Chromaticity Coordinates	X	I _F = 60mA	0.28	0.31	0.34	
	Y	I _F = 60mA	0.29	0.32	0.35	

*Uniformity = (Min./Max.) x 100%



Microtips Technology Inc.

Messrs.				Rev. No.	Issued Date.	Page.
Product Specification	Model:	NMTG-S12864IMNHSGW-20	A	April. 07, 09	10 / 21	

3. Optical Specifications

3.1 LCD Driving Voltage Recommended

Parameter	Symbol	Conditions	Min.	Typ.	Max.	Units
LCD Driving Voltage Note 1	$V_{DD}-V_O$	Ta = -20 °C	10.2	10.7	11.2	V
		Ta = 25 °C	9.60	10.1	10.6	V
		Ta = 70 °C	9.00	9.50	10.0	V

Note 1 : Voltage (Applied actual waveform to LCD panel) for the best contrast. The range of minimum and maximum shows tolerance of the operating voltage. The specified contrast ratio and response time are not guaranteed over the entire range.

3.2 Optical Characteristics

Ta=25 °C, 1/64 Duty, 1/9 Bias, $V_{DD} = 5.0V$ (Note 4), $\theta = 0^\circ$, $\phi = 270^\circ$

Parameter	Symbol	Conditions	Min.	Typ.	Max.	Units	
Contrast Ratio Note 1	C	$\theta = 0^\circ$, $\phi = 0^\circ$	2	6	--	--	
Viewing Angle Range	$\theta 2 - \theta 1$	--	30	90	--	deg.	
	$\phi 2 - \phi 1$	--	60	92	--	deg.	
Response Time	Rise Note 2	T_{ON}	Ta = -20 °C	--	800	2500	msec
	Decay Note 3	T_{OFF}	Ta = -20 °C	--	1500	1700	msec
	Rise Note 2	T_{ON}	Ta = 25 °C	--	110	270	msec
	Decay Note 3	T_{OFF}	Ta = 25 °C	--	200	300-	msec
	Rise Note 2	T_{ON}	Ta = 70 °C	--	--	--	msec
	Decay Note 3	T_{OFF}	Ta = 70 °C	--	--	--	msec

Note 1 : Contrast ratio is defined as follows.

$$CR = L_{OFF} / L_{ON}$$

L_{ON} : Luminance of the ON segments, L_{OFF} : Luminance of the OFF segments

Note 2 : The time that the luminance level reaches 90% of the saturation level from 0% when ON signal is applied.

Note 3 : The time that the luminance level reaches 10% of the saturation level from 100% when OFF signal is applied.

Note 4 : Definition of Driving Voltage V_D . Assuming that the typical driving waveforms shown below are applied to the LCD Panel at 1/A Duty - 1/B Bias (A : Duty Number, B : Bias Number). Driving voltage V_D is defined as follows: $V_D = (V_{th1} + V_{th2}) / 2$

V_{th1} : The voltage V_{O-P} that should provide 50% of the saturation level in the luminance at the segment which the ON signal is applied to.

V_{th2} : The voltage V_{O-P} that should provide 50% of the saturation level in the luminance at the segment which the OFF signal is applied to.

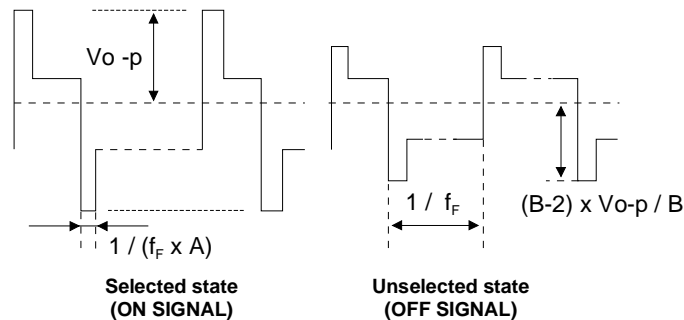

Microtips Technology Inc.

Messrs.			
Product Specification	Model:	NMTG-S12864IMNHSGW-20	Rev. No.
			Issued Date.
			Page.
			11 / 21

3.3 Definition of Viewing Angle and Optimum Viewing Area

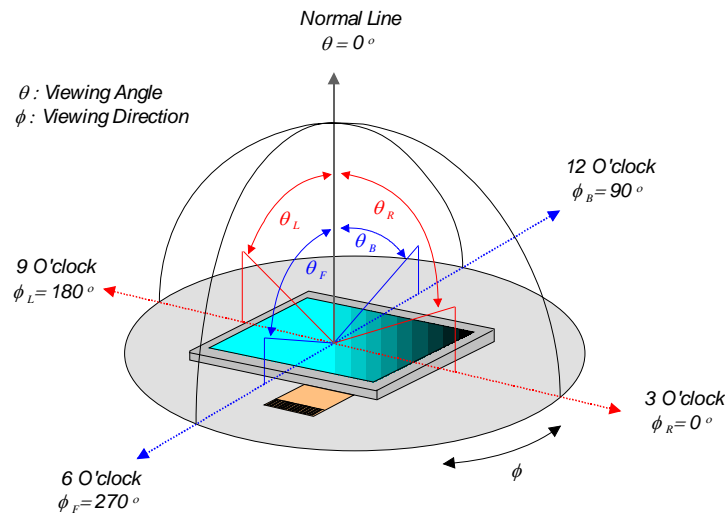

3.4 Definition of Viewing Angle θ_f and θ_b

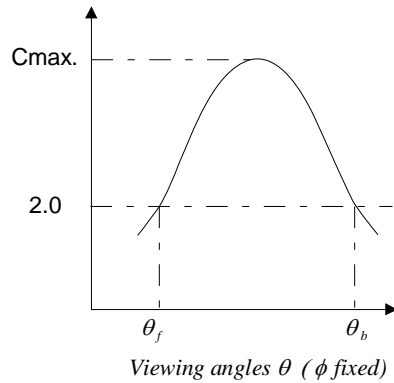

Optimum viewing angle with the naked eye and viewing angle θ at Cmax. Above are not always the same.

3.5 Definition of Contrast C

$C = \text{Brightness of selected dot (B1)} / \text{Brightness of unselected dot (B2)}$

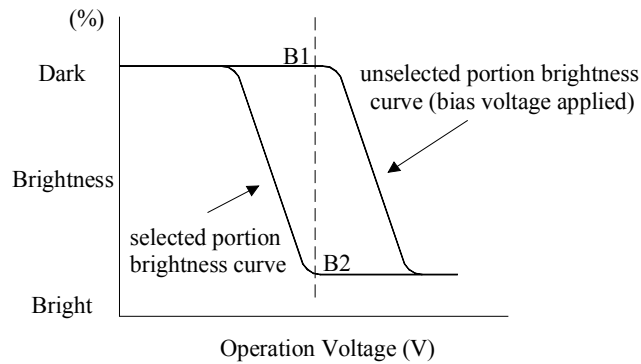

Microtips Technology Inc.

Messrs.			
Product Specification	Model:	NMTG-S12864IMNHSGW-20	Rev. No.
			Issued Date.
			Page.
			A April. 07, 09 12 / 21

4. I/O Terminal

4.1 Pin Assignment

No.	Symbol	Level	Function
1	VSS	--	Power Supply (0V, GND)
2	VDD	--	Power Supply for Logic
3	VLCD (Vo)	--	Power Supply for LCD Drive
4	D/I	H / L	H: D0~D7 are Display Signal L: D0~D7 are Instructions
5	R/W	H / L	Read/Write Select Signal H: Read L: Write
6	E	H, H →L	Enable Signal (No pull-up Resistor)
7	DB0	I/O	Data Bus Line
8	DB1	I/O	Data Bus Line
9	DB2	I/O	Data Bus Line
10	DB3	I/O	Data Bus Line
11	DB4	I/O	Data Bus Lin
12	DB5	I/O	Data Bus Line
13	DB6	I/O	Data Bus Line
14	DB7	I/O	Data Bus Line
15	/CS1	H / L	Chip Select Signal L: Active
16	/CS2	H / L	Chip Select Signal L: Active
17	/RST	H / L	Reset Signal L: Reset
18	VEE	--	Power Supply for LCD Drive
19	BKL1(LED_A)	--	Power Supply for LED Backlight -Anode Terminal
20	BKL2(LED_K)	--	Power Supply for LED Backlight -Cathode Terminal

4.2 Example of Power Supply

It is recommended to apply a potentiometer for the contrast adjust due to the tolerance of the driving voltage and its temperature dependence.

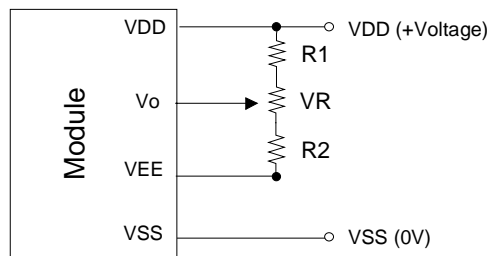

$$R1+R2+VR=10 \sim 20K\Omega$$



Microtips Technology Inc.

Messrs.			
Product Specification	Model:	NMTG-S12864IMNHSGW-20	Rev. No.
			Issued Date.
			Page.
			<i>A</i> <i>April. 07, 09</i> <i>13 / 21</i>

4.3 Block Diagram

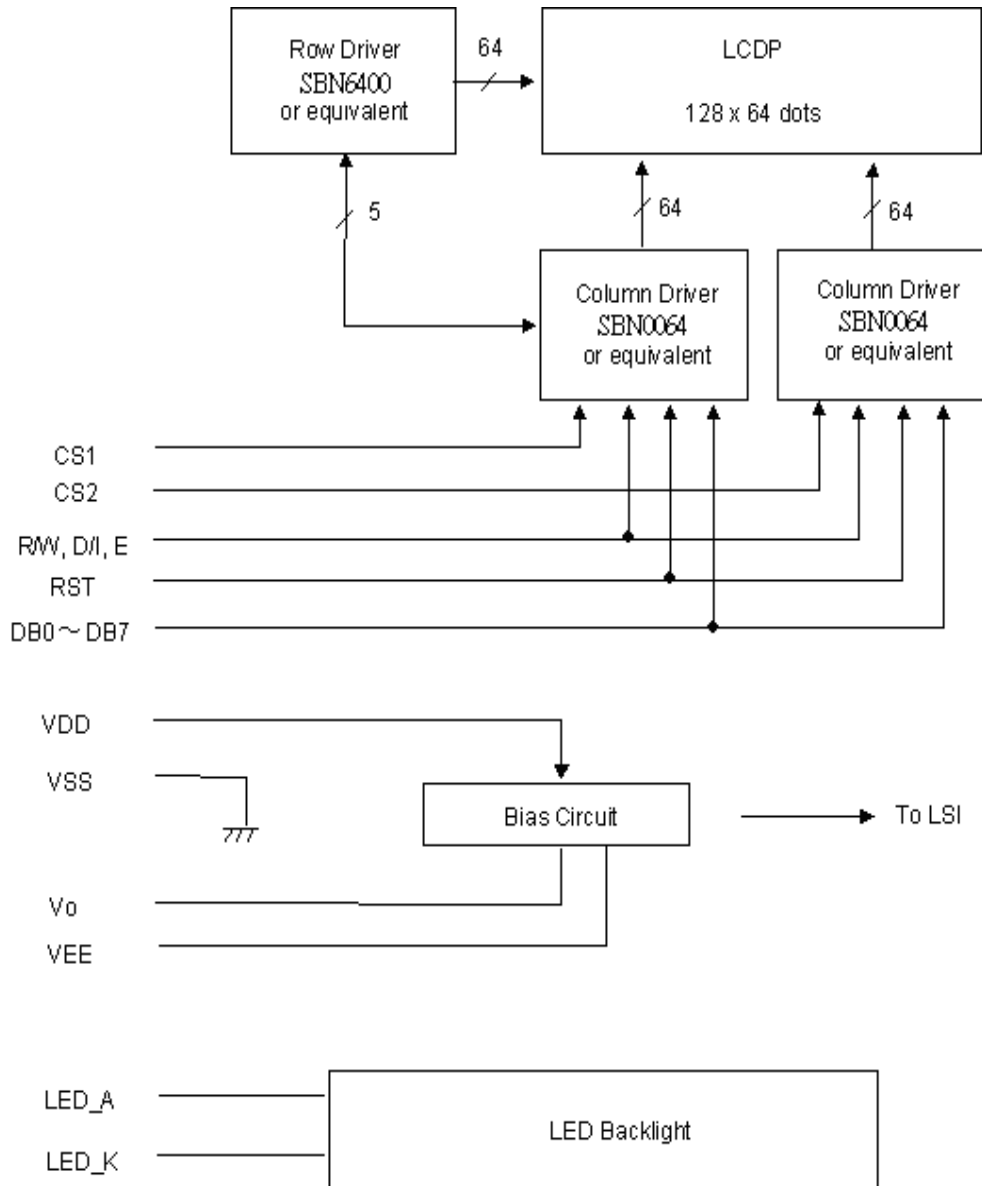

Microtips Technology Inc.

Messrs.			
Product Specification	Model:	NMTG-S12864IMNHSGW-20	Rev. No.
			Issued Date.
			Page.
			A April. 07, 09 14 / 21

5. Reliability Test

5.1 Test Item

No change on display and in operation under the following test condition.

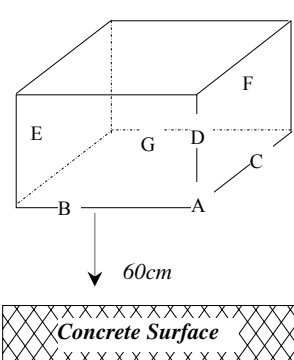
No.	Test Item	Description	Condition	Note
1.	High Temperature (Operation)	Durability test under long time high temperature with electrical stress (voltage, current)	70°C ± 2°C 96hrs	
2.	High Temperature (Storage)	Durability test under long time high temperature storage	80°C ± 2°C 96hrs	4
3.	Low Temperature (Operation)	Durability test under long time low temperature with electrical stress (voltage, current)	-20°C ± 2°C, 96hrs	3
4.	Low Temperature (Storage)	Durability test under long time low temperature storage	-30°C ± 2°C, 96hrs	3, 4
5.	Damp Proof Test	Durability test under long time high temperature and high humidity	40°C ± 2°C, 90~95% RH 96hrs	3, 4
6.	Vibration Test	Total fixed amplitude: 1.5mm Vibration frequency: 10~55Hz One cycle 60 seconds to 3 directions of X, Y, Z for each 15 minutes	--	5
7.	Drop Test	To be measured after dropping from 60cm high on the concrete surface in packing state.  <i>Dropping method corner dropping</i> <i>A corner: once</i> <i>Edge dropping</i> <i>B, C, D edge: once</i> <i>Face dropping</i> <i>E, F, G face: once</i>		

Note 1: Unless otherwise specified, tests will be conducted under the following condition,

Temperature : 25°C ± 2°C

Humidity : 65% ± 5%

Note 2: Unless otherwise specified, tests will be not conducted under functioning state.

Note 3: No dew condensation to be observed.

Note 4: The function test shall be conducted after 4 hours storage at the normal temperature and humidity after removed from the test chamber.

Note 5: Vibration test will be conducted to the product itself without putting it in a container.



Microtips Technology Inc.

Messrs.				Rev. No.	Issued Date.	Page.
Product Specification	Model:	NMTG-S12864IMNHSGW-20		A	April. 07, 09	15 / 21

5.2 Judgment Standard

Failure Mode	Test Item							Judgment Standard
	1	2	3	4	5	6	7	
Orientation	*	*	*	*	*			No remarkable degradation of appearance under bias/ non-bias condition
Current Value (IAC)	*	*	*	*	*			No remarkable increase
Contrast	*		*	*	*			No remarkable poor contrast
Domain	*	*	*	*	*			Less than 20% of all dots have reverse tilt of more than on third of one dot area.
Bubble (Inside Cell)	*	*	*	*	*	*		As per "Appearance Standard" (Note. Including one which disappear after 25°C 2H)
Polarizer	*				*	*		As per "Appearance Standard" no remarkable appearance change
Glass Damage							*	As per "Appearance Standard"

- Note. 1. * is strong linkage between Failure Mode and Test Item.
 2. Number of Test Item should be referred to former page.
 3. Judgment and Standard value should be fixed by other inspection standard and criteria samples.



Microtips Technology Inc.

Messrs.			
Product Specification	Model:	NMTG-S12864IMNHSGW-20	Rev. No.
			Issued Date.
			Page.
			<i>A</i>
			<i>April. 07, 09</i>
			<i>16 / 21</i>

6. Appearance Standards

6.1 Inspection Conditions

The LCD shall be inspected under 40W white fluorescent light. The distance between the eyes and the sample shall be more than 30cm. All directions for inspecting the sample should be within 45° against perpendicular line.

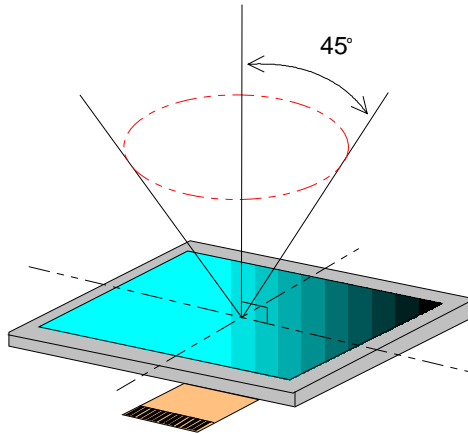

6.2 Definition of Applicable Zones

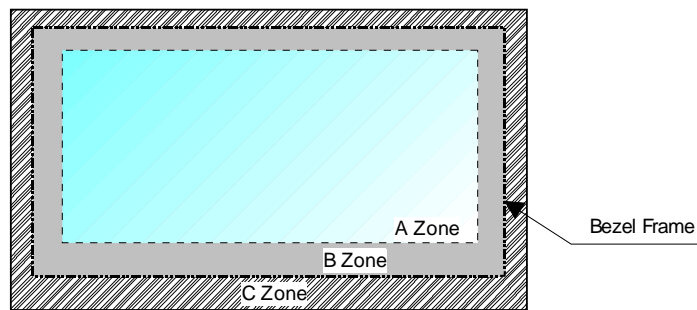

A Zone : Active display area

B Zone : Area from outside of "A Zone" to validity viewing area

C Zone : Rest parts

A Zone + B Zone = Validity viewing area



Microtips Technology Inc.

Messrs.					
Product Specification	Model:	NMTG-S12864IMNHSGW-20	Rev. No.	Issued Date.	Page.
			A	April. 07, 09	17 / 21

6.3 Standards

No.	Parameter	Criteria																																																							
1.	Black and White Spots, Foreign Substances	<p>(1) Round Shape</p> <table border="1"> <thead> <tr> <th rowspan="2">Dimension (mm) \ Zone</th> <th colspan="3">Acceptable Number</th> </tr> <tr> <th>A</th> <th>B</th> <th>C</th> </tr> </thead> <tbody> <tr> <td>D ≤ 0.1</td> <td>*</td> <td>*</td> <td>*</td> </tr> <tr> <td>0.1 < D ≤ 0.2</td> <td>3</td> <td>5</td> <td>*</td> </tr> <tr> <td>0.2 < D ≤ 0.25</td> <td>2</td> <td>3</td> <td>*</td> </tr> <tr> <td>0.25 < D ≤ 0.3</td> <td>0</td> <td>1</td> <td>*</td> </tr> <tr> <td>0.3 < D</td> <td>0</td> <td>0</td> <td>*</td> </tr> </tbody> </table> <p>D = (Long + Short)/2 *: Disregard</p> <p>(2) Line Shape</p> <table border="1"> <thead> <tr> <th rowspan="2">Zone \ X (mm)</th> <th rowspan="2">Zone \ Y (mm)</th> <th colspan="3">Acceptable Number</th> </tr> <tr> <th>A</th> <th>B</th> <th>C</th> </tr> </thead> <tbody> <tr> <td>--</td> <td>0.03 ≥ W</td> <td>*</td> <td>*</td> <td>*</td> </tr> <tr> <td>2.0 ≥ L</td> <td>0.05 ≥ W</td> <td>3</td> <td>3</td> <td>*</td> </tr> <tr> <td>1.0 ≥ L</td> <td>0.1 ≥ W</td> <td>3</td> <td>3</td> <td>*</td> </tr> <tr> <td>--</td> <td>0.1 < W</td> <td colspan="3">In the same way (1)</td> </tr> </tbody> </table> <p>X : Length Y: Width *: Disregard</p> <p>Total defects shall not exceed 5.</p>	Dimension (mm) \ Zone	Acceptable Number			A	B	C	D ≤ 0.1	*	*	*	0.1 < D ≤ 0.2	3	5	*	0.2 < D ≤ 0.25	2	3	*	0.25 < D ≤ 0.3	0	1	*	0.3 < D	0	0	*	Zone \ X (mm)	Zone \ Y (mm)	Acceptable Number			A	B	C	--	0.03 ≥ W	*	*	*	2.0 ≥ L	0.05 ≥ W	3	3	*	1.0 ≥ L	0.1 ≥ W	3	3	*	--	0.1 < W	In the same way (1)		
Dimension (mm) \ Zone	Acceptable Number																																																								
	A	B	C																																																						
D ≤ 0.1	*	*	*																																																						
0.1 < D ≤ 0.2	3	5	*																																																						
0.2 < D ≤ 0.25	2	3	*																																																						
0.25 < D ≤ 0.3	0	1	*																																																						
0.3 < D	0	0	*																																																						
Zone \ X (mm)	Zone \ Y (mm)	Acceptable Number																																																							
		A	B	C																																																					
--	0.03 ≥ W	*	*	*																																																					
2.0 ≥ L	0.05 ≥ W	3	3	*																																																					
1.0 ≥ L	0.1 ≥ W	3	3	*																																																					
--	0.1 < W	In the same way (1)																																																							
2.	Air Bubbles (between glass & polarizer)	<table border="1"> <thead> <tr> <th rowspan="2">Dimension (mm) \ Zone</th> <th colspan="3">Acceptable Number</th> </tr> <tr> <th>A</th> <th>B</th> <th>C</th> </tr> </thead> <tbody> <tr> <td>D ≤ 0.3</td> <td>*</td> <td>*</td> <td>*</td> </tr> <tr> <td>0.3 < D ≤ 0.4</td> <td>3</td> <td>*</td> <td>*</td> </tr> <tr> <td>0.4 < D ≤ 0.6</td> <td>2</td> <td>3</td> <td>*</td> </tr> <tr> <td>0.6 < D</td> <td>0</td> <td>0</td> <td>*</td> </tr> </tbody> </table> <p>*: Disregard</p> <p>Total defects shall not exceed 3.</p>	Dimension (mm) \ Zone	Acceptable Number			A	B	C	D ≤ 0.3	*	*	*	0.3 < D ≤ 0.4	3	*	*	0.4 < D ≤ 0.6	2	3	*	0.6 < D	0	0	*																																
Dimension (mm) \ Zone	Acceptable Number																																																								
	A	B	C																																																						
D ≤ 0.3	*	*	*																																																						
0.3 < D ≤ 0.4	3	*	*																																																						
0.4 < D ≤ 0.6	2	3	*																																																						
0.6 < D	0	0	*																																																						

To be continued.....



Microtips Technology Inc.

Messrs.					
Product Specification	Model:	NMTG-S12864IMNHSGW-20	Rev. No.	Issued Date.	Page.
			A	April. 07, 09	18 / 21

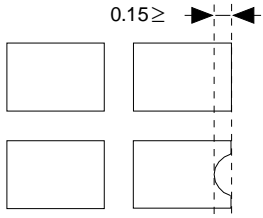
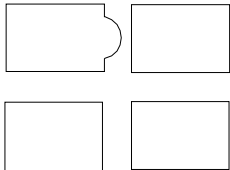
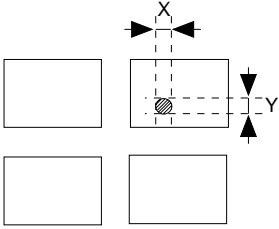
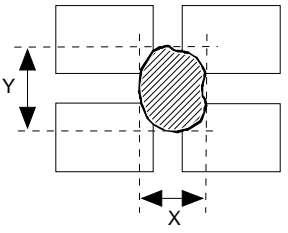
No.	Parameter	Criteria
3.	The Shape of Dot	<p>(1) Dot Shape (with Dent)</p>  <p>0.15 ≥</p> <p>As per the sketch of left hand.</p> <p>(2) Dot Shape (with Projection)</p>  <p>Should not be connected to next dot.</p> <p>(3) Pin Hole</p>  <p>$(X+Y)/2 \leq 0.2\text{mm}$ (Less than 0.1mm is no counted.)</p> <p>(4) Deformation</p>  <p>$(X+Y)/2 \leq 0.2\text{mm}$</p> <p>Total acceptable number: 1/dot, 5/cell (Defect number of (4): 1pc.)</p>
4.	Polarizer Scratches	Not to be conspicuous defects.
5.	Polarizer Dirts	If the stains are removed easily from LCDP surface, the module is not defective.
6.	Complex Foreign Substance Defects	Black spots, line shaped foreign substance or air bubbles between glass & polarizer should be 5pcs maximum in total.
7.	Distance between different Foreign Substance defects	$D \leq 0.2$: 20mm or more $0.2 < D$: 40mm or more



Microtips Technology Inc.

Messrs.					
Product Specification	Model:	NMTG-S12864IMNHSGW-20	Rev. No.	Issued Date.	Page.
			A	April. 07, 09	19 / 21

7. Handling and Precautions

The Following precautions will guide you in handling our product correctly.

- 1 Liquid crystal display devices
 - 1.1 The liquid crystal display device panel used in the liquid crystal display module is made of plate glass. Avoid any strong mechanical shock. Should the glass break handle it with care.
 - 1.2 The polarizer adhering to the surface of the LCD is made of a soft material. Guard against scratching it.
- 2 Care of the liquid crystal display module against static electricity discharge.
 - 2.1 When working with the module, be sure to ground your body and any electrical equipment you may be using. We strongly recommend the use of anti static mats (made of rubber), to protect work tables against the hazards of electrical shock.
 - 2.2 Avoid the use of work clothing made of synthetic fibers. We recommend cotton clothing or other conductivity-treated fibers.
 - 2.3 Slowly and carefully remove the protective film from the LCD module, since this operation can generate static electricity.
- 3 When the LCD module alone must be stored for long periods of time:
 - 3.1 Protect the modules from high temperature and humidity.
 - 3.2 Keep the modules out of direct sunlight or direct exposure to ultra-violet rays.
 - 3.3 Protect the modules from excessive external forces.
- 4 Use the module with a power supply that is equipped with an over current protector circuit, since the module is not provided with this protective feature.
- 5 Do not ingest the LCD fluid itself should it leak out of a damaged LCD module. Should hands or clothing come in contact with LCD fluid, wash immediately with soap.
- 6 Conductivity is not guaranteed for models that use metal holders where solder connections between the metal holder and the PCB are not used. Please contact us to discuss appropriate ways to assure conductivity.



Microtips Technology Inc.

Messrs.					
Product Specification	Model:	NMTG-S12864IMNHSGW-20	Rev. No.	Issued Date.	Page.
			A	April. 07, 09	20 / 21

8. Warranty:

This product has been manufactured to your company’s specifications as a part for use in your company’s general electronic products. It is guaranteed to perform according to delivery specifications. For any other use apart from general electronic equipment, we cannot take responsibility if the product is used in medical devices, nuclear power control equipment, aerospace equipment, fire and security systems, or any other applications in which there is a direct risk to human life and where extremely high levels of reliability are required. If the product is to be used in any of the above applications, we will need to enter into a separate product liability agreement.

- 1 13 months guarantee starts from the date code.
- 2 We cannot accept responsibility for any defect, which may arise from additional manufacturing of the product (including disassembly and reassembly), after product delivery.
- 3 We cannot accept responsibility for any defect, which may arise after the application of strong external force to the product.
- 4 We cannot accept responsibility for any defect, which may arise due to the application of static electricity after the product has passed your company’s acceptance inspection procedures.
- 5 We cannot accept responsibility for industrial property, which may arise through the use of your product, with exception to those issues relating directly to the structure or method of manufacturing of our product. Microtips-origin longer than one year from Microtips production.

9. Dimensional Outlines

- See the next page.....



Microtips Technology Inc.

REV.	DESCRIPTION	DRAWN	CHECK	APP'D	DATE
1	Production Release	Troy He	Chris Luo		08/19/02

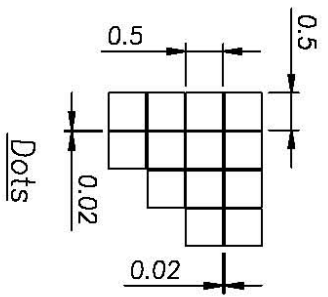
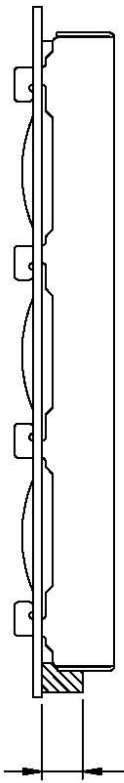
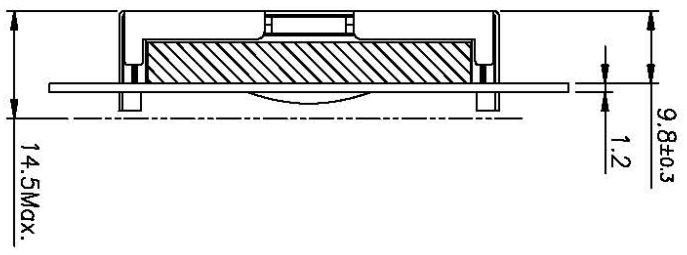
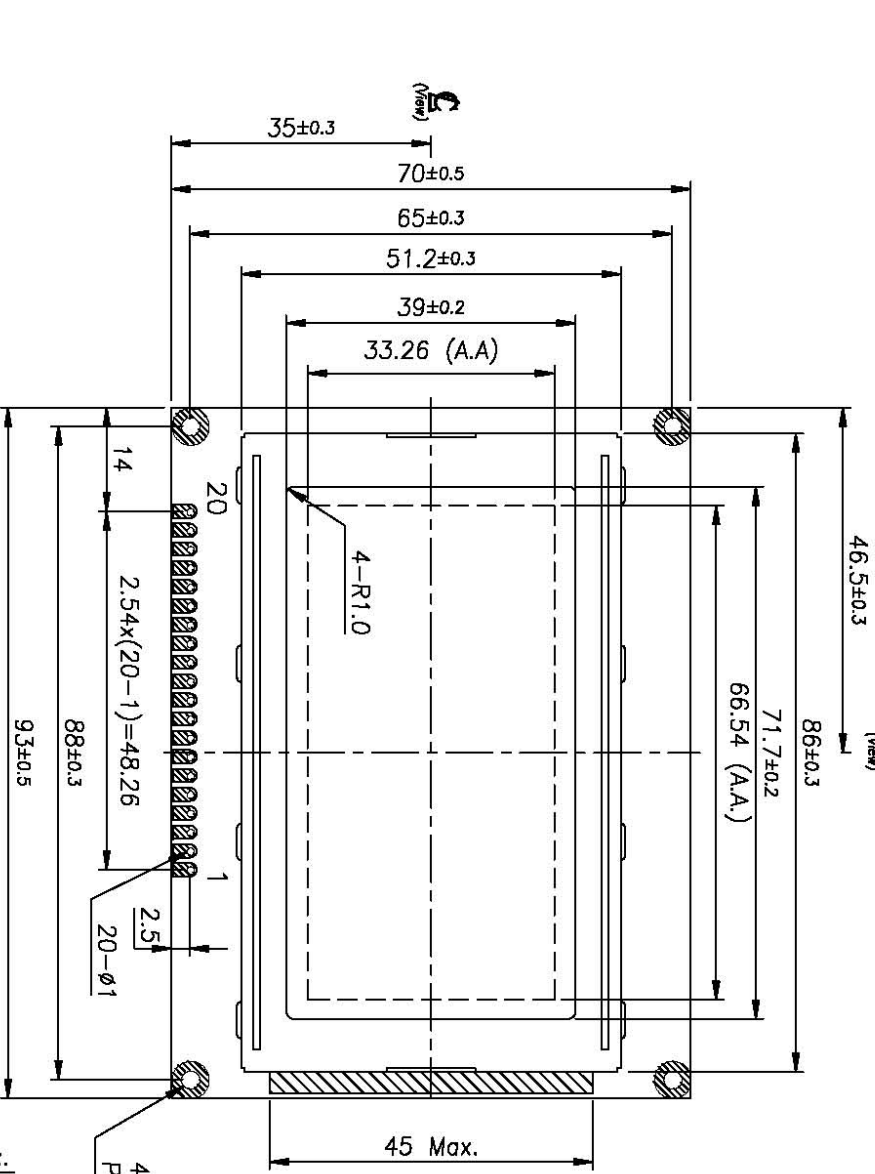

Note:
Otherwise specified: ±0.4

PIN ASSIGNMENT	
1.	VSS
2.	VDD
3.	V0
4.	D/I
5.	R/W
6.	E
7.	DB0
8.	DB1
9.	DB2
10.	DB3
11.	DB4
12.	DB5
13.	DB6
14.	DB7
15.	CS1
16.	CS2
17.	RST
18.	VEE
19.	BKL1
20.	BKL2

NO.	M-12864(H)	Q'TY	1	DATE:	01/02/02	MATERIAL	FINISH
PART NAME							
DRAWN	Troy He	CHECK	Chris Luo	APP'D	Raymond	UNIT: MM	SCALE: 1/1
							PRODUCT: MTG-12864
							DWG NO.: G1286410
							FILE: DWG\Design\LCM\MTG\MTG-12864\2D
							SHEET 1 / 1
							Rev: A



Troy He
Chris Luo
Raymond

6 5 4 3 2 1