

DOGXL GRAPHIC SERIES

160x104 DOTS WITH SPI AND I²C



EA DOGXL160W-7 +
EA LED78x64-A



EA DOGXL160B-7 +
EA LED78x64-W



EA DOGXL160W-7 +
EA LED78x64-W

available in low quantities !
flat: 6.5mm with LED b./l. mounted

FEATURES

- * WITH UC1610 CONTROLLER FOR SPI 3-/4-WIRE. 8-/9-BIT AND 2-WIRE I²C INTERFACE
- * HIGH-CONTRAST LCD SUPERTWIST DISPLAY (STN AND FSTN) WITH 15µm DOTGAP
- * OPTIONAL LED BACKLIGHTS IN VARIOUS COLORS
- * 160x104 PIXELS (CORRESPONDS TO 13 LINES à 26 CHARACTERS OR 6x20 LARGE CHAR.)
- * POWER SUPPLY: SINGLE SUPPLY 2.6V TO 3.3V (TYPICALLY 700µA)
- * NO ADDITIONAL VOLTAGES REQUIRED
- * OPERATING TEMPERATURE RANGE -20°C TO +70°C (STORAGE -30°C TO +80°C)
- * LED BACKLIGHTING 10mA TO 150mA
- * NO MOUNTING REQUIRED: SIMPLY SOLDER INTO PCB

ORDERING CODE

GRAPHICS DISPLAY 160x104, 78x61mm

EA DOGXL160*-7

- *: *W = white background (FSTN pos. transfective)*
E = yellow/green background (STN pos. transmissive)
B = blue background (STN neg. transmissive)
S = black background (FSTN neg. transmissive)
L = yellow/green background (STN pos. reflective, cannot be backlit)

LED BACKLIGHT, WHITE
 LED BACKLIGHT, YELLOW/GREEN
 LED BACKLIGHT, BLUE
 LED BACKLIGHT, RED
 LED BACKLIGHT, AMBER
 LED BACKLIGHT, GREEN
 LED BACKLIGHT, FULL COLOR RGB

EA LED78X64-W
 EA LED78X64-G
 EA LED78X64-B
 EA LED78X64-R
 EA LED78X64-A
 EA LED78X64-E
 EA LED78X64-RGB

ACCESSORIES

USB TEST BOARD FOR PC (WINDOWS)
 TOUCH PANEL, 4-WIRE, ANALOG, STICK-ON
 ZIF CONNECTOR FOR TOUCH PANEL, BOTTOM CONTACT
 CHARACTER SETS e.g. 6x8,8x8,8x16,CYRILLIC AND FONT EDITOR (WIN)
 SOCKET 4.8mm height (2 PCS. are required)

EA 9780-2USB
 EA TOUCH160-1
 EA WF100-04S
 EA USBSTICK-FONT
 EA FL-16P

**ELECTRONIC
 ASSEMBLY**
 making things easy

PINOUT

The EA DOGXL160, a 160x104-pixel graphics display, is a new member to ELECTRONIC ASSEMBLY's EA DOG series. It also has pins that allow it to be mounted quickly and easily.

CONTRAST ADJUSTMENT

The contrast can be set by means of a command for all the displays in the EA DOG series. The contrast setting of the display must be set once by the software, and is then kept constant throughout the entire operating temperature range (-20..+70°C), thanks to the integrated temperature compensation.

LED BACKLIGHT

7 different types are available for individual backlighting: white, yellow/green, green, blue, red, amber and a full-color version.

There are 3 separate LED paths available that can be switched in parallel or in series to suit the system voltage. To operate the yellow/green (-G), red (-R) and amber (-A) backlight, an external series resistor can be used to limit the current. This can be calculated from $R=U/I$.

To operate the white (-W), green (-E) and blue (-B) backlight, we recommend a current source (e.g. CAT4238TD).

The operating life of the yellow/green, red and amber backlights is 100,000 hours. The white, green and blue backlights we do provide with long-life LEDs from NICHIA. We recommend that you dim these or switch them off whenever possible.

Important:

Never connect the backlight LEDs directly to a 5 V/3.3 V supply as this may immediately destroy the LEDs. Always use a current limiter. Please note that derating applies at temperatures exceeding +25°C.

Pin	Symbol	Level	Function	Pin	Symbol	Level	Function
1	NC		(A1+: LED backlight)	17	VLCD	-	Power LC Drive
2	NC		(A2+: LED backlight)	18	VB0+	-	Voltage Converter
3	NC		(A3+: LED backlight)	19	VB1+	-	Voltage Converter
4				20	VB1-	-	Voltage Converter
5				21	VB0-	-	Voltage Converter
6				22	VDD	H	Power Supply +2.6..3.3V connect Pin22 <-> Pin23
7				23	VDD2/3	H	
8				24	VSS2	L	Power Supply 0V (GND) connect Pin24 <-> Pin25
9				25	VSS	L	
10				26	BM0	H / L	Config Serial Interface
11				27	CD	H / L	L= Command, H= Data
12				28	CS0/A2	L	Chip Select (active low)
13				29	RST	L	Reset (active low)
14	NC		(C1-: LED backlight)	30	D6	H / L	Config Serial Interface
15	NC		(C2-: LED backlight)	31	D3/SDA	H / L	Serial Data
16	NC		(C3-: LED backlight)	32	D0/SCK	H / L	Serial Clock

LED backlight (each path)	Forward voltage	Current	Limiting resistor (ohm)	
	typ	max	@ 3,3 V	@ 5 V
yellow/green EA LED78x64-G	1.9 V	80 mA	18	39
amber EA LED78x64-A	2.0 V	80 mA	18	39
red EA LED78x64-R	1.9 V	80 mA	18	39

LED backlight (each path)	Forward voltage	Current max.
	typ	
white EA LED78x64-W	8.8 V	20 mA
green EA LED78x64-E	9.0 V	20 mA
blue EA LED78x64-B	9.1 V	20 mA

LED backlight (each color)	Forward voltage	Current	Limiting resistor (ohm)
	typ	max	@ 5 V
full color EA LED78x64-RGB	4 V	60 mA	15

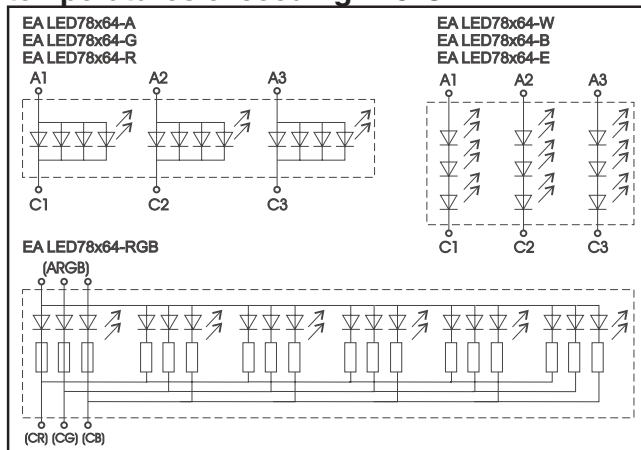



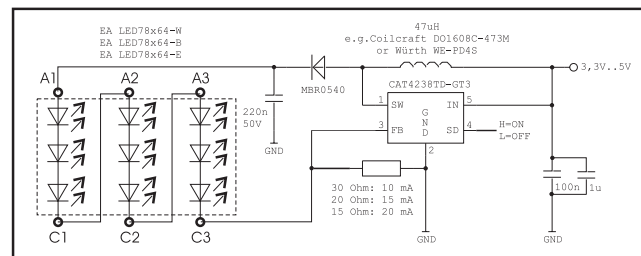

LED-Backlight schematic



Application example: EA LED78x64-W, -E, and -B

5 DIFFERENT TECHNOLOGIES

See below for an overview of available technologies, combinations with available backlights and their usability:

display type	technology	optional backlight	readability	display color non backlit	display color with backlit	recommended backlight color
	FSTN pos. transmissive	it's fine with and without backlight	readable even without backlight	black on white	black on backlight color	white, blue, green, RGB
	STN pos. yellow/green transmissive	backlight unit required	readable even without backlight	dark green on yellow/green	black on yellow/green or amber	yellow/green, amber
	STN neg. blue transmissive	usage only with backlight	---	---	backlight color on blue background	white, yellow/green
	FSTN neg. transmissive	usage only with backlight	---	---	backlight color on black background	white, green, RGB
	STN pos. yellow/green reflective	no backlight possible	finest readable without backlight	dark green on yellow/green	---	---

6 AND MORE DIFFERENT BACKLIGHTS

6 and more different backlight colors are available to match equipments design as much as possible. The most effective and brightest one is the white one EA LED68x51-W.

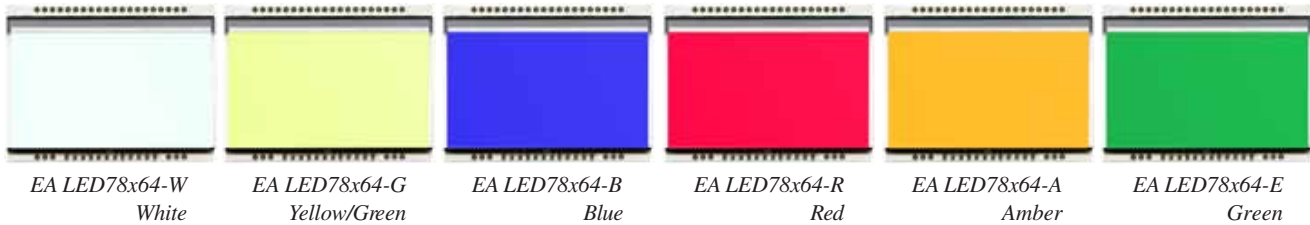

If you see black and white pictures on this page but you want to see the colors of the displays, you can download a full-colored version of this document at

<http://www.lcd-module.de/eng/pdf/grafik/dogxl160e.pdf>



EA LED78x64-RGB Full Color

DATA TRANSFER

The EA DOGXL160-7 supports four serial modes. The data transfer is unidirectional (exception I²C mode is bidirectional). That means that data can only be written; it cannot be read back. Compared to other displays, a busy query is not necessary. The clock-pulse rate of the SCL line can be up to 12 MHz at 3.3V, depending on the supply voltage and interface mode. You will find more detailed information on timing in chapter „AC CHARACTERISTICS“ of the data sheet of the UC1610 controller, which you will find on our website at <http://www.lcd-module.de/eng/pdf/zubehoer/uc1610.pdf>

Serial Modes		
BM0	D6	Description
0	0	4-wire, 8-Bit SPI
0	1	3 wire, 8-Bit SPI
1	0	3-wire, 9-Bit SPI
1	1	2-wire, I2C

4 WIRE, 8-BIT SPI-MODE

Pin CS0 is used for chip select and bus cycle reset. Pin CD is used to determine the content of the data been transferred. During each write cycle, 8 bits of data, MSB first, are latched on eight rising SCK edges into an 8-bit data holder.

If CD=0, the data byte will be decoded as command. If CD=1, this 8-bit will be treated as data and transferred to proper address in the Display Data RAM on the rising edge of the last SCK pulse.

Pin CD is examined when SCK is pulled low for the LSB (D0) of each token. The toggle of CS0 for each byte of data/command is recommended but optional. The clock-pulse rate of the SCK line can be up to 8 MHz.

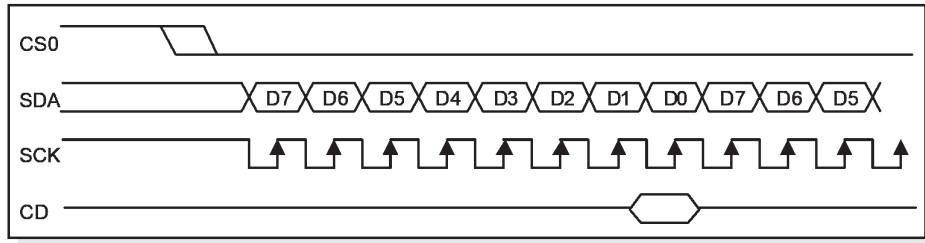
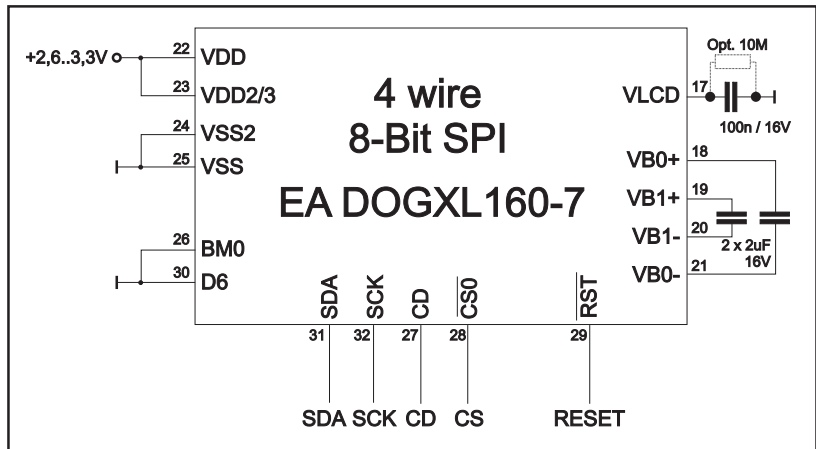

3 WIRE, 8-BIT SPI-MODE

The data format is identical to 4-wire, 8-bit SPI-mode. However in addition to CS0 pin, CD pin transitions will also reset the bus cycle in this mode. If CS0 is hardwired to enable the display, the bus can work properly with only three signal pins.

The clock-pulse rate of the SCK line can be up to 8 MHz.

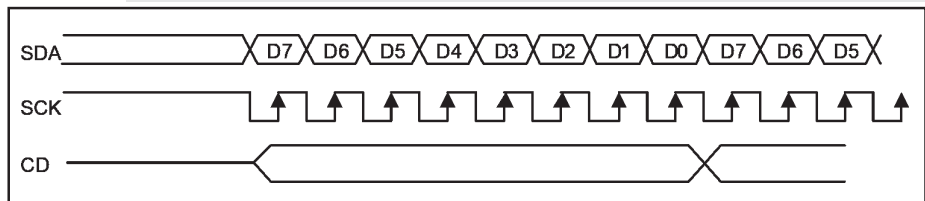
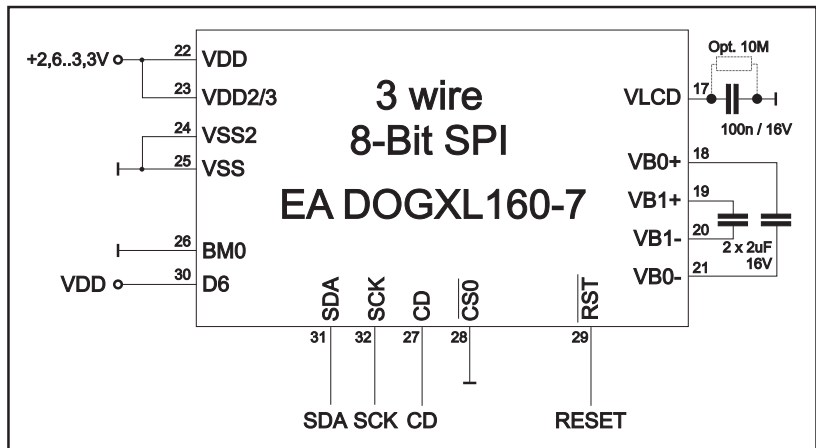

3 WIRE, 9-BIT SPI-MODE

Pin CS0 is used for chip select and bus cycle reset. On each write cycle, the first bit is CD, which determines the content of the following 8 bits of data, MSB first. These 8 command or data bits are latched on rising SCK edges into an 8-bit data holder. If CD=0, the data byte will be decoded as command. If CD=1, this 8-bit will be treated as data and transferred to proper address in the Display Data RAM at the rising edge of the last SCK pulse. The toggle of CS0 for each byte of data/command is recommended but optional. The clock-pulse rate of the SCK line can be up to 12 MHz.

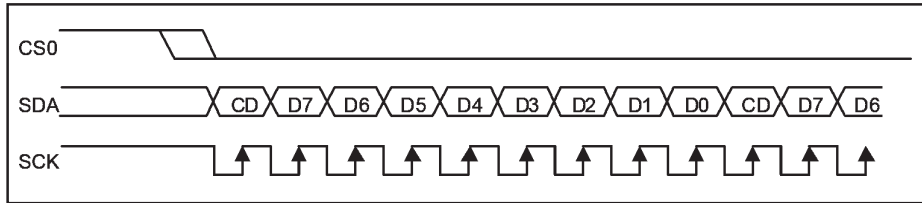
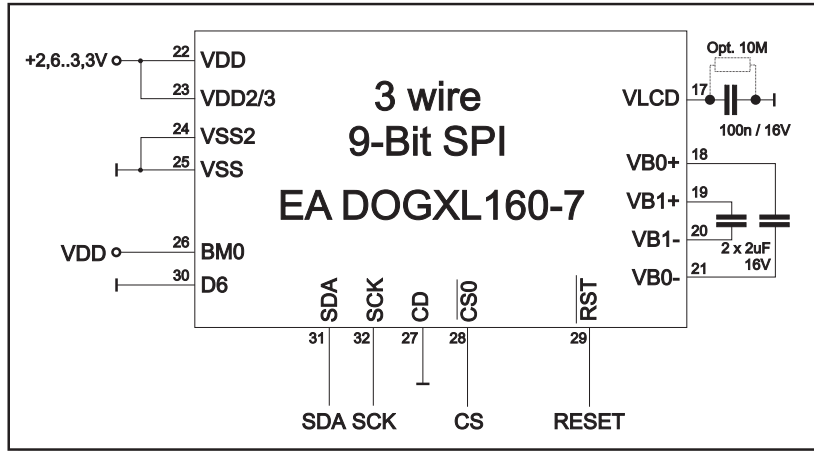

2 WIRE, I²C-MODE

Pin A2 is used to configure the device address. Each I²C sequence starts with a START condition (S) from the bus master, followed by a sequence header, containing a device address, the mode of transfer (CD: 0=Control, 1=Data), and the direction of the transfer (RW: 0=Write, 1=Read).

Note that, for data read (CD=1), the first byte of data transmitted will be dummy.

The direction (read or write) and content type (command or data) of the data bytes following each header byte are fixed for the sequence. To change the direction (R<>W) or the content type (C<>D), start a new sequence with a START (S) flag, followed by a new header.

The clock-pulse rate of the SCK line can be up to 4 MHz.

Note that, for choosing your pullups, the SDA and SCK pins do have an internal resistance of 600...1000 Ohm or more (control LO-level when reading e.g. ACK-bit).

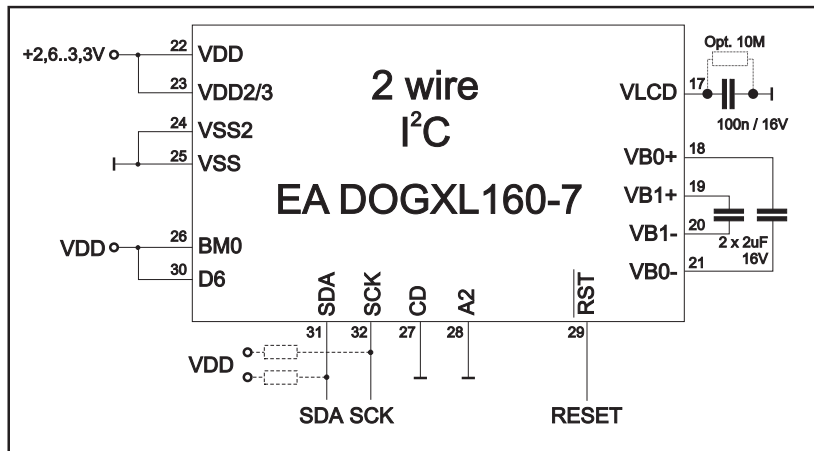

I2C-Address (A2=LO)	
Adr	Function
\$78	Write Command
\$79	Read Status
\$7A	Write Data
\$7B	Read Data

I2C-Address (A2=HI)	
Adr	Function
\$7C	Write Command
\$7D	Read Status
\$7E	Write Data
\$7F	Read Data

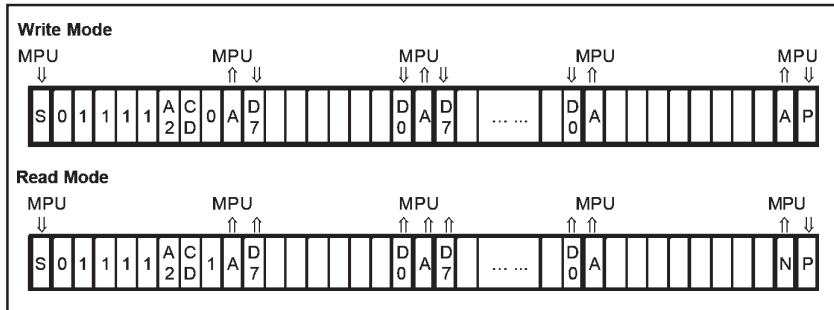

GRAPHIC RAM

The EA DOGXL160-7 has an internal RAM, each Byte represents 4 dots on display.

You will find more information in the datasheet of the UC1610 controller, which is on our website at <http://www.lcd-module.de/eng/pdf/zubehoer/uc1610.pdf>

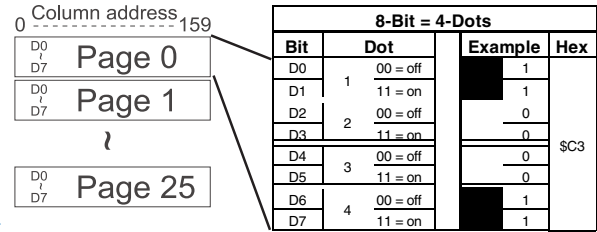

UC1610 PROGRAMMING COMMANDS (ESSENCE)

Command	Command Code										Function
	CD	D7	D6	D5	D4	D3	D2	D1	D0		
(1) Write Data Byte	1	data bit D[7..0]									Write one byte to memory
(4) Set Column Address LSB	0	0	0	0	0	CA[3..0]					Set the SRAM column address CA=0..159
		0	0	0	1	CA[7..4]					
(7) Set Page Address	0	0	1	1	PA[4..0]						Set the SRAM page address PA=0..25
(12) Set Display Enable	0	1	0	1	0	1	1	1	C2	C2=0: disable Display (sleep) C2=1: enable Display (exit from sleep)	
(13) Set RAM Address Control	0	1	0	0	0	1	AC[2..0]				AC0: 0=stop increment at end ,1=warp around AC1: 0=column, 1=page increment AC2: Set page increment: 0= +1, 1= -1
		0	0	0	0	0	1	0	0		
(30) Set Window Start Column	0	1	1	1	1	0	1	0	0	Set Start Column of Window Function	
(31) Set Window Start Page	0	1	1	1	1	0	1	0	1	Set Start Page of Window Function	
		0	0	0	0	WPP0[4..0]					
(32) Set Window End Column	0	1	1	1	1	0	1	1	0	Set End Column of Window Function	
		WPC1[7..0]									
(33) Set Window End Page	0	1	1	1	1	0	1	1	1	Set End Page of Window Function	
		0	0	0	0	WPP1[4..0]					
(34) Set Window Enable	0	1	1	1	1	1	0	0	C4	C4: 0=disable, 1=enable Window Function (disable before changing column and pages)	

INITIALISATION EXAMPLE (6 O' CLOCK)

Initialisation example (bottom view)											
Command	CD	D7	D6	D5	D4	D3	D2	D1	D0	Hex	Remark
(27) Set COM End	0	1	1	1	1	0	0	0	1	\$F1	Set last COM electrode to 103 (number of COM electrodes - 1)
		0	1	1	0	0	1	1	1	\$67	
(19) Set LCD Mapping Control	0	1	1	0	0	0	0	0	0	\$C0	SEG (column) and COM (row) normal
(9) Set Scroll Line LSB	0	0	1	0	0	0	0	0	0	\$40	Set Display Startline to 0
		0	1	0	1	0	0	0	0	\$50	
(6) Set Panel Loading	0	0	0	1	0	1	0	1	1	\$2B	Set Panelloading to 28..38nF
(24) Set LCD Bias Ratio	0	1	1	1	0	1	0	1	1	\$EB	Set Bias to 1/12
(11) Set Vbias Potentiometer	0	1	0	0	0	0	0	0	1	\$81	Set Contrast
		0	1	0	1	1	1	1	1	\$5F	
(13) Set RAM Address Control	0	1	0	0	0	1	0	0	1	\$89	Set Auto-Increment
(18) Set Display Enable	0	1	0	1	0	1	1	1	1	\$AF	Display on

12:00 VIEWING ANGLE, TOP VIEW OPTION

If the display is read mostly from above (on the front of a laboratory power supply unit, for example), the preferred angle of viewing can be set to 12 o'clock. This rotates the display by 180°. A slightly different initialization setup is required for this.



6 o'clock (Bottom View)



12 o'clock (Top View)

Initialisation example (changes for top view)											
Command	CD	D7	D6	D5	D4	D3	D2	D1	D0	Hex	Remark
(19) Set LCD Mapping Control	0	1	1	0	0	0	1	1	0	\$C6	SEG (column) and COM (row) mirror

USB-TEST BOARD EA 9780-2USB

For easy startup, an USB test board is available that can be connected to a PC. It comes with an USB cable and a Windows software. This allows text and images (BMP) to displayed directly on the plugged-in display. You will find more information on the test board in the EA 9780-2USB data sheet.



SIMULATION WITH WINDOWS

A simulator window also displays the contents of the display. The software can simulate all the displays and colors even without the hardware. You can download the software for free from our website. It runs also without the USB test board:

<http://www.lcd-module.com/produkte/dog.html>

CHARACTER SETS AND FONT EDITOR (ACCESSORY)

With the ordering code EA USBSTICK-FONT a memory stick comes with various character sets.

An import function additionally allows to use Windows fonts. With the FontEditor it is easy to generate for example Cyrillic, Greek and Arabic fonts.

The Preview function cooperates perfect with the testboard EA 9780-2USB on USB port.

TOUCH PANEL EA TOUCH160-1 (OPTIONAL)

An analogue touch panel is available as an accessory. It has a self-adhesive glue on its rear surface and is simply stuck onto the display. The connection is made by means of a 4-pin flexible cable for a ZIF connector (e.g. EA WF100-04S) with a pitch of 1.0 mm. Bending radius is defined with min. 5mm.

For optimum readability we recommend that you use a display with backlight.

Interfacing to a processor can be either done by an external touch panel controller or with a controller that is featured with analogue input lines.

The touch panel is similar to a potentiometer: connecting a voltage of e.g. 3.3V to the pins *Top-Bottom* makes it possible to read out a voltage on pin *Left* or *Right* which is linear to the Y-coordinate of the pressed point. The X-coordinate will result when the voltage will be supplied to *Left-Right* and measurement is done at *Top* or *Bottom*.

The pinout of the connecting cable is shown in the drawing.

Specification			
Specification	min	max	Unit
Top-Bottom	150	400	Ω
Left-Right	300	750	Ω
Voltage	3	12	V
Current	5	25	mA
Linearity		1,5	%
Force	45	65	g
Contact Bounce	5	10	ms
Op. Temperatur	-20	+60	$^{\circ}\text{C}$
Stor. Temperatur	-20	+70	$^{\circ}\text{C}$
Transmission	75	85	%
Life Time	100000		Cycles

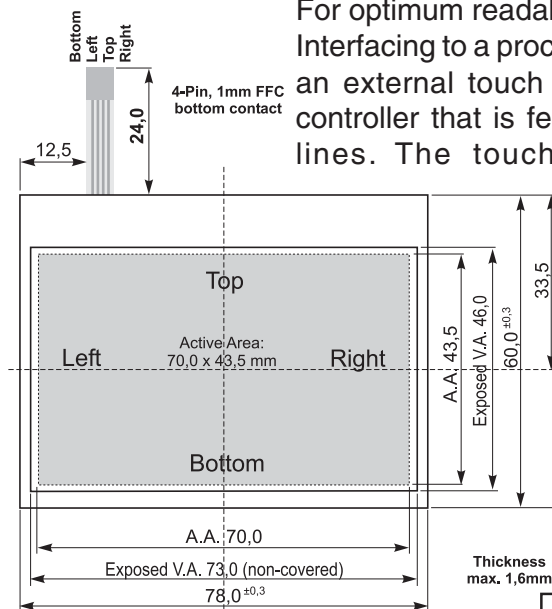

ZIF CONNECTOR EA WF100-04S

As an accessory for the touch panel we do provide a ZIF connector (4 pins) with pitch 1.0mm (SMD type). This connector is a „bottom side contact“ type.

alle dimensions are in mm

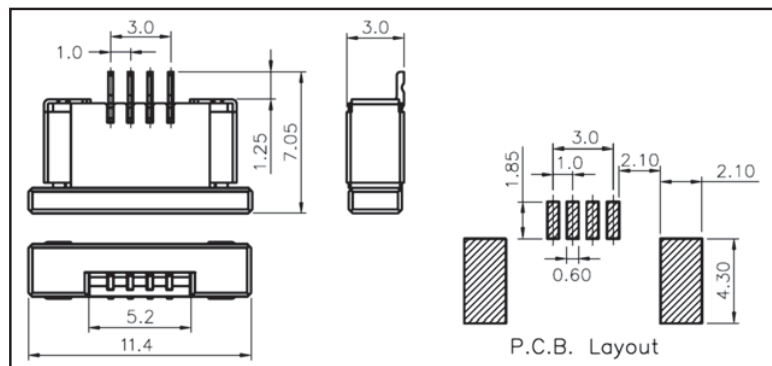

DIMENSIONS EA DOGX^L160-7

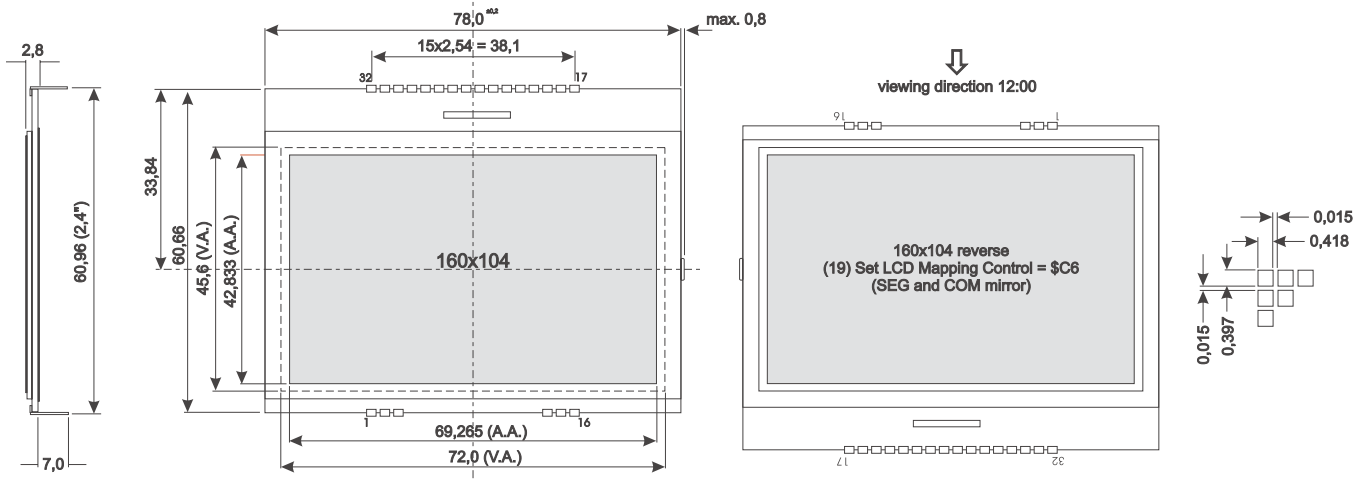

DIMENSIONS EA LED78X64

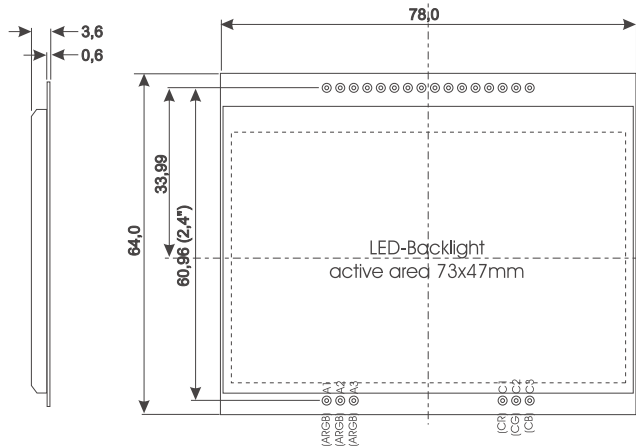

all dimensions are in mm



MOUNTING / ASSEMBLING

First, clip the display and backlight modules together by gently pushing the display pins through the corresponding holes on the backlight module. Then insert the entire module into the socket, or into the soldering holes on the pcb. The backlight pins (6 pins at the bottom) must be soldered on the top side as well to ensure good contact between the modules.

Important:

- The display has 2 protective films on the top and the bottom, and there is also one on the backlight. All these must be removed while or after assembling.
- LC displays are generally not suited for wave or reflow soldering. Temperatures of over 80°C can cause permanent damage.
- Make sure that either display nor backlight will never come into contact with any kind of liquid like Fluxer, Cleaner, Water.