

CP4 SERIES UP/DOWN COUNTER

- Backlit Green LCD or Red Illuminated Display
- Displays Actual and Preset Count
- 1/16 DIN-Sized (48 x 48mm) Housing
- Single or Dual Preset



The CP4 Series of 1/16 DIN-sized digital counters offers the choice of a large green backlit LCD display or a large red illuminated display. The CP4 Series includes one and two presets versions. The large LCD display permits easy programming and monitoring of status such as counts preset values output scaling factor. Front panel reset can be enabled or disabled. Data such as counts, preset values, setup data are saved in case of a power failure by a 10 year EEPROM memory. The front panel is rated NEMA 12.

SPECIFICATIONS:

Input Power	80 to 260 VAC 20 to 55 VAC 10 to 30 VDC
Sensor Supply	12 VDC 100 mA
Display	5 digit, Green backlit LCD 5 digit, Red Illuminated
Display digit height	8mm - actual 4mm - preset
Count Inputs	2 Inputs, IN1, IN2 Contact Closure, DC Voltage, NPN/PNP transistor Low Level: 0 to 1 VDC High Level: 4 to 30 VDC Impedance: 10 KΩ Low Speed: 30 Hz Max. High Speed: 5 kHz
Input Modes	Up IN1 - Count input DN IN1 - Count input IND IN1 - one direction IN2 - opposite direction DIR IN1 - Count input IN2 - Change in direction input CUMUL IN1 - Input IN2 - Same direction input Phase; Quadrature Up/Down Mode
Reset Input	Dry contact, voltage, solid state: NPN/PNP, front panel
Scale factor	Programmable from 0.001 to 99.999
Output	
1 Preset Version	2 Amp SP N.O. Relay 100 mA 40 VDC NPN transistor
2 Preset Version	2 x 2 Amp SP N.O. Relay
Output Modes	Repeat or single cycle Maintained or pulsed output of 500 ms
Connections	Screw terminals: 2 x 1.5mm ²
Front Panel Rating	NEMA 12, IP54

CONFORMITY:

Immunity to interference and noise (EMC)	
IEC 1000.4.2	Level 3
IEC 1000.4.3 Radiated disturbance	Level 3
IEC 1000.4.4 Fast transient	Level 3
IEC 255.4	Level 3

RF Emissions (EMC)
CENELEC EN 55022; Class A

Vibration limits (in 3 axes)
IEC 68-2-6; 10-55Hz/.0375mm

WIRING:

87 618 028 / 038 / 128 / 138
87 618 024 / 034 / 124 / 134
87 618 022 / 032 / 122 / 132

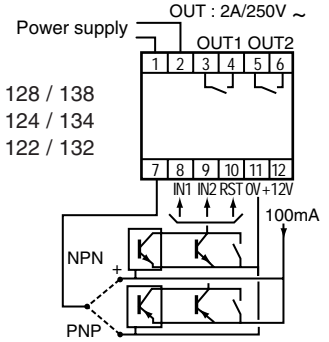

87 618 068 / 078 / 168 / 178
87 618 064 / 074 / 164 / 174
87 618 062 / 072 / 162 / 172

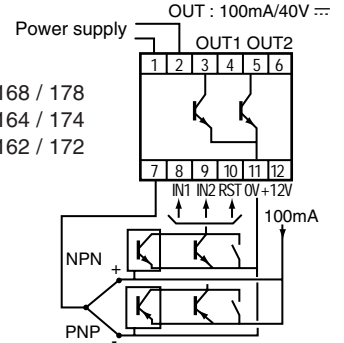

87 618 018 / 118
87 618 014 / 114
87 618 012 / 112

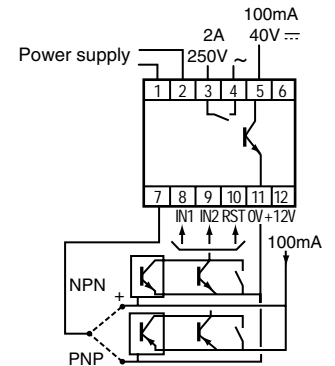

DIMENSIONS: inches (mm)

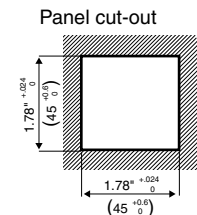
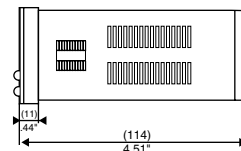
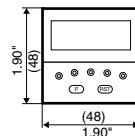

Products and specifications subject to change without notice.
Consult factory for application assistance.



Input Modes

PNP Count on rising edge
NPN Count on falling edge

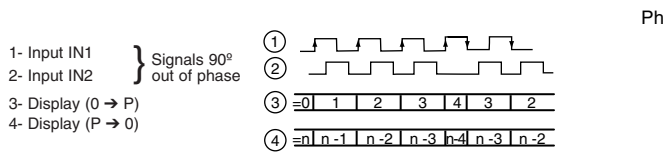
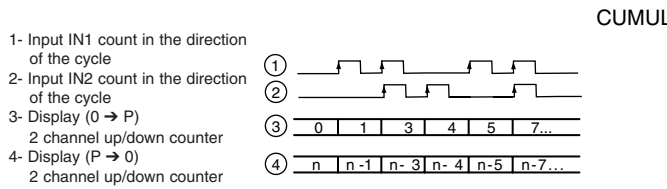
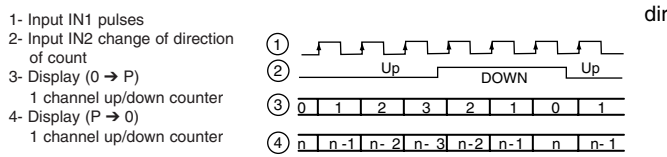
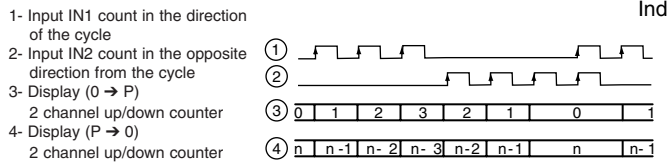
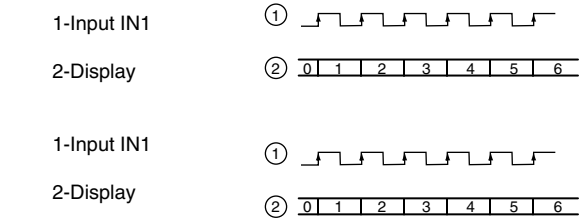

ORDERING INFORMATION

Part Number	Input Voltage	Presets	Input Modes	Display	Output
87618018	80 to 250VAC	1	UP, DN, PH	Backlit, Green	Contact and Solid State
87618014	20 to 50VAC	1	UP, DN, PH	Backlit, Green	Contact and Solid State
87618012	10 to 30VDC	1	UP, DN, PH	Backlit, Green	Contact and Solid State
87618028	80 to 250VAC	2	UP, DN, PH	Backlit, Green	Contact
87618024	20 to 50VAC	2	UP, DN, PH	Backlit, Green	Contact
87618022	10 to 30VDC	2	UP, DN, PH	Backlit, Green	Contact
87618038	80 to 250VAC	2	DR, IND, CUMUL, PH	Backlit, Green	Contact
87618034	20 to 50VAC	2	DR, IND, CUMUL, PH	Backlit, Green	Contact
87618032	10 to 30VDC	2	DR, IND, CUMUL, PH	Backlit, Green	Contact
87618118	80 to 250VAC	1	UP, DN, PH	Red Illuminated	Contact and Solid State
87618114	20 to 50VAC	1	UP, DN, PH	Red Illuminated	Contact and Solid State
87618112	10 to 30VDC	1	UP, DN, PH	Red Illuminated	Contact and Solid State
87618128	80 to 250VAC	2	UP, DN, PH	Red Illuminated	Contact
87618124	20 to 50VAC	2	UP, DN, PH	Red Illuminated	Contact
87618122	10 to 30VDC	2	UP, DN, PH	Red Illuminated	Contact
87618138	80 to 250VAC	2	DR, IND, CUMUL, PH	Red Illuminated	Contact
87618134	20 to 50VAC	2	DR, IND, CUMUL, PH	Red Illuminated	Contact
87618132	10 to 30VDC	2	DR, IND, CUMUL, PH	Red Illuminated	Contact

Output Modes

Count in the direction of the cycle ← →
Count in the opposite direction from the cycle ← →

Single Shot *PAULI*

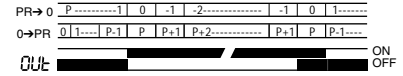

Maintained

4142/4342 - 4144/4344

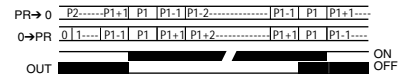

4141/4341

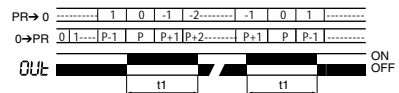

Pulsed (t=500 ms)
(transient pulse)

4142/4342 - 4144/4344

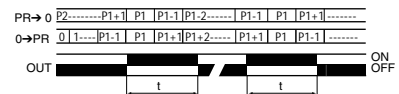

Repetitive Cycle *AUTO*

Pulsed with auto reset to value of P2 (or P for 4141/4341)
(t=500 ms)

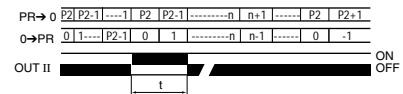

Accessory

Adaptor frame: 79 237 807 to replace 1000PA Series cutout

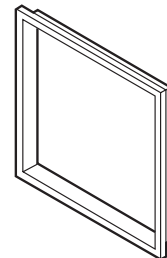

ø 49 x 50.5 mm

Products and specifications subject to change without notice.
Consult factory for application assistance.

204 Airline Drive, Suite 300, Coppell, Texas 75019 / Tel: (800) 677-5311 / FAX: (800) 677-3865 / www.crouzet-usa.com

CP4-92 SERIES

UP/DOWN COUNTER, BATCH COUNTER CHRONOMETER AND RATE CONTROLLER

- Backlit Green LCD or Red Illuminated Display
- Displays Actual and Preset Count
- 1/16 DIN-Sized (48 x 48mm) Housing



The CP4-92 Series is a programmable dual preset up/down counter, batch counter, chronometer and rate controller with relay outputs. The CP4-92 display shows both actual and preset values. Both count and preset values are saved in EEPROM memory. The unit provides a built-in sensor power supply of 12 VDC, 100mA and will accept contact or solid state inputs.

SPECIFICATIONS:

Input Power	80 to 260 VAC 20 to 55 VAC 10 to 30 VDC
Sensor Supply	12VDC 100mA
Display	5 digit, Green backlit LCD 5 digit, Red Illuminated -9999 to +99999
Display digit height	8mm - actual 4mm preset
Presets	2
Count Inputs	2 Inputs, IN1, IN2 Contact Closure, DC Voltage, NPN/PNP transistor Low Level: 0 to 1 VDC High Level: 4 to 30 VDC Impedance: 10 KΩ Low Speed: 30 Hz Max. High Speed: 5 kHz
Input Modes	Up IN1 - Count input DN IN1 - Count input IND IN1 - one direction IN2 - opposite direction DIR IN1 - Count input IN2 - Change in direction input CUMUL IN1 - Input IN2 - Same direction input Phase; Quadrature Up/Down Mode Phase x 2, Phase x 4
Reset Input	Dry contact, voltage, solid state: NPN/PNP front panel
Scale factor	Programmable from 0.001 to 99.999
Output	2 x 2 Amp SP N.O. Relay
Output Modes	Repeat or single cycle Maintained or pulsed output of 500ms.
Connections	Screw terminals: 2 x 1.5mm ²
Front Panel Rating	NEMA 12, IP54

CONFORMITY:

Immunity to interference and noise (EMC)	
IEC 1000.4.2	Level 3
IEC 1000.4.3 Radiated disturbance	Level 3
IEC 1000.4.4 Fast transient	Level 3
IEC 255.4	Level 3

RF Emissions (EMC)
CENELEC EN 55022; Class A

Vibration limits (in 3 axes)
IEC 68-2-6; 10-55Hz/.0375mm

WIRING:

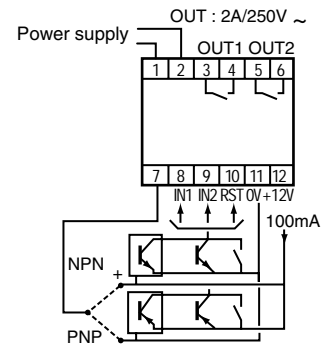

DIMENSIONS: inches (mm)

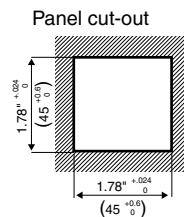
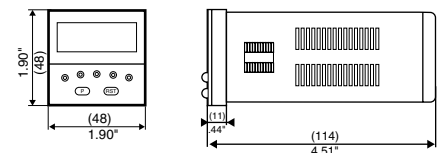

ORDERING INFORMATION:

Part Number	Input Voltage	Display
87 618 228	80 to 260 VAC	Backlit Green
87 618 224	20 to 55 VAC	Backlit Green
87 618 222	10 to 30 VDC	Backlit Green
87 618 328	80 to 260 VAC	Red Illuminated
87 618 324	20 to 55 VAC	Red Illuminated
87 618 322	10 to 30 VDC	Red Illuminated

Products and specifications subject to change without notice.
Consult factory for application assistance.



Batch counter function

Principle

P1 is the "batch" preset.

When P2 is displayed, the value displayed on the upper digits represents the current counter value (reset to P2).

In this configuration the "RST" key on the front panel reinitializes the current value.

When P1 (batch preset) is displayed, the value displayed on the upper digits represents the value of the Batch counter.

In this configuration the "RST" key on the front panel resets the batch counter.

An "electrical" reset (RST terminal) still resets the current counter value and that of the batch counter.

Example

On a packing line, bottles need to be counted into packs of 6 bottles and then dispatched in a box containing a batch of 4 packs.

P2: current counter preset value: 00006

P1: batch counter preset value: 00004



Tachometer function

Measurement principle

Measurement begins on a rising edge of the signal to be measured.

The measurement time is greater than TR, but less than TL.

Measurement stops at the end of the current period (3), after TR.

If the period (3) does not end before TL, the measurement result will be zero (0).

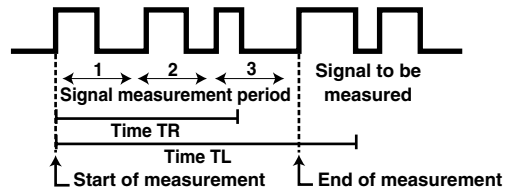

Measurement precision: $100 + (200 / TR)$ PPM

Example: for TR = 1s \rightarrow 300 PPM (0.03%)

The outputs are updated each time measurement ends according to the selected output mode.

– **Maintained output:** output active if the measured speed is greater than the preset speed.

– **Pulsed output:** output activated during time T, when the preset threshold is crossed.

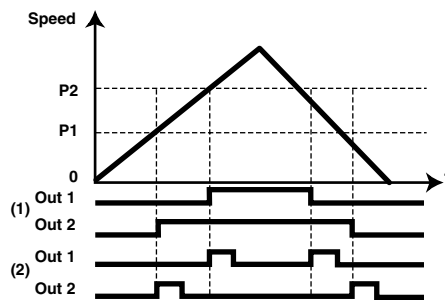
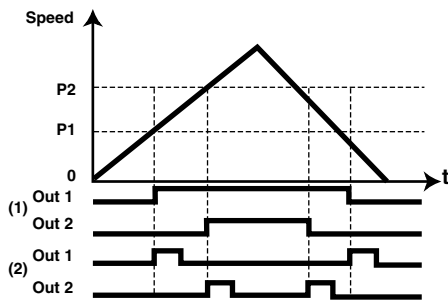

(1) Maintained output

(2) Pulsed output

Chronometer function (Precision: 150 ppm)

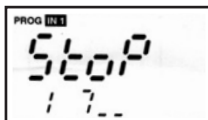

- 1 - Input IN1
- 2 - Display (0 \rightarrow PR), 1-channel pulse measurement
- 3 - Display (PR \rightarrow 0), 1-channel pulse measurement



Accessory

Adaptor frame: 79 237 807

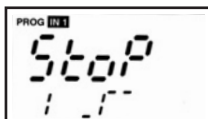

- 1 - Input IN1
- 2 - Display (0 \rightarrow PR), 1-channel pulse measurement
- 3 - Display (PR \rightarrow 0), 1-channel pulse measurement

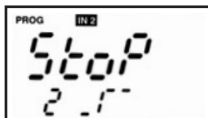
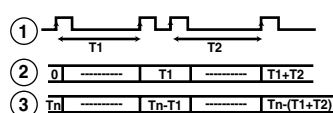

- 1 - Input IN1 (start counting)
- 2 - Input IN2 (stop counting)
- 3 - Display (0 \rightarrow PR), measurement on 2 separate channels
- 4 - Display (PR \rightarrow 0), measurement on 2 separate channels

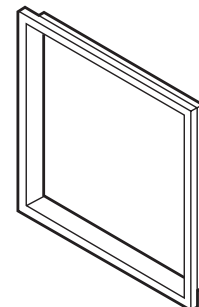
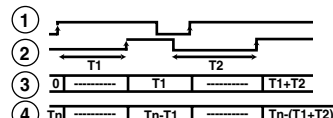

ø 49 x 50.5 mm

Products and specifications subject to change without notice.

Consult factory for application assistance.