



STD35N3LH5

N-channel 30 V, 14 mΩ, 35 A, DPAK
STripFET™ V Power MOSFET

Preliminary data

Features

Type	V _{DSS}	R _{DS(on) max}	I _D
STD35N3LH5	30 V	< 16 mΩ	35 A

- 100% avalanche tested
- Surface mounting DPAK (TO-252)
- R_{DS(on)} * Q_g industry benchmark
- Low gate drive power losses

Applications

- Switching applications
 - Automotive

Description

This STripFET™V Power MOSFET technology is among the latest improvements, which have been especially tailored to achieve very low on-state resistance providing also one of the best-in-class figure of merit (FOM).

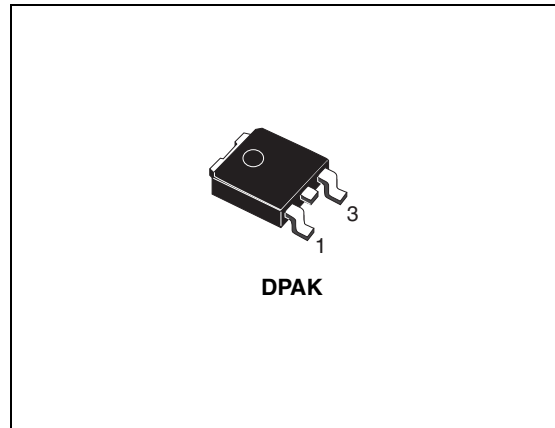

Figure 1. Internal schematic diagram

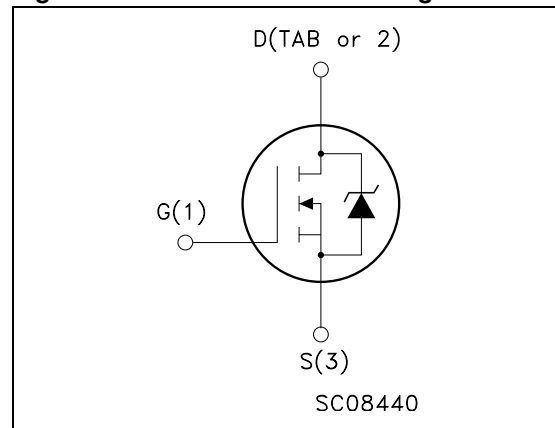

Table 1. Device summary

Order codes	Marking	Package	Packaging
STD35N3LH5	D35N3LH5	DPAK	Tape and reel

Contents

1	Electrical ratings	3
2	Electrical characteristics	4
3	Test circuits	6
4	Package mechanical data	7
5	Packaging mechanical data	9
6	Revision history	10

1 Electrical ratings

Table 2. Absolute maximum ratings

Symbol	Parameter	Value	Unit
V_{DS}	Drain-source voltage ($V_{GS}=0$)	30	V
V_{GS}	Gate-source voltage	± 20	V
I_D	Drain current (continuous) at $T_C = 25\text{ }^\circ\text{C}$	35	A
I_D	Drain current (continuous) at $T_C = 100\text{ }^\circ\text{C}$	22	A
$I_{DM}^{(1)}$	Drain current (pulsed)	140	A
P_{TOT}	Total dissipation at $T_C = 25\text{ }^\circ\text{C}$	35	W
	Derating factor	0.23	W/ $^\circ\text{C}$
$dv/dt^{(2)}$	Peak diode recovery voltage slope	TBD	V/ns
E_{AS}	Single pulse avalanche energy	TBD	mJ
T_j T_{stg}	Operating junction temperature Storage temperature	-55 to 175	$^\circ\text{C}$

1. Pulse width limited by safe operating area
2. $I_{SD} \leq 30\text{ A}$, $di/dt \leq 400\text{ A}/\mu\text{s}$, $V_{DS} \leq V_{(BR)DSS}$, $T_j \leq T_{jmax}$

Table 3. Thermal resistance

Symbol	Parameter	Value	Unit
$R_{thj-case}$	Thermal resistance junction-case max	4.3	$^\circ\text{C}/\text{W}$
$R_{thj-pcb}^{(1)}$	Thermal resistance junction-ambient max	50	$^\circ\text{C}/\text{W}$

1. When mounted on 1inch² FR-4 2Oz Cu board

2 Electrical characteristics

(T_{CASE} = 25 °C unless otherwise specified)

Table 4. Static

Symbol	Parameter	Test conditions	Min.	Typ.	Max.	Unit
V _{(BR)DSS}	Drain-source breakdown voltage	I _D = 250 μA, V _{GS} = 0	30			V
I _{DSS}	Zero gate voltage drain current (V _{GS} = 0)	V _{DS} = Max rating, V _{DS} = Max rating, T _c = 125 °C			1 10	μA μA
I _{GSS}	Gate body leakage current (V _{DS} = 0)	V _{GS} = ±20 V			±100	nA
V _{GS(th)}	Gate threshold voltage	V _{DS} = V _{GS} , I _D = 250 μA	1		2.5	V
R _{DS(on)}	Static drain-source on resistance	V _{GS} = 10 V, I _D = 15 A V _{GS} = 4.5 V, I _D = 15 A		14 18	16 20	mΩ mΩ

Table 5. Dynamic

Symbol	Parameter	Test conditions	Min	Typ.	Max.	Unit
g _{fs} ⁽¹⁾	Forward transconductance	V _{DS} = 25 V, I _D = 15 A	-	TBD		S
C _{iSS}	Input capacitance	V _{DS} = 25 V, f = 1 MHz, V _{GS} = 0	-	725		pF
C _{oSS}	Output capacitance			135		pF
C _{rSS}	Reverse transfer capacitance			20.5		pF
Q _g	Total gate charge	V _{DD} = 15 V, I _D = 11 A	-	6	TBD	nC
Q _{gs}	Gate-source charge	V _{GS} = 4.5 V		2		nC
Q _{gd}	Gate-drain charge	Figure 3		2.1		nC

1. Pulsed: pulse duration = 300 μs, duty cycle 1.5%

Table 6. Switching on/off (inductive load)

Symbol	Parameter	Test conditions	Min.	Typ.	Max.	Unit
$t_{d(on)}$ t_r	Turn-on delay time Rise time	$V_{DD}=20\text{ V}$, $I_D=15\text{ A}$, $R_G=4.7\ \Omega$, $V_{GS}=10\text{ V}$ Figure 5	-	TBD TBD	-	ns ns
$t_{d(off)}$ t_f	Turn-off delay time Fall time	$V_{DD}=20\text{ V}$, $I_D=15\text{ A}$, $R_G=4.7\ \Omega$, $V_{GS}=10\text{ V}$ Figure 5	-	TBD TBD	-	ns ns

Table 7. Source drain diode

Symbol	Parameter	Test conditions	Min.	Typ.	Max.	Unit
I_{SD}	Source-drain current		-		35	A
$I_{SDM}^{(1)}$	Source-drain current (pulsed)		-		140	A
$V_{SD}^{(2)}$	Forward on voltage	$I_{SD}=35\text{ A}$, $V_{GS}=0$	-		1.5	V
t_{rr} Q_{rr} I_{RRM}	Reverse recovery time Reverse recovery charge Reverse recovery current	$I_{SD}=35\text{ A}$, $di/dt = 100\text{ A}/\mu\text{s}$, $V_{DD}=20\text{ V}$, $T_j=150\text{ }^\circ\text{C}$ Figure 4	-	TBD TBD TBD		ns nC A

1. Pulse width limited by safe operating area
2. Pulsed: pulse duration = 300 μs , duty cycle 1.5%

3 Test circuits

Figure 2. Switching times test circuit for resistive load

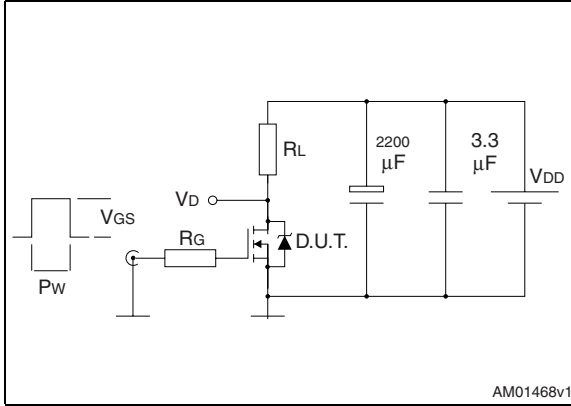

Figure 3. Gate charge test circuit

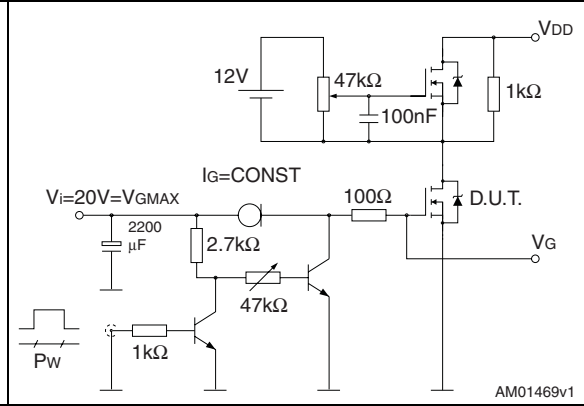

Figure 4. Test circuit for inductive load switching and diode recovery times

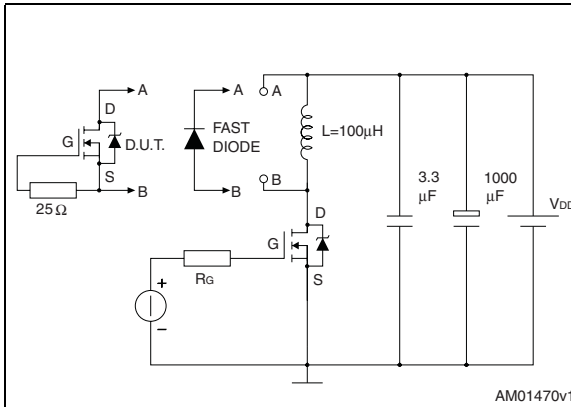

Figure 5. Unclamped inductive load test circuit

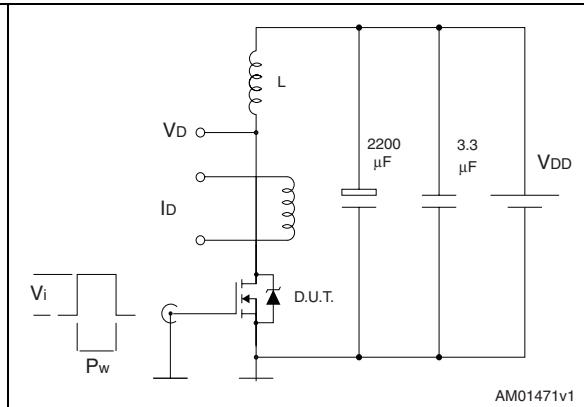

Figure 6. Unclamped inductive waveform

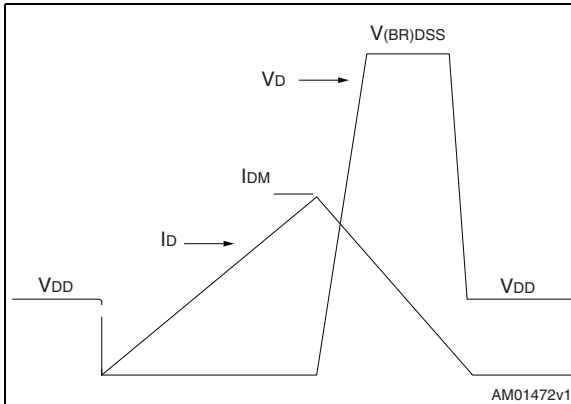
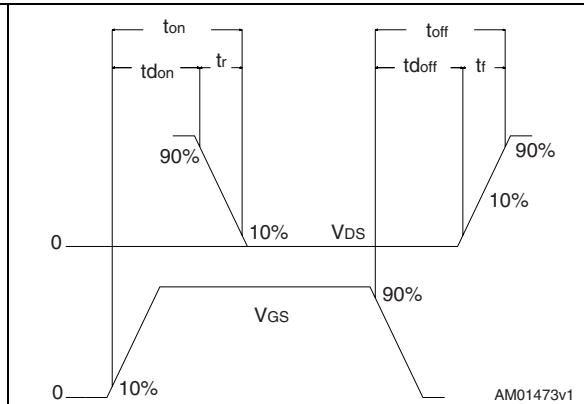

Figure 7. Switching time waveform



4 Package mechanical data

In order to meet environmental requirements, ST offers these devices in different grades of ECOPACK[®] packages, depending on their level of environmental compliance. ECOPACK[®] specifications, grade definitions and product status are available at: www.st.com. ECOPACK is an ST trademark.

TO-252 (DPAK) mechanical data

DIM.	mm.		
	min.	typ	max.
A	2.20		2.40
A1	0.90		1.10
A2	0.03		0.23
b	0.64		0.90
b4	5.20		5.40
c	0.45		0.60
c2	0.48		0.60
D	6.00		6.20
D1		5.10	
E	6.40		6.60
E1		4.70	
e		2.28	
e1	4.40		4.60
H	9.35		10.10
L	1		
L1		2.80	
L2		0.80	
L4	0.60		1
R		0.20	
V2	0°		8°

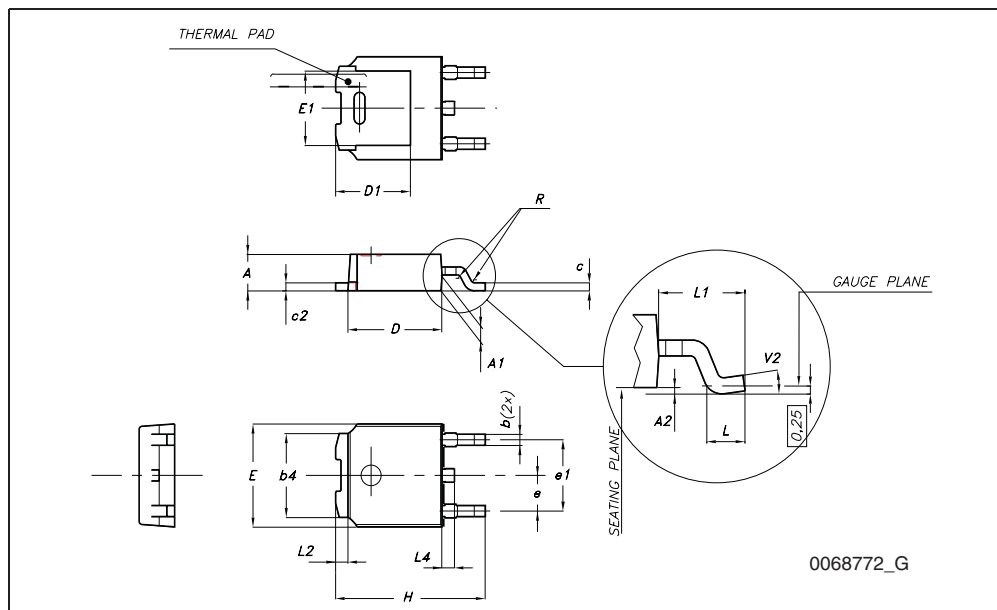

5 Packaging mechanical data

DPAK FOOTPRINT

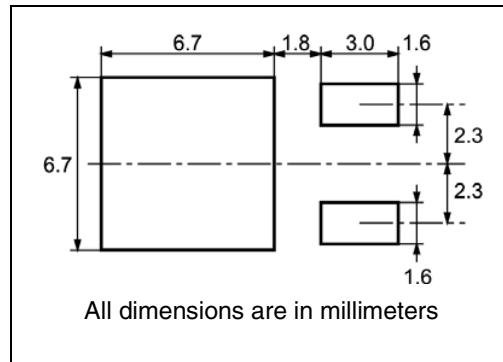

TAPE AND REEL SHIPMENT

40 mm min. Access hole at slot location

Full radius

Tape slot in core for tape start 2.5mm min. width

G measured at hub

DIM.	mm		inch	
	MIN.	MAX.	MIN.	MAX.
A		330		12.992
B	1.5		0.059	
C	12.8	13.2	0.504	0.520
D	20.2		0.795	
G	16.4	18.4	0.645	0.724
N	50		1.968	
T		22.4		0.881

BASE QTY	BULK QTY
2500	2500

DIM.	mm		inch	
	MIN.	MAX.	MIN.	MAX.
A0	6.8	7	0.267	0.275
B0	10.4	10.6	0.409	0.417
B1		12.1		0.476
D	1.5	1.6	0.059	0.063
D1	1.5		0.059	
E	1.65	1.85	0.065	0.073
F	7.4	7.6	0.291	0.299
K0	2.55	2.75	0.100	0.108
P0	3.9	4.1	0.153	0.161
P1	7.9	8.1	0.311	0.319
P2	1.9	2.1	0.075	0.082
R	40		1.574	
W	15.7	16.3	0.618	0.641

10 pitches cumulative tolerance on tape +/- 0.2 mm

Center line of cavity

User Direction of Feed

FEED DIRECTION

Bending radius

R min.

For machine ref. only including draft and radii concentric around B0

6 Revision history

Table 8. Document revision history

Date	Revision	Changes
02-Oct-2009	1	First release.

Please Read Carefully:

Information in this document is provided solely in connection with ST products. STMicroelectronics NV and its subsidiaries ("ST") reserve the right to make changes, corrections, modifications or improvements, to this document, and the products and services described herein at any time, without notice.

All ST products are sold pursuant to ST's terms and conditions of sale.

Purchasers are solely responsible for the choice, selection and use of the ST products and services described herein, and ST assumes no liability whatsoever relating to the choice, selection or use of the ST products and services described herein.

No license, express or implied, by estoppel or otherwise, to any intellectual property rights is granted under this document. If any part of this document refers to any third party products or services it shall not be deemed a license grant by ST for the use of such third party products or services, or any intellectual property contained therein or considered as a warranty covering the use in any manner whatsoever of such third party products or services or any intellectual property contained therein.

UNLESS OTHERWISE SET FORTH IN ST'S TERMS AND CONDITIONS OF SALE ST DISCLAIMS ANY EXPRESS OR IMPLIED WARRANTY WITH RESPECT TO THE USE AND/OR SALE OF ST PRODUCTS INCLUDING WITHOUT LIMITATION IMPLIED WARRANTIES OF MERCHANTABILITY, FITNESS FOR A PARTICULAR PURPOSE (AND THEIR EQUIVALENTS UNDER THE LAWS OF ANY JURISDICTION), OR INFRINGEMENT OF ANY PATENT, COPYRIGHT OR OTHER INTELLECTUAL PROPERTY RIGHT.

UNLESS EXPRESSLY APPROVED IN WRITING BY AN AUTHORIZED ST REPRESENTATIVE, ST PRODUCTS ARE NOT RECOMMENDED, AUTHORIZED OR WARRANTED FOR USE IN MILITARY, AIR CRAFT, SPACE, LIFE SAVING, OR LIFE SUSTAINING APPLICATIONS, NOR IN PRODUCTS OR SYSTEMS WHERE FAILURE OR MALFUNCTION MAY RESULT IN PERSONAL INJURY, DEATH, OR SEVERE PROPERTY OR ENVIRONMENTAL DAMAGE. ST PRODUCTS WHICH ARE NOT SPECIFIED AS "AUTOMOTIVE GRADE" MAY ONLY BE USED IN AUTOMOTIVE APPLICATIONS AT USER'S OWN RISK.

Resale of ST products with provisions different from the statements and/or technical features set forth in this document shall immediately void any warranty granted by ST for the ST product or service described herein and shall not create or extend in any manner whatsoever, any liability of ST.

ST and the ST logo are trademarks or registered trademarks of ST in various countries.

Information in this document supersedes and replaces all information previously supplied.

The ST logo is a registered trademark of STMicroelectronics. All other names are the property of their respective owners.

© 2009 STMicroelectronics - All rights reserved

STMicroelectronics group of companies

Australia - Belgium - Brazil - Canada - China - Czech Republic - Finland - France - Germany - Hong Kong - India - Israel - Italy - Japan - Malaysia - Malta - Morocco - Philippines - Singapore - Spain - Sweden - Switzerland - United Kingdom - United States of America

www.st.com

