

DO NOT SCALE DRAWING  
DIMENSION IN METRIC

DWG. NO.  
SD 35023-00

SIMILAR ITEM  
35023-00

PROJECT NO.

C

B

A

8 7 6 5 4 3 2 1

F  
E  
D  
C  
B  
A

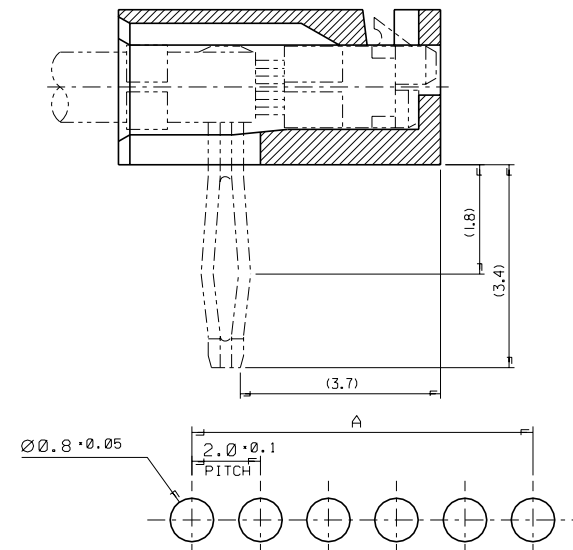
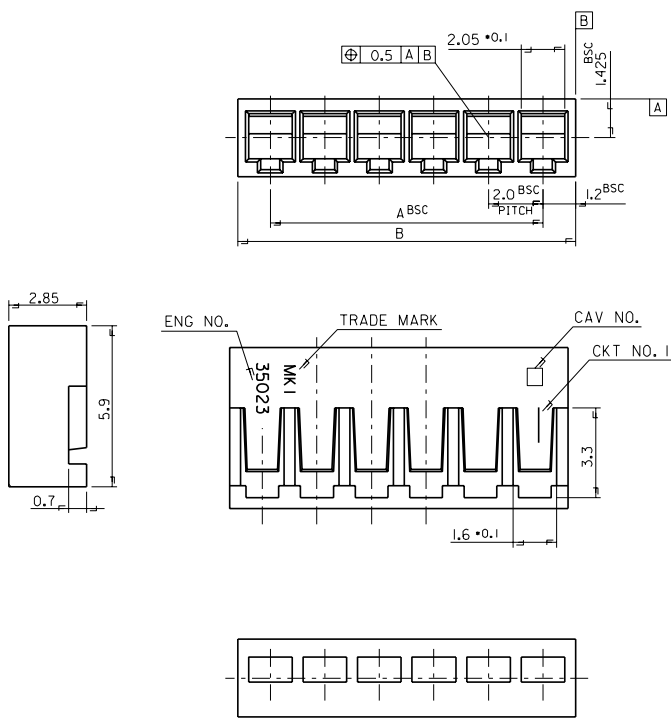

P.C. BOARD LAY OUT  
(THK. = 1.6T)

32.4	30.0	35023-016	16	18.4	16.0		-009	9
30.4	28.0	-015	15	16.4	14.0		-008	8
28.4	26.0	-014	14	14.4	12.0		-007	7
26.4	24.0	-013	13	12.4	10.0		-006	6
24.4	22.0	-012	12	10.4	8.0		-005	5
22.4	20.0	-011	11	8.4	6.0		-004	4
20.4	18.0	-010	10	6.4	4.0		-003	3
				4.4	2.0	35023-002		2
B	A	ENG NO.	CKT NO.	B	A	ENG NO.	CKT NO.	

- NOTE
- MATERIAL : NYLON 66 UL94V-0
  - APPLIED TERMINAL : 35021-1201/1301
  - PRODUCT SPECIFICATION : PS-35023

LEGEND

35023 - 00 \*\* CKT.(02,03,04....)  
COLOR : 0 --- NATURAL  
          1 ---- BLACK

REVISED EC NO. KOR1999-007 DRWN: K.S.KIM(990111) CHK: J.K.OH APPR: C.W.LEE	QUALITY SYMBOLS MAJOR = CRITICAL =	GENERAL TOLERANCES: (UNLESS SPECIFIED)		SCALE 7:1	DESIGN UNITS <input checked="" type="checkbox"/> mm <input type="checkbox"/> INCH	THIRD ANGLE PROJECTION 	DIMENSIONS: <input type="checkbox"/> mm <input type="checkbox"/> INCH <input checked="" type="checkbox"/> mm ONLY	SHT REVISE ON CAD ONLY
		4 PLACES ±0. ±. 3 PLACES ±0. ±. 2 PLACES ±0. ±. 1 PLACE ±0.3 ±.	DRAWN BY & DATE H.S.SHIN(931026) CHECKED BY & DATE J.K.OH APPROVED BY & DATE C.W.LEE	TITLE: 2.0mm PITCH B-IN CONN. HOUSING(S/T)		CAD FILENAME SD35023.DGN	MATERIAL NO. 35023-00**	DRAWING NO. SD 35023-00**
REV G	DESCRIPTION	DRAFT WHERE APPLICABLE MUST REMAIN WITHIN DIMENSIONS		THIS DRAWING CONTAINS INFORMATION THAT IS PROPRIETARY TO MOLEX INCORPORATED AND SHOULD NOT BE USED WITHOUT WRITTEN PERMISSION.				SIZE B

8 7 6 5 4 3 2 1 MX-A3

