



APPLICATION SPECIFICATION

STAC64 SYSTEM APPLICATION GUIDE

1.0 SCOPE THIS INSTRUCTION MANUAL CONTAINS SUPPLEMENTAL INFORMATION PERTAINING TO THE MOLEX STAC64 UNSEALED DUAL ROW 0.64 SERIES 34729, STAC64 UNSEALED DUAL ROW HYBRID 2.8-1.5 SERIES 31372, AND THE STAC64 HEADERS SERIES 34690, 34691



Table of Contents

- Section 1: Product Introduction
- Section 2: Product Summary
- Section 3: Connector Assembly
- Section 4: Connector Mating
- Section 5: Service Instructions

REVISION: A	ECR/ECN INFORMATION: EC No: UAU2010-1892 DATE: 2010 / 7 / 22	TITLE: <u>STAC64 SYSTEM APPLICATION GUIDE</u>	SHEET No. 1 of 15
DOCUMENT NUMBER: AS-34729-020	CREATED / REVISED BY: Chris Taylor	CHECKED BY: Brad Dick	APPROVED BY: Chris Dillon

TEMPLATE FILENAME: APPLICATION_SPEC[SIZE_A](V.1).DOC



APPLICATION SPECIFICATION

2.0 PRODUCT DESCRIPTION

FEATURES AND SPECIFICATIONS



Stackable connection system provides single and multi-pocket PCB solutions, offering a diverse range of circuit sizes and greatly reduces time-to-market by completely eliminating custom tooling

To address the growing electronic device requirements within today's vehicles, Molex has developed a modular 0.64, 1.50 and 2.80mm (.025, .059 and .110") terminal header system. The Stac64 connection system allows OEM and device manufacturers greater design flexibility to support both low-level signal requirements as well as power applications upwards of 30.0A. The Stac64 system allows automotive manufacturers to use header assemblies as stand-alone components, to gang multiple headers together to support a large range of signal and power needs for devices and modules.

The standard product line based on the 0.64mm (.025") pitch terminal includes: 8-, 12-, 16- and 20-circuit connectors in both vertical and right-angle headers supporting low-level signal requirements. An

additional 10-circuit 'power pocket' version, supporting power applications for 1.50 and 2.80mm (.059 and .110") pitch terminal systems, is available in vertical and right-angle configurations. This Stac64 is a standard product system based on USCAR-2 Class II mechanical and electrical performance characteristics for unsealed connector applications. The connectors mate to existing wire-harness connectors designed to the USCAR/EWCAP industry footprints.

The Stac64 standard product offering is currently tooled at high cavitation and is fully validated at the single-pocket level. This greatly reduces time-to-market by completely eliminating the need for additional tooling. For additional information visit: <http://www.molex.com/link/stac64.html>.

- 34690 Single Bay Vertical Headers
- 34691 Single Bay Right Angle
- 34695 Single Bay Hybrid Vertical Headers
- 34696 Single Bay Hybrid Right Angle Headers
- 34707 Ganged Multi-Bay Vertical Headers
- 34708 Ganged Multi-Bay Right Angle Headers
- 34729 8-20 Circuit Receptacle Connectors
- 31372 10 Circuit Hybrid Receptacle Assembly
- 34803 CTX64 Female Receptacle Terminals
- 33012 MX150 Female Receptacle Terminals

Features and Benefits

- Stackable connection system of readily available PCB headers ensure reduced time-to-market: engineering and validation times reduced significantly, no tooling necessary to produce custom multi-bay headers
- The 20-circuit-header housings are molded in standard USCAR color schemes for additional polarizations to match harness connector color-coding scheme for visual aid in assembly
- Pre-assembled, linear Mylar PC tail alignment strip for right-angle headers reduces PCB packaging complexity and provides space savings
- Modular-housing design with standard dovetail features molded into the housings allows headers to be ganged together in large assemblies to meet growing terminal quantity requirements
- PCB alignment posts ensure all terminals are properly aligned into PCB through-holes during assembly and retain header to PCB during assembly and solder processing
- PCB stand-offs molded into housings provide additional trace-routing real estate under the headers
- High temperature thermoplastic housings withstand infra red (IR) and wave lead-free solder processing per ES-40000-5013 Molex specification
- Pre-assembled TPA to receptacle housing shipped as single assembly provide applied labor and cost savings

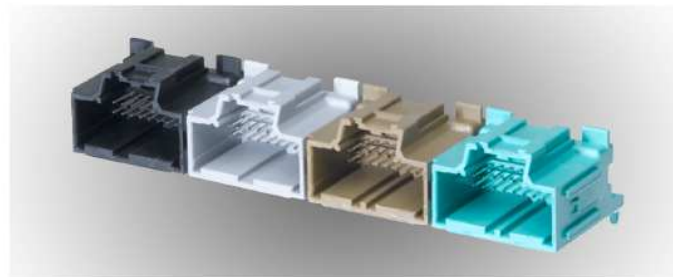

80-Circuit Right-Angle Ganged Header



20-Circuit Right-Angle Single-Bay Header - Polarization A

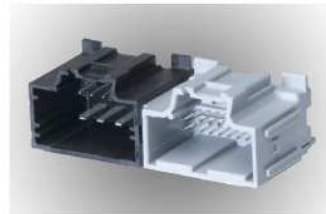

30-Circuit Ganged Vertical Header - With Power-Pocket Option

REVISION: A	ECR/ECN INFORMATION: EC No: UAU2010-1892 DATE: 2010 / 7 / 22	TITLE: STAC64 SYSTEM APPLICATION GUIDE	SHEET No. 2 of 15
-----------------------	--	--	-----------------------------

DOCUMENT NUMBER: AS-34729-020	CREATED / REVISED BY: Chris Taylor	CHECKED BY: Brad Dick	APPROVED BY: Chris Dillon
---	--	---------------------------------	-------------------------------------

TEMPLATE FILENAME: APPLICATION_SPEC[SIZE_A](V.1).DOC



APPLICATION SPECIFICATION

3.0 REFERENCE DOCUMENTS SD 34729-020, PK 31301-201, AND PS-34729-020. SD-34690-100, SD-34691-100, SD-34695-100, SD-34696-100, SD-31372-900, PS-31372-100, PK-31372-931, PS-34691-100, PS-34696-100

REVISION: A	ECR/ECN INFORMATION: EC No: UAU2010-1892 DATE: 2010 / 7 / 22	TITLE: <u>STAC64 SYSTEM APPLICATION GUIDE</u>	SHEET No. 3 of 15
DOCUMENT NUMBER: AS-34729-020	CREATED / REVISED BY: Chris Taylor	CHECKED BY: Brad Dick	APPROVED BY: Chris Dillon

TEMPLATE FILENAME: APPLICATION_SPEC[SIZE_A](V.1).DOC



APPLICATION SPECIFICATION

A. Connectors shown in "As Shipped"

Connector TPA shown in "as shipped" condition (pre-lock). The TPA must remain in the pre-lock position until all circuits are loaded.

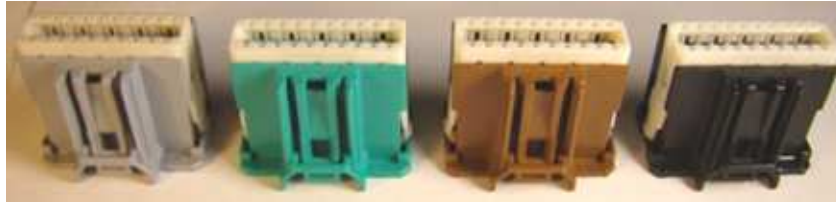

B. TPA "lift to pre-lock"

TPA must be in pre-lock position to populate the connector. If during shipping the Connector TPA moves from it's pre-lock position. Simply squeeze both sides of the TPA and slide it up the TPA will snap into pre-lock position.

If the TPA or housing is damaged in any way do not use the connector!!!

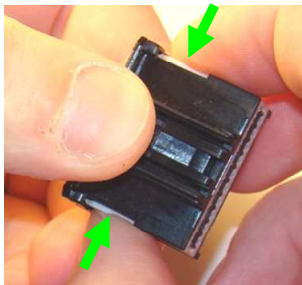

Squeeze

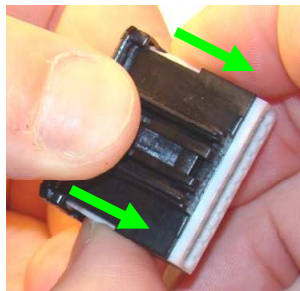

Squeeze & Slide

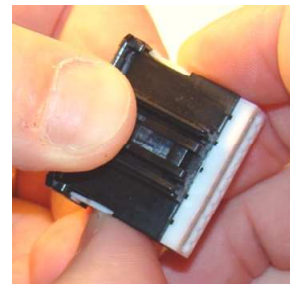

Click TPA in Pre-lock

B.(continued)TPA "lift to pre-lock" HYBRID

TPA must be in pre-lock position to populate the connector. Slide a small screwdriver Under the edge of the TPA on one side. Using the blade of the screwdriver gently push TPA upwards. Repeat this on the opposite side, TPA will snap into pre-lock position.

If the TPA or housing is damaged in any way do not use the connector!!!

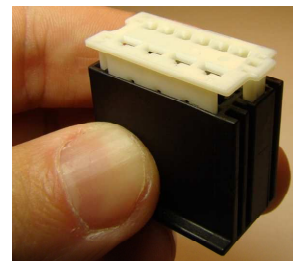
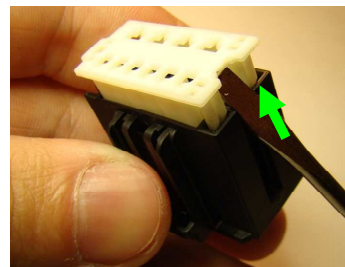
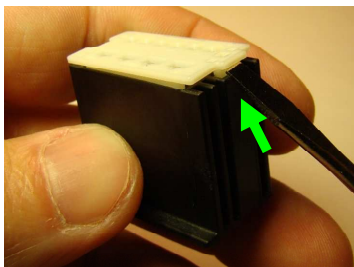

TPA in Pre-lock

REVISION: A	ECR/ECN INFORMATION: EC No: UAU2010-1892 DATE: 2010 / 7 / 22	TITLE: STAC64 SYSTEM APPLICATION GUIDE	SHEET No. 4 of 15
DOCUMENT NUMBER: AS-34729-020	CREATED / REVISED BY: Chris Taylor	CHECKED BY: Brad Dick	APPROVED BY: Chris Dillon

TEMPLATE FILENAME: APPLICATION_SPEC[SIZE_A](V.1).DOC



APPLICATION SPECIFICATION

- C. Terminal Installation:
 With TPA still in pre-lock position, orient terminal to rear of connector as shown below. Grip the wire no less than 1.25 inches from the terminal insulation crimp and insert through appropriate circuit opening. If resistance is encountered, retract the terminal and adjust the angle of insertion. Continue inserting the terminal until it stops and locks up on the lock finger with an audible click.

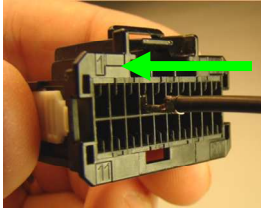

PUSH

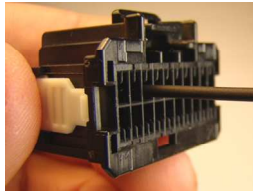

CLICK

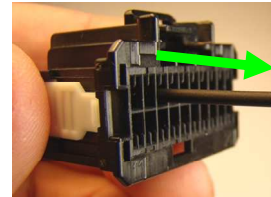

PULL

TPA must be in Pre-Lock Position to Populate Connector

- C. (continued) Terminal Installation: 1.5mm terminals is the same as above

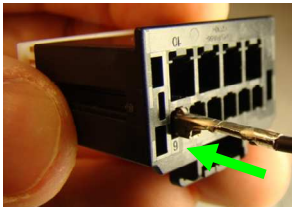

PUSH

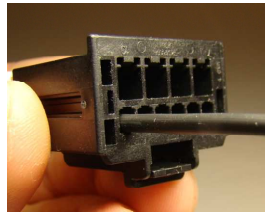

CLICK

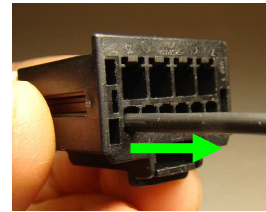

PULL

TPA must be in Pre-Lock Position to Populate Connector

- C. (continued) Terminal Installation: for 2.8 terminals is the same as above.



2.8mm terminal

PUSH

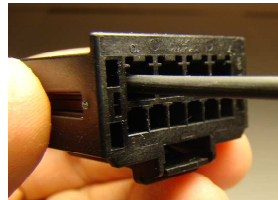

CLICK

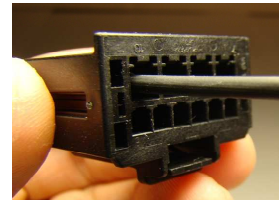

PULL

REVISION: A	ECR/ECN INFORMATION: EC No: UAU2010-1892 DATE: 2010 / 7 / 22	TITLE: STAC64 SYSTEM APPLICATION GUIDE	SHEET No. 5 of 15
DOCUMENT NUMBER: AS-34729-020	CREATED / REVISED BY: Chris Taylor	CHECKED BY: Brad Dick	APPROVED BY: Chris Dillon

TEMPLATE FILENAME: APPLICATION_SPEC[SIZE_A](V.1).DOC



APPLICATION SPECIFICATION

D. Seating the TPA

With the receptacle terminals fully installed, the TPA can be seated into its final lock position by squeezing both sides of the TPA evenly, then sliding the TPA toward the housing until it comes to a stop flush to the top of the connector housing.

Push uniformly on TPA sides to fully seat.

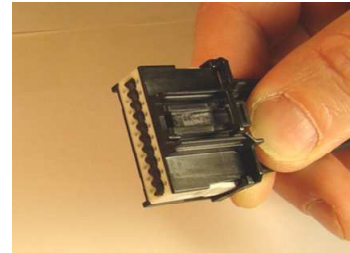
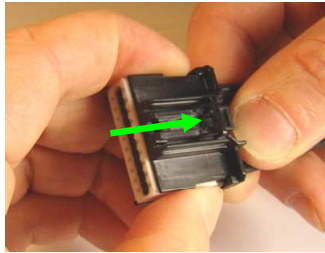
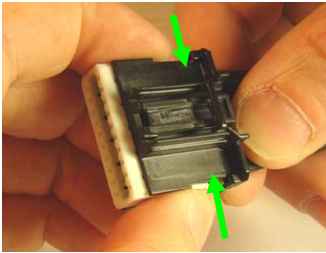

D. Seating the TPA HYBRID Connector

With the receptacle terminals fully installed, the TPA can be seated into its final lock position by applying an even force to the TPA surface until it comes to a stop, with an audible click.

Push uniformly on TPA main surface only to fully seat.

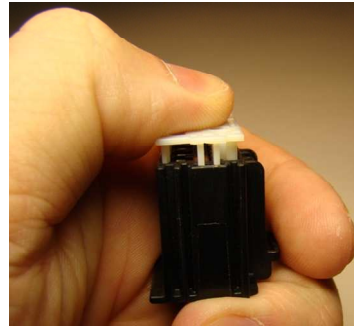

CLICK

REVISION: A	ECR/ECN INFORMATION: EC No: UAU2010-1892 DATE: 2010 / 7 / 22	TITLE: STAC64 SYSTEM APPLICATION GUIDE	SHEET No. 6 of 15
DOCUMENT NUMBER: AS-34729-020	CREATED / REVISED BY: Chris Taylor	CHECKED BY: Brad Dick	APPROVED BY: Chris Dillon

TEMPLATE FILENAME: APPLICATION_SPEC[SIZE_A](V.1).DOC



APPLICATION SPECIFICATION

A. Connector Mating

Note and align connector keying features, from receptacle connector to Mating header.

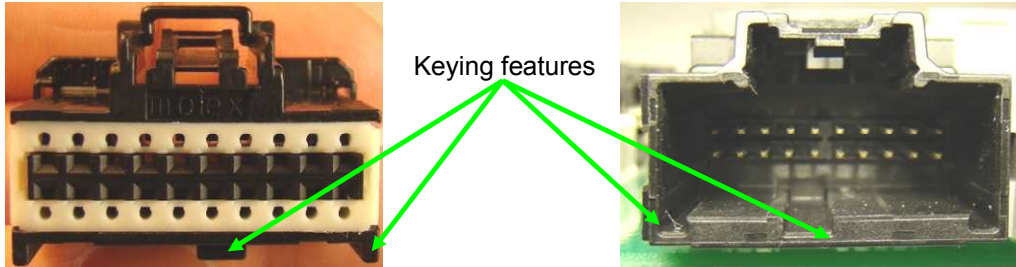

B. Begin mating procedure by sliding the receptacle connector assembly into the header assembly, press firmly until you hear an audible click.

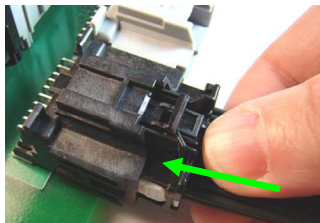

PUSH

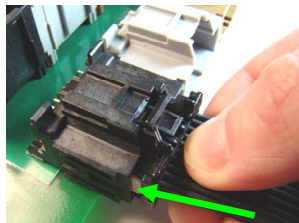

CLICK

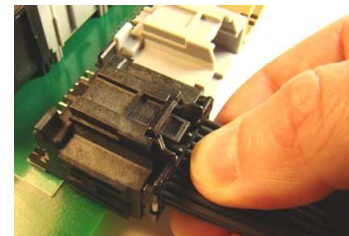

PULL

A. Connector Mating HYBRID Connector

Note and align connector keying features, from receptacle connector to Mating header.

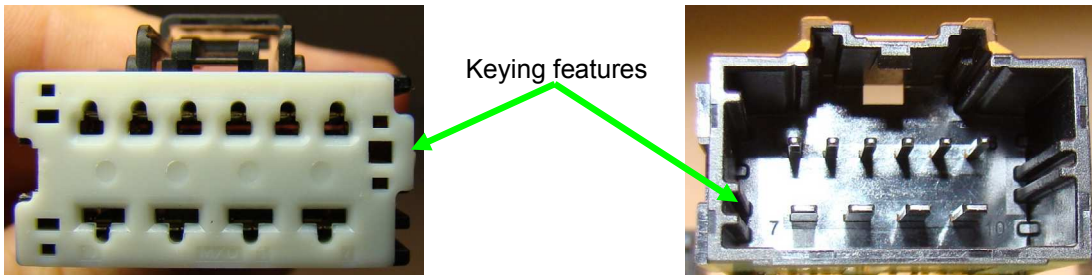

B. Begin mating procedure by sliding the receptacle connector assembly into the header assembly, press firmly until you hear an audible click.

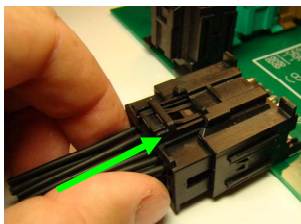

PUSH

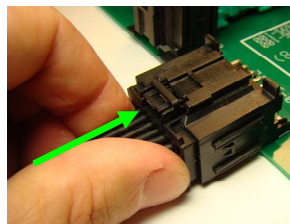

CLICK

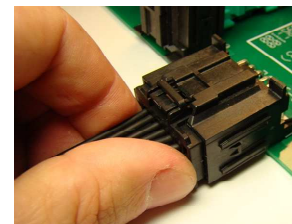

PULL

REVISION: A	ECR/ECN INFORMATION: EC No: UAU2010-1892 DATE: 2010 / 7 / 22	TITLE: STAC64 SYSTEM APPLICATION GUIDE	SHEET No. 7 of 15
DOCUMENT NUMBER: AS-34729-020	CREATED / REVISED BY: Chris Taylor	CHECKED BY: Brad Dick	APPROVED BY: Chris Dillon

TEMPLATE FILENAME: APPLICATION_SPEC[SIZE_A](V.1).DOC



APPLICATION SPECIFICATION

A. Terminal servicing

Squeeze and slide the TPA away from the housing. TPA will snap into the pre-lock position. With the TPA in pre-lock use the designated service tool, push through the service hole to disengage the lock finger. Push straight until reaching a hard stop. Once the Lock finger is disengaged, gently pull on the wire to release the terminal.

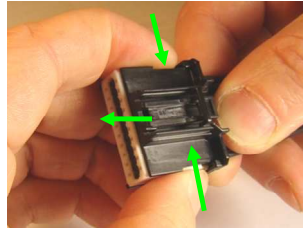
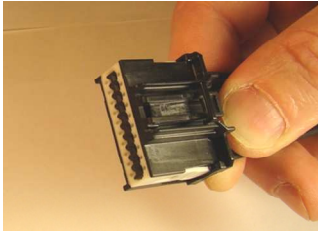

Squeeze and slide

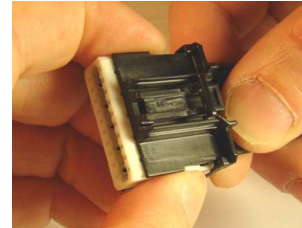

TPA in pre-lock

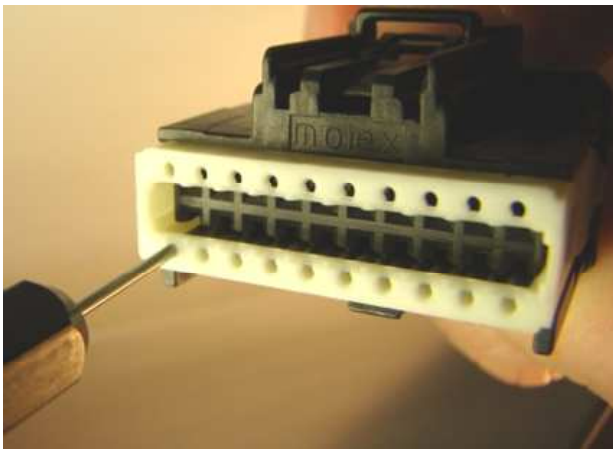

Servicing terminal

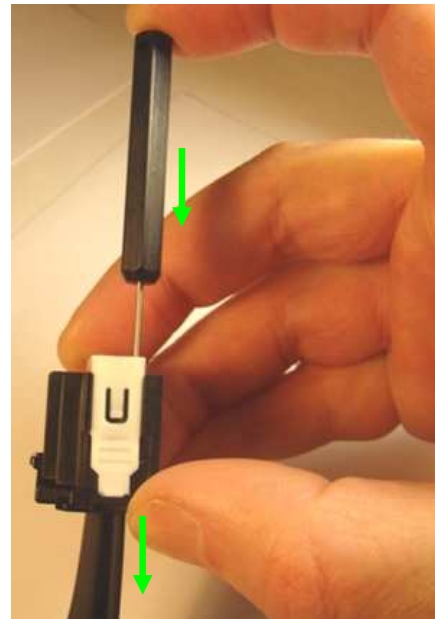

REVISION: A	ECR/ECN INFORMATION: EC No: UAU2010-1892 DATE: 2010 / 7 / 22	TITLE: STAC64 SYSTEM APPLICATION GUIDE	SHEET No. 8 of 15
DOCUMENT NUMBER: AS-34729-020	CREATED / REVISED BY: Chris Taylor	CHECKED BY: Brad Dick	APPROVED BY: Chris Dillon

TEMPLATE FILENAME: APPLICATION_SPEC[SIZE_A](V.1).DOC



APPLICATION SPECIFICATION

A. Terminal servicing HYBRID

Slide small screwdriver under the edge of the TPA on one side. Then using the blade of screwdriver, gently push TPA upwards. Repeat step 1 on opposite side.. TPA will snap into the pre-lock position.

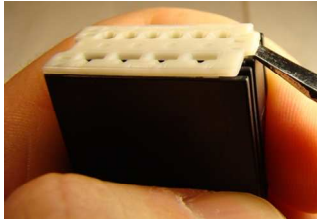

Step 1

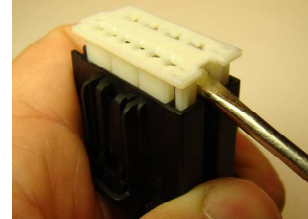
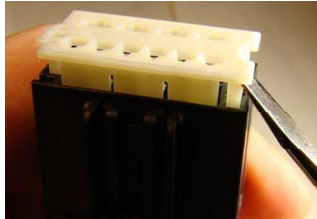

TPA in pre-lock

A. Terminal servicing (continued)

With the TPA in pre-lock use the designated service tool Molex P/N 63813-1500, push through the service hole to disengage the lock finger. Push straight until reaching a hard stop. Once the Lock finger is disengaged, gently pull on the wire to release the terminal.

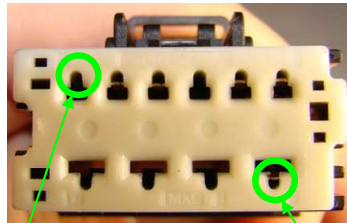
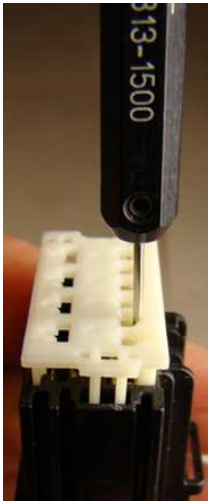

1.5mm

Service holes

2.8mm

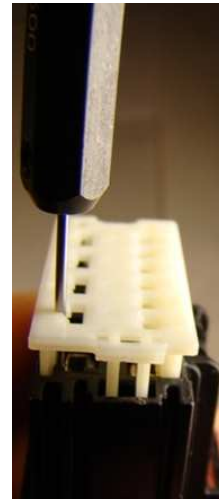

REVISION: A	ECR/ECN INFORMATION: EC No: UAU2010-1892 DATE: 2010 / 7 / 22	TITLE: STAC64 SYSTEM APPLICATION GUIDE	SHEET No. 9 of 15
DOCUMENT NUMBER: AS-34729-020	CREATED / REVISED BY: Chris Taylor	CHECKED BY: Brad Dick	APPROVED BY: Chris Dillon

B. Electrical probing, continuity checking

The preferred method of probing; use the Probe opening for receptacle terminal to check for electrical continuity.

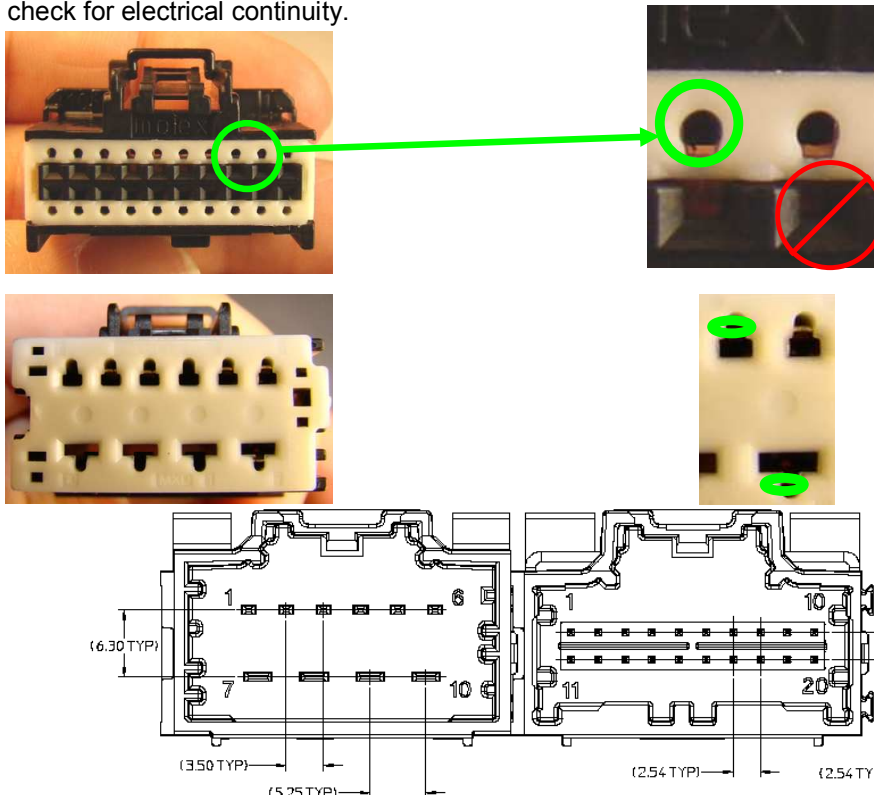

C. Electrical continuity check list

Never probe in terminal contact area

Use the designated access point.

Probe pin recommendations:

1. When testing the connector for continuity it is imperative that you do not damage the terminals!
2. Pogo pins should be checked for damage or sticking several times a shift. This should assure containment if an issue is found.
3. First a visual inspection of all the pins for damage should be performed.
4. Next a testing block should be used to depress all the pogo pins up into the barrel. If there is a bent or sticking pin, it should remain stuck in the barrel of the pogo pin. A damaged or stuck pin should be replaced before any additional testing is performed.

Probing damage can occur:

1. If a sharp ended probe is inserted into the contact of the terminal it may damage the plating and increase contact resistance
2. If an oversized diameter probe is inserted into the terminal, this will overstress the beam in the terminal. This will create an environment for intermittent connections, and increased contact resistance.
3. If a probe is inserted into the connector on an angle or off center it may damage the terminal, and or the connector.

REVISION: A	ECR/ECN INFORMATION: EC No: UAU2010-1892 DATE: 2010 / 7 / 22	TITLE: STAC64 SYSTEM APPLICATION GUIDE	SHEET No. 10 of 15
DOCUMENT NUMBER: AS-34729-020	CREATED / REVISED BY: Chris Taylor	CHECKED BY: Brad Dick	APPROVED BY: Chris Dillon



APPLICATION SPECIFICATION

4.0 PROCEDURE

4.1 GENERAL REQUIREMENTS: PLEASE SEE PK-31300-892, FOR PRODUCT SPECIFICATIONS.

4.2 ASSEMBLY INSTRUCTIONS:

WHERE FORCE NEEDS TO BE APPLIED TO SEAT HEADER TO PCB (PRESS FIT, OUTER POSTS)

NOTE: ANY PRESSURE PLACED ON THE HEADER PINS MAY DAMAGE THE ASSEMBLY

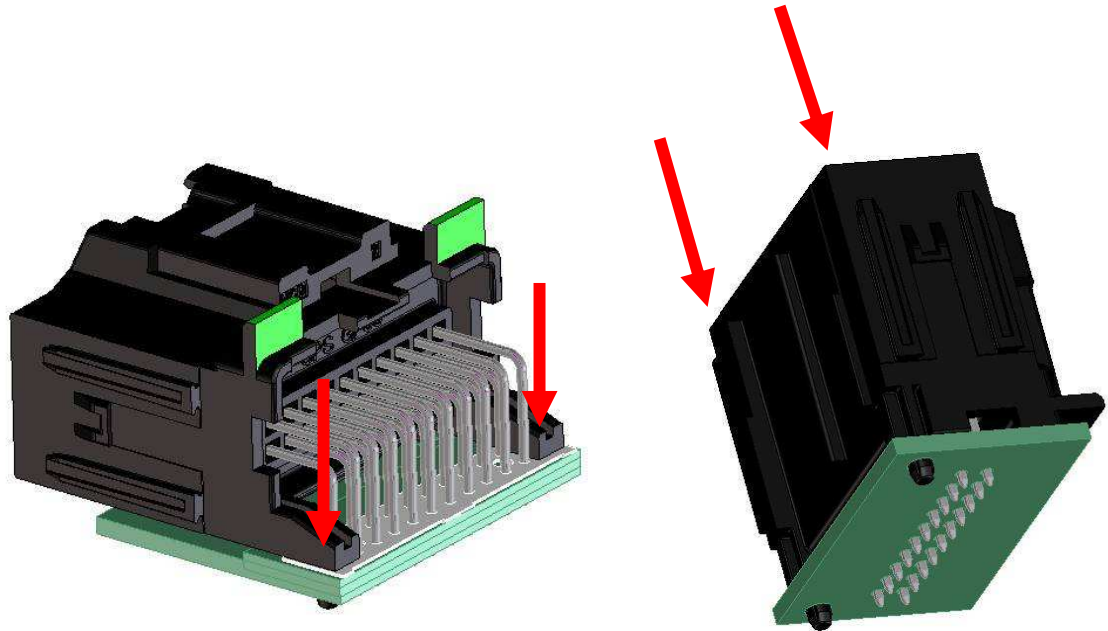

REVISION: A	ECR/ECN INFORMATION: EC No: UAU2010-1892 DATE: 2010 / 7 / 22	TITLE: STAC64 SYSTEM APPLICATION GUIDE	SHEET No. 11 of 15
DOCUMENT NUMBER: AS-34729-020	CREATED / REVISED BY: Chris Taylor	CHECKED BY: Brad Dick	APPROVED BY: Chris Dillon

TEMPLATE FILENAME: APPLICATION_SPEC[SIZE_A](V.1).DOC



APPLICATION SPECIFICATION

4.3 DRAWING DETAIL:

BELOW ARE VIEWS FROM THE 2 BAY STAC'D HEADER DRAWING. ALL 2 BAY HEADERS WILL BE COVERED BY THIS SINGLE DRAWING.

WHEN LOOKING AT THE FRONT (MATE) SIDE OF THE HEADER IT CAN BE DETERMINED WHAT HEADER BAY'S ARE IN WHAT LOCATIONS. THE BAY LETTER REFERENCES (BAY 'A', BAY 'B', ECT.) ARE LOCATIONS ONLY AND DO NOT REPRESENT ANY PARTICULAR CIRCUIT SIZE OR KEY OPTION.

2 BAY STAC64 RIGHT ANGLE HEADER ASSEMBLY
(P/N: 34708-2012 SHOWN)

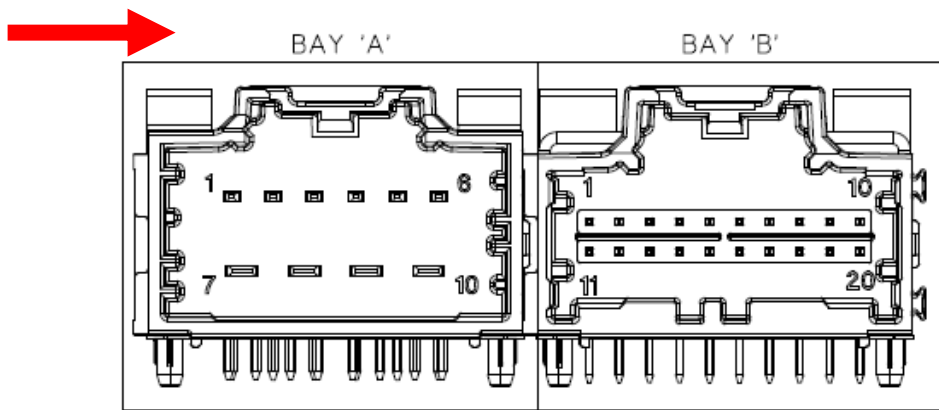

DIMENSIONAL CHART FOR MULTIBAY CONFIGURATION:

2 BAY PART NUMBER	BAY A			BAY B			DIM 'A'	DIM 'B'	DIM 'C'	DIM 'D'
	CKT	TYPE	POL	CKT	TYPE	POL				
34708-2000	20	0.64mm	A	20	0.64mm	B	66.94	64.47	27.94	27.94
34708-2012	10	HYBRID	A	20	0.64mm	C	66.94	64.47	27.94	27.94
34708-2022	20	0.64mm	C	10	HYBRID	A	66.94	64.47	27.94	27.94

THE HEADER 'BAY ID' SECTION ON THE CHART CORRESPONDS WITH THE LOCATION ON THE FRONT VIEW OF THE HEADER.

REVISION: A	ECR/ECN INFORMATION: EC No: UAU2010-1892 DATE: 2010 / 7 / 22	TITLE: STAC64 SYSTEM APPLICATION GUIDE	SHEET No. 12 of 15
DOCUMENT NUMBER: AS-34729-020	CREATED / REVISED BY: Chris Taylor	CHECKED BY: Brad Dick	APPROVED BY: Chris Dillon



APPLICATION SPECIFICATION

RECOMMENDED HEADER MOUNTING STRATEGIES (RIGHT ANGLE HEADER ONLY):

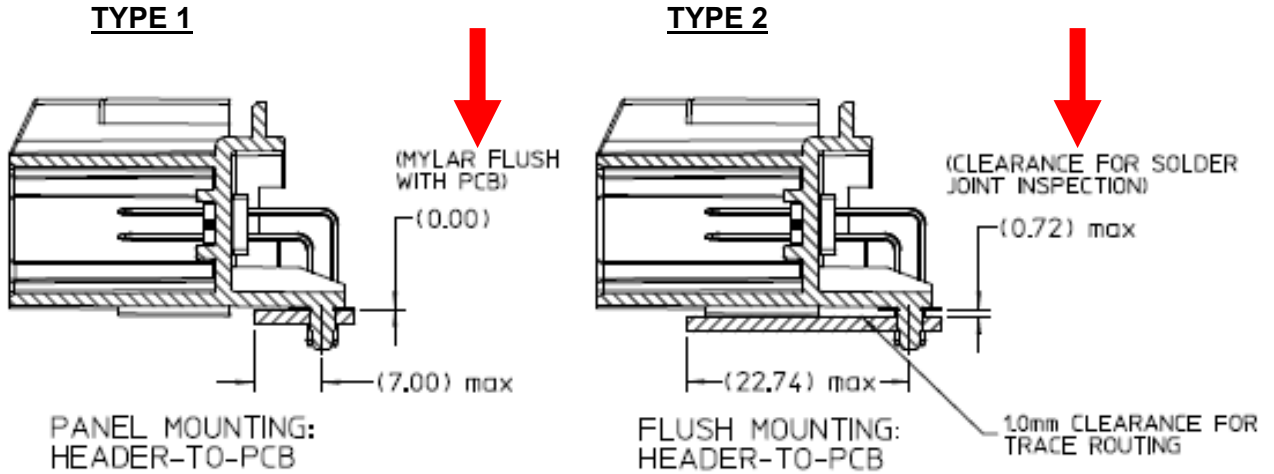

- TYPE 1:** THE BOTTOM STANDOFF RIBS ARE NOT USED. THE HEADER(S) RESTS FLAT ON THE PCB.
- TYPE 2:** THE RIBS ON THE BOTTOM OF THE PART(S) REST ON THE PCB ALLOWING FOR SOLDER JOINT INSPECTION AFTER SOLDERING.

BUILDING OF A PRINTED CIRCUIT BOARD LAYOUT:

NOTE: THE SAME BAY ID MUST BE USED FROM THE CHART ON PAGE 1.

1. REFERENCE CHART ON PAGE 1 FOR WHAT CIRCUIT SIZE AND TYPE OF HEADER GO IN EACH 'BAY' LOCATION.

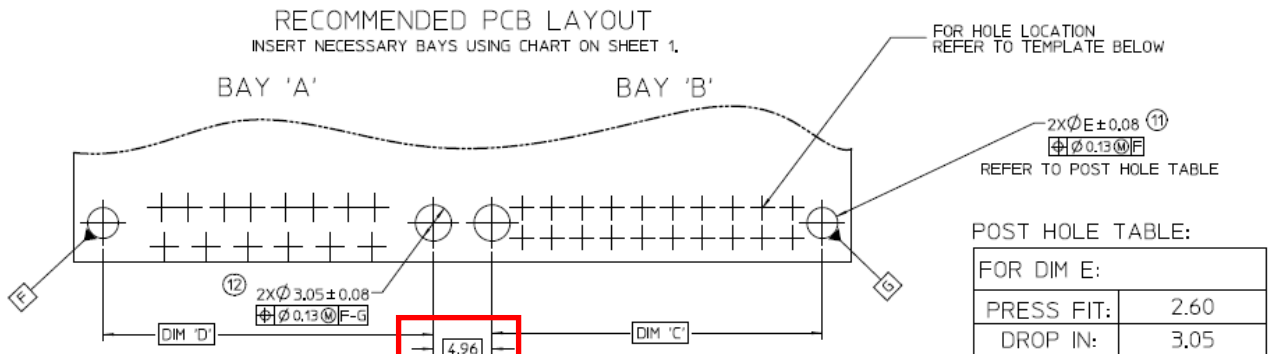

2. DETERMINE IF HEADER MUST BE DROP IN CAPABLE OR IF PRESS FIT IS ACCEPTABLE. PRESS FIT IS RECOMMENDED AND WILL RETAIN HEADER DURING PROCESSING.

REVISION: A	ECR/ECN INFORMATION: EC No: UAU2010-1892 DATE: 2010 / 7 / 22	TITLE: STAC64 SYSTEM APPLICATION GUIDE	SHEET No. 13 of 15
DOCUMENT NUMBER: AS-34729-020	CREATED / REVISED BY: Chris Taylor	CHECKED BY: Brad Dick	APPROVED BY: Chris Dillon

TEMPLATE FILENAME: APPLICATION_SPEC[SIZE_A](V.1).DOC



APPLICATION SPECIFICATION

3. USING THE SINGLE HEADER LAYOUTS BELOW BUILD THE PCB LAYOUT OF THE MULTI-BAY HEADER BY SPACING ADJACENT POST HOLES AT 4.96mm.

KEEP OUT AREAS (RIGHT ANGLE HEADERS)

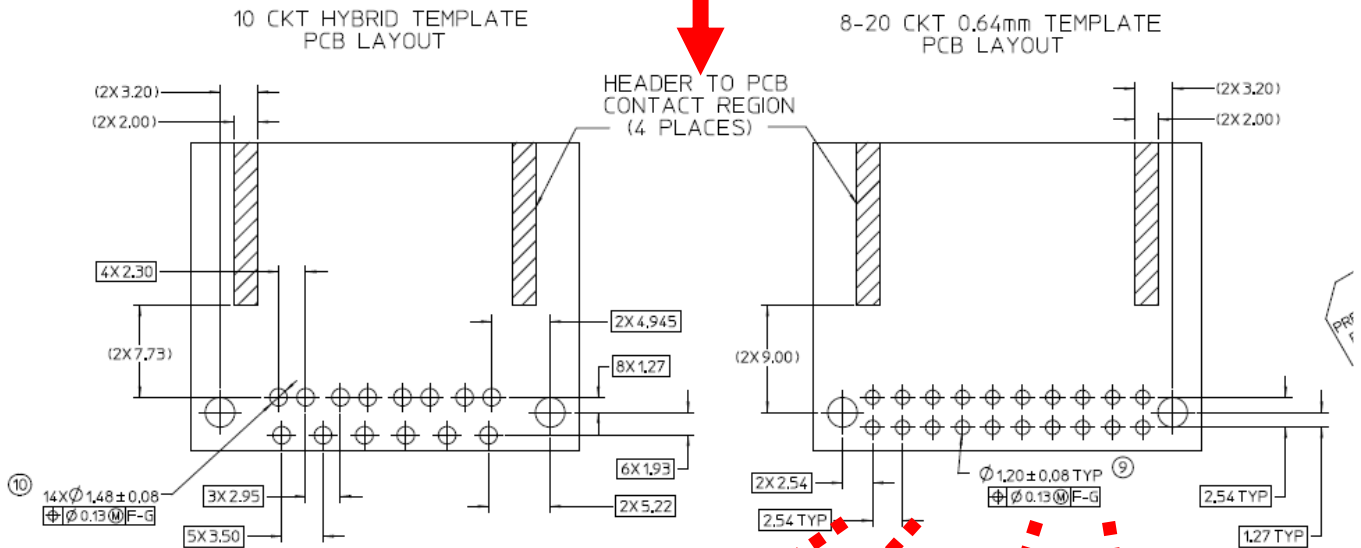

4. PLACE NECESSARY PCB LAYOUT IN EACH 'BAY' LOCATION AT 4.96mm SPACING.

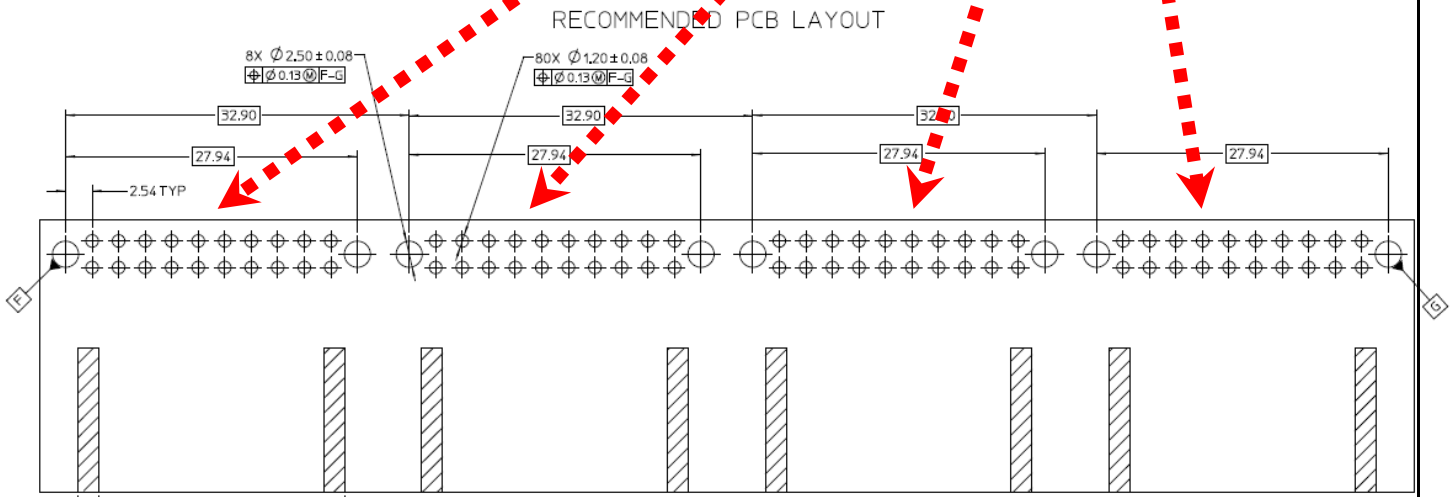

80CKT - 4 BAY HEADER FOOT PRINT - 20X20X20X20

REVISION: A	ECR/ECN INFORMATION: EC No: UAU2010-1892 DATE: 2010 / 7 / 22	TITLE: STAC64 SYSTEM APPLICATION GUIDE	SHEET No. 14 of 15
DOCUMENT NUMBER: AS-34729-020	CREATED / REVISED BY: Chris Taylor	CHECKED BY: Brad Dick	APPROVED BY: Chris Dillon

TEMPLATE FILENAME: APPLICATION_SPEC[SIZE_A](V.1).DOC



APPLICATION SPECIFICATION

5.0 PROCEDURE

4.4 GENERAL REQUIREMENTS

4.5 ASSEMBLY INSTRUCTIONS

4.6 REMOVAL INSTRUCTIONS

REVISION: A	ECR/ECN INFORMATION: EC No: UAU2010-1892 DATE: 2010 / 7 / 22	TITLE: <u>STAC64 SYSTEM APPLICATION GUIDE</u>	SHEET No. 15 of 15
DOCUMENT NUMBER: AS-34729-020	CREATED / REVISED BY: Chris Taylor	CHECKED BY: Brad Dick	APPROVED BY: Chris Dillon

TEMPLATE FILENAME: APPLICATION_SPEC[SIZE_A](V.1).DOC