

# HC-A3-STQ1,5-KML-G-PA

Order No.: 1641604



<http://eshop.phoenixcontact.de/phoenix/treeViewClick.do?UID=1641604>

HEAVYCON QUICKON coupling housing A3, for single locking latch, 3-pos., with PE connection, plug , QUICKON connection, straight cable outlet

Commercial data	
GTIN (EAN)	 4 017918 890001
sales group	D442
Pack	1 pcs.
Customs tariff	85369010
Catalog page information	Page 421 (PC-2009)

**Product notes**

WEEE/RoHS-compliant since:  
03/28/2006



<http://www.download.phoenixcontact.com>  
Please note that the data given here has been taken from the online catalog. For comprehensive information and data, please refer to the user documentation. The General Terms and Conditions of Use apply to Internet downloads.

Technical data	
General characteristics	
Connection	If the conductor is reconnected, it must be cut off above the last contact point. QUICKON components may only be operated when under no load.
Type	Male

---

Design	A3
Housing type	Coupling housings
Locking type	With single locking latch
Number of positions	3
Wrench size, union nut	19 mm
Tightening torque, union nut	3 Nm
Conductor cross section stranded min.	0.75 mm <sup>2</sup>
Conductor cross section stranded max.	1.5 mm <sup>2</sup>
Conductor cross section AWG/kcmil min.	18
Conductor cross section AWG/kcmil max	16

**Conductor data**

Structure of individual litz in acc. with VDE 0295 / smallest wire diameter	VDE 0295 Cl.2-5, min. wire diameter 0.2 mm
Wire insulation material	PVC/PE
Wire diameter including insulation	1.8 mm ... 3 mm
External cable diameter	6 mm ... 12 mm

**Environmental conditions**

Degree of protection	IP65
Ambient temperature (operation)	-25 °C ... 80 °C
Ambient temperature (storage/transport)	-40 °C ... 70 °C
Temperature when conductor connected	-5 °C ... 50 °C (specifications of the cable manufacturer must also be observed)

**Electrical characteristics**

Rated current	10 A
Note on the rated voltage (III/3)	250 / 400 V
Rated voltage (III/2)	320 V
Rated voltage (II/2)	630 V
Rated surge voltage (III/3)	4 kV
Rated surge voltage (III/2)	4 kV
Rated surge voltage (II/2)	4 kV

**Mechanical characteristics**

QUICKON connectability	10 (For the same conductor cross section)
Insertion/withdrawal cycles	500

**Material data**

Contact material	Cu alloy
Contact surface material	Silver-plated
Contact carrier material	PA / PC
Insulating material	PA
Inflammability class acc. to UL 94	V0
Surge voltage category	III
Pollution degree	3

**Certificates / Approvals**



Certification CUL, GOST, UL

**Accessories**

Item	Designation	Description
<b>General</b>		
1642182	Q 1,5/4IDC/24-24KU-KU BK PE	QUICKON cable connector, black, 3+PE-pos., 0.75 mm <sup>2</sup> ... 1.5 mm <sup>2</sup> /500 V/15 A, for a cable diameter of 6 mm ... 12 mm.
<b>Tools</b>		
1205862	MICROFOX SC	Diagonal cutter for Cu wire up to 1.5 mm diameter
1670895	QSS 19	Socket wrench, for tightening and unscrewing the QUICKON union nut, wrench size 19 mm

Diagrams/Drawings

Diagram

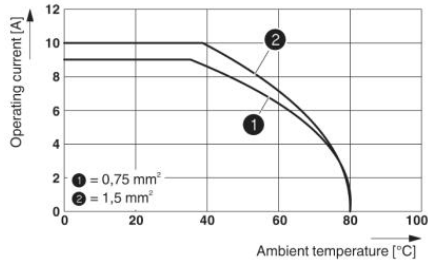

Derating diagram: A series

Dimensioned drawing

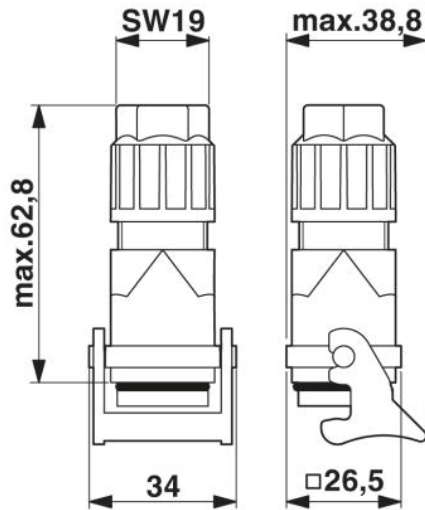

**Address**

PHOENIX CONTACT Inc., USA  
586 Fulling Mill Road  
Middletown, PA 17057, USA  
Phone (800) 888-7388  
Fax (717) 944-1625  
<http://www.phoenixcon.com>



© 2010 Phoenix Contact  
Technical modifications reserved;