

# PocketProjector

Quick Start Guide

3M™ MPro**150**

**3M**



## Parts

- 1 Directional Pad
- 2 OK Button
- 3 Back Button
- 4 Power Button
- 5 Micro SD Card Slot
- 6 Status Indicator
- 7 Focus Wheel
- 8 Lens
- 9 Speaker
- 10 DC Power Input
- 11 Micro-USB Port
- 12 Headphone Jack
- 13 VGA-AV Input
- 14 Battery Cover
- 15 Tripod Socket
- 16 Flip Stand

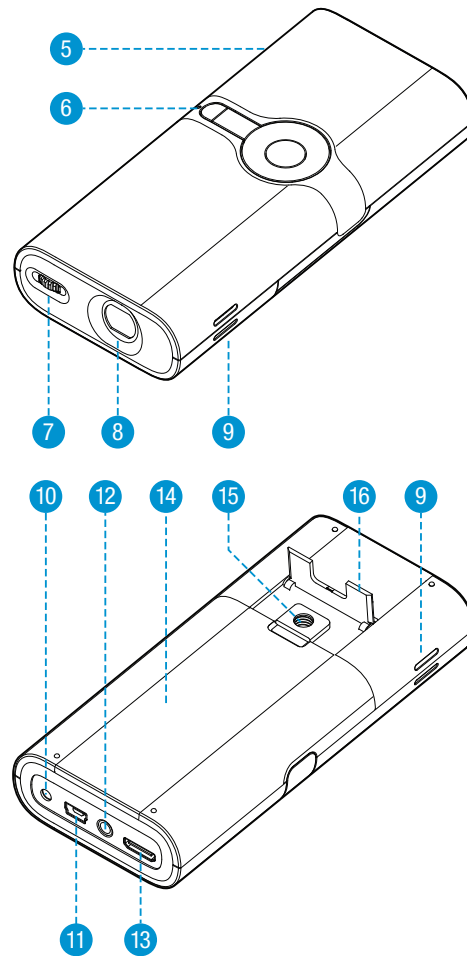
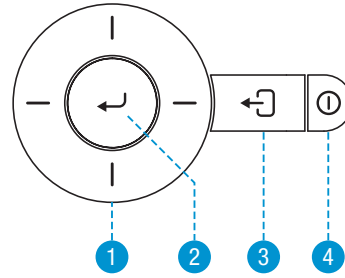

## Read Safety Guide First

**Lire d'abord le manuel de sécurité • Zuerst die Sicherheitshinweise lesen**  
**Lea la Guía de Seguridad primero • Prima leggere la guida per la sicurezza**  
**Lees eerst de veiligheidsgids • Läs säkerhetsguiden först**  
**首先要阅读安全指南 • 先閱讀工安指南 • 安全ガイドを最初に読んでください。**





3M™ Pocket Projector MPro150

## Install the Battery

Installation de la batterie • Akku installieren •  
Instalar la batería • Installare la batteria •  
De accu installeren • Installera batteriet •  
安装电池 • 安裝電池 • 電池の取り付け

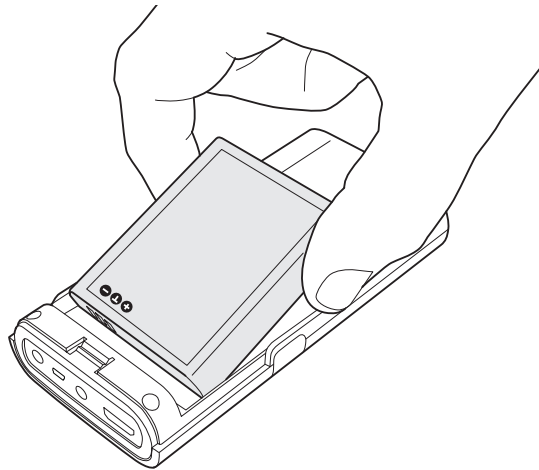
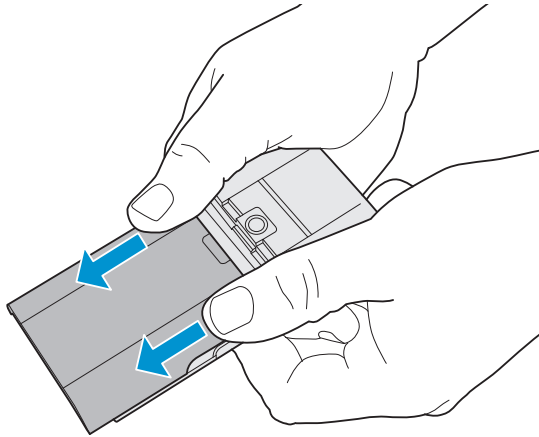

## Assemble the Power Adapter

Assemblage du bloc secteur • Zusammenbau des  
netzteils • Ensamble el adaptador de alimentación  
• Montare l'alimentatore • Montage van de  
stroomadapter • Sätt ihop strömadaptren •  
组装该 电源适配器 • 裝配電源轉換器 •  
の組立て ACアダプタ

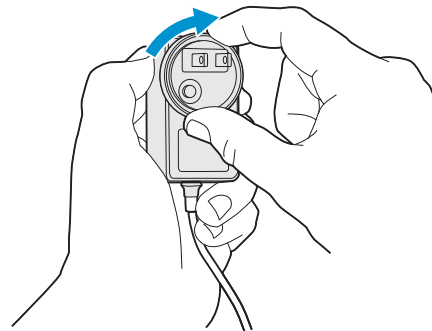
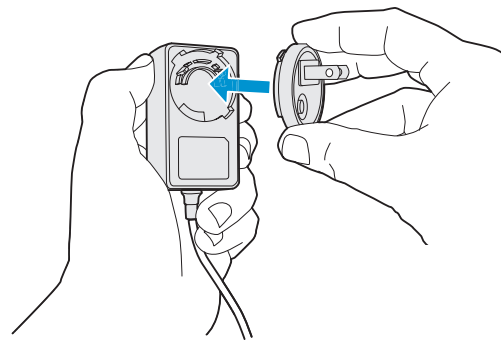



## Charge the Battery

Mise en charge de la batterie • Akku laden • Cargar la batería • Caricare la batteria • Accu opladen • Ladda batteriet • 给電池充电 • 給電池充電 • 電池の充電

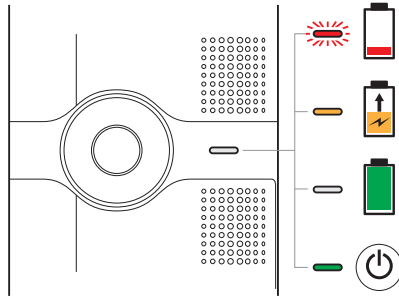
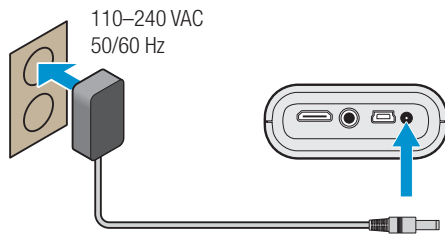

## Turn the Projector On and Off

Mise en marche et arrêt du projecteur • Stellen Sie den Projektor an und ab • Dé vuelta al proyector por intervalos • Giri il proiettore in funzione e a riposo • Draai de aan en uit Projector • Vänd projektorn på och stänga av • 打开和关上放映机 • 打開和關上放映機 • プロジェクターを不規則に回しなさい

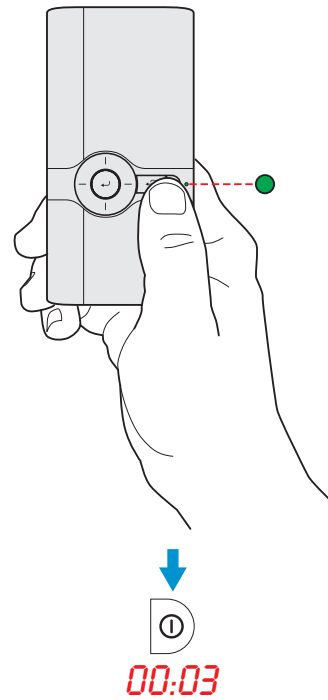



3M™ Pocket Projector MPro150

## Projection Mode

Mode de projection • Projektionsmodus • Modo proyección •  
 Modalità proiezione • Projectiemodus • Visningsläge •  
 投影模式 • 投影模式 • 投影モード

### Connect a Video Source

Connexion d'une source vidéo • Eine Videoquelle anschließen • Conecte una fuente de video • Collegare a una sorgente video • Een videobron aansluiten • Anslut en video • 连接视频源 • 连接视讯源 • ビデオソースの接続

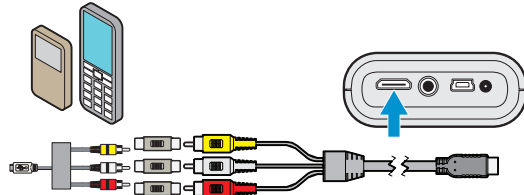
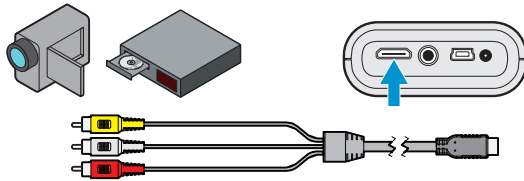

Note: Some devices require a special cable to connect to the projector.

Remarque: Certains dispositifs nécessitent un câble spécial pour effectuer le branchement au projecteur.

Hinweis: Einige Geräte erfordern ein besonderes Kabel für den Anschluss an den Projektor.

Note: Algunos dispositivos requieren un especialCable para conectar el proyector.

Nota: Alcuni dispositivi richiedono un cavo speciale per il collegamento al proiettore.

Opmerking: Sommige apparaten hebben een speciale kabel nodig om te kunnen worden aangesloten op de projector.

OBS: Vissa enheter kräver speciella kablar för anslutning till projektorn.

注意：一些设备需要一条特殊的电缆，以连接到投影机。

注意：一些設備需要一條特別的電纜，以連接到該投影機。

メモ：デバイスの中には、プロジェクターに接続する特別なケーブルを必要とするものがあります。

### Connect a Computer

Connexion d'un ordinateur • Einen Computer anschließen • Conectar un ordenador • Collegare un computer • Aansluiten op een computer • Anslut en dator • 连接电脑 • 连接電腦 • コンピュータの接続

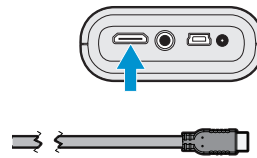

Description	Resolution	Refresh Rate
VGA	640 x 480	60 Hz
SVGA	800 x 600	60 Hz
XGA	1024 x 768	60 Hz
WXGA	1280 x 768	60 Hz





## Projection Mode

Mode de projection • Projektionsmodus • Modo proyección •  
Modalità proiezione • Projectiemodus • Visningsläge •  
投影模式 • 投影模式 • 投影モード

## Adjust the Volume

Réglage du volume • Einstellen der Lautstärke •  
Ajustar el volumen • Regolare il volume •  
Het volume aanpassen • Justera volymen •  
调节音量 • 調整音量 • 音量の調整

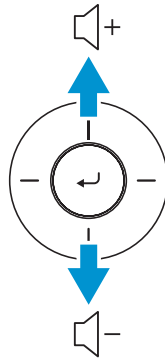

## Check the Battery Level

Vérification du niveau de la batterie • Prüfen des  
Akku-Ladezustands • Comprobar el nivel de batería  
• Controllare il livello della batteria • Het accuniveau  
controleren • Kontrollera batterinivån •  
检查电池水平 • 檢查電池水平 •  
電池レベルのチェック

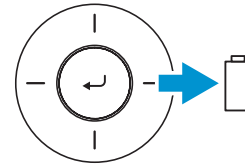

## Change the Brightness

Modification de la luminosité • Ändern der Helligkeit  
• Cambiar el brillo • Modificare la luminosità •  
De helderheid wijzigen • Ändra ljusstyrka •  
改变亮度 • 改變亮度 • 輝度の変更

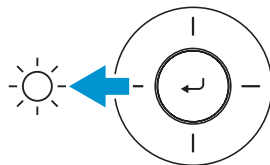

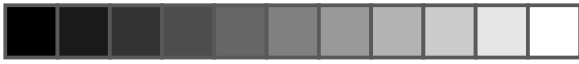

3M™ Pocket Projector MPro150

## Media Player Mode

Mode lecture de média • Media Player-Modus • Modo de reproducción de medios •  
Modalità riproduttore multimediale • Media playermodus • Mediaspelning •  
媒体播放机模式 • 媒體播放器模式 • メディアプレーヤーのモード

## Install Optional Micro SD Card

Installation d'une carte micro SD en option •  
Einlegen der optionalen Mikro SC-Karte • Instalar  
la tarjeta Micro SD opcional • Installare la scheda  
opzionale Micro SD • De optionele Micro SD-kaart  
installeren • Installera (valfritt) Micro SD-kort •  
安装供选的Micro SD卡 • 安裝可選的Micro  
SD卡 • オプションのマイクロ SD カードの  
取り付け

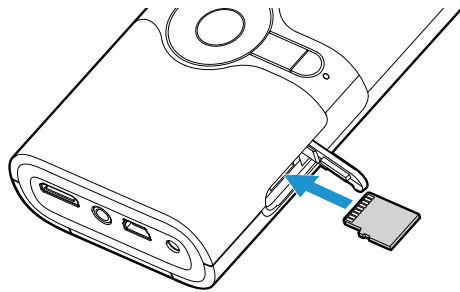

To insert or remove the Micro SD card, press it in until it clicks.  
Pour introduire et retirer la carte micro SD, appuyer sur celle-ci  
jusqu'à percevoir un déclic.  
Zum Einschieben oder Entfernen der Mikro SD-Karte drücken Sie  
diese ein, bis ein Klicken hörbar ist.  
Para insertar o quitar la tarjeta Micro SD, presiónela hasta que  
haga clic.  
Per inserire o rimuovere la scheda Micro SD, spingerla fino ad  
avvertire uno scatto.  
Druk op de Micro SD-kaart tot deze klikt om de kaart te plaatsen  
of te verwijderen.  
För att stoppa i eller ta ut Micro SD-kortet, tryck det inåt tills ett  
klick hörs.  
要插入或取出Micro SD卡, 将其按入至听到咔嚓声为  
止。  
要插入或者取出Micro SD卡, 将其按入, 直至聽到啵啵  
聲為止。  
マイクロ SD カードを取り付けまたは取り外しするには、  
カチッと音がするまで押し込みます。

© 2009 3M. All Rights Reserved.

## Transfer Files

Transfert de fichiers • Übertragung von Dateien  
• Transferir archivos • Trasferire file • Bestanden  
overzetten • Överföringsfiler • 传送文件 •  
傳送文件 • ファイルの転送

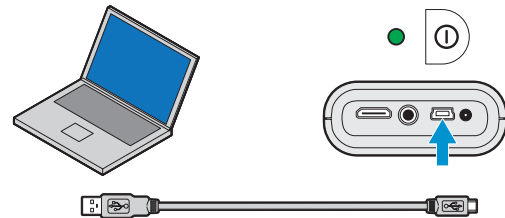

7





## Replacement Parts & Accessories

Description	3M Part Number
Power Adapter with US, EU, UK, AUS plugs	78-6972-0003-4
Lithium-Ion Polymer Battery	78-6972-0004-2
AV Video Cable	78-6972-0006-7
VGA Cable	78-6972-0007-5
Car Charger	78-6972-0002-6
Component AV cable	78-6972-0005-9
3M Adapter Cable for Apple®	78-6972-0001-8
Portable Presentation Binder	78-6969-9997-4

3M is a trademark of 3M Company.



### Projection Systems 3M Austin Center

6801 River Place Blvd.  
Austin, TX 78726-9000  
866-631-1656  
[www.3M.com/meetings](http://www.3M.com/meetings)  
[meetings@mmm.com](mailto:meetings@mmm.com)

Please Recycle. Printed in USA.  
© 3M 2009. All Rights Reserved.  
78-6971-1517-4

