

2008/05/02 02:28:32 CAROL TRIBBLE

DRAWING FOR REFERENCE: This is subject to change without notice

COUNT	DESCRIPTION OF REVISIONS	BY	CHKD	DATE	COUNT	DESCRIPTION OF REVISIONS	BY	CHKD	DATE
△					△				
△					△				
APPLICABLE STANDARD		EIAJ RC-5240							
RATING	OPERATING TEMPERATURE RANGE	-40 °C TO +85 °C			STORAGE TEMPERATURE RANGE	-40 °C TO +85 °C			
	VOLTAGE	AC 50V			OPERATING HUMIDITY RANGE	5 % TO 85 %			
	CURRENT	0.3 A			APPLICABLE CABLE	-			
SPECIFICATIONS									
ITEM		TEST METHOD			REQUIREMENTS			QT	AT
CONSTRUCTION									
GENERAL EXAMINATION		VISUALLY AND BY MEASURING INSTRUMENT.			ACCORDING TO DRAWING.			○	○
MARKING		CONFIRMED VISUALLY.						○	○
ELECTRIC CHARACTERISTICS									
CONTACT RESISTANCE		100 mA (DC OR 1000 Hz).			50 mΩ MAX.			○	-
INSULATION RESISTANCE		250 V DC.			100 MΩ MIN.			○	-
VOLTAGE PROOF		250 V AC FOR 1 min.			NO FLASHOVER OR BREAKDOWN.			○	○
MECHANICAL CHARACTERISTICS									
INSERTION AND WITHDRAWAL FORCES		MEASURED BY APPLICABLE CONNECTOR.			INSERTION FORCE 24.5 N MAX. WITHDRAWAL FORCE 2.5 N MIN.			○	-
MECHANICAL OPERATION		10000 TIMES INSERTIONS AND EXTRACTIONS.			① CONTACT RESISTANCE : 100 mΩ MAX. ② INSERTION FORCE 24.5 N MAX. WITHDRAWAL FORCE 1.9 N MIN. ③ NO DAMAGE, CRACK AND LOOSENESS, OF PARTS.			○	-
VIBRATION		FREQUENCY 10 TO 55 Hz, SINGLE AMPLITUDE 0.75 mm, AT 2 h, FOR 3 DIRECTIONS, TOTAL 6 h.			① NO ELECTRICAL DISCONTINUITY OF 1 μs. ② NO DAMAGE, CRACK AND LOOSENESS, OF PARTS.			○	-
SHOCK		490 m/s ² DIRECTIONS OF PULSE 11 ms AT 3 TIMES FOR 6 DIRECTIONS, TOTAL 18 TIMES.						○	-
ENVIRONMENTAL CHARACTERISTICS									
RAPID CHANGE OF TEMPERATURE		TEMPERATURE -40 → 25 → 85 → 25 °C TIME 30 → 2 TO 3 → 30 → 2 TO 3 min UNDER 5 CYCLES.			① CONTACT RESISTANCE : 100 mΩ MAX. ② NO DAMAGE, CRACK AND LOOSENESS, OF PARTS.			○	-
DAMP HEAT (STEADY STATE)		EXPOSED AT 40±2 °C, 90~95 %, 96 h (FOR 4 DAYS).			① CONTACT RESISTANCE : 100 mΩ MAX. ② INSULATION RESISTANCE : 10 MΩ MIN. ③ NO FLASHOVER OR BREAKDOWN. ④ NO DAMAGE, CRACK AND LOOSENESS, OF PARTS.			○	-
DRY HEAT		EXPOSED AT +85±2 °C, 96±4 h.			① CONTACT RESISTANCE : 100 mΩ MAX. ② NO DAMAGE, CRACK AND LOOSENESS, OF PARTS.			○	-
COLD		EXPOSED AT -40±3 °C, 96±4 h.			① CONTACT RESISTANCE : 100 mΩ MAX. ② NO DAMAGE, CRACK AND LOOSENESS, OF PARTS.			○	-
CORROSION SALT MIST		EXPOSED IN 5±1 % SALT WATER, 35±3 °C FOR 48 ±4 h.			① CONTACT RESISTANCE : 100 mΩ MAX. ② NO HEAVY CORROSION.			○	-
REMARKS					DRAWN	DESIGNED	CHECKED	APPROVED	RELEASED
Unless otherwise specified, refer to JIS C 5402.					<i>M. Shingama</i> 05.2.15	<i>M. Shingama</i> 05.2.15	<i>[Signature]</i> 05.2.15	<i>[Signature]</i> 05.2.15	
Note QT:Qualification Test AT:Assurance Test ○:Applicable Test									
HS HIROSE ELECTRIC CO., LTD.					SPECIFICATION SHEET			PART NO. MQ212-10PT	
CODE NO.(OLD) CL		DRAWING NO. ELC4-124468			CODE NO. CL206-2428-3			1/2	

TO
Q



2008/05/02 02:28:32 CAROL TRIBBLE

DRAWING FOR REFERENCE: This is subject to change without notice

TO
Q

SPECIFICATIONS						
ITEM	TEST METHOD	REQUIREMENTS	QT	AT		
SOLDERABILITY	SOLERRING POINT OF CONTACTS IMMERSION IN SOLDER BATH OF 235±5°C, 2±0.5 sec.	SOLDERING POINT OF CONTACTS IMMERSION IN SOLDER, 90% MIN.	○	-		
RESISTANCE TO SOLDERING HEAT	MOLTEN-SDDER TEMPERATURE: 260±5°C. IMMERSION DURABILITY PER LOCATION: 2± 1 sec.	NO DAMAGE, CRACK AND LOOSENESS, OF PARTS.	○	-		
REMARKS		DRAWN	DESIGNED	CHECKED	APPROVED	RELEASED
Unless otherwise specified, refer to JIS C 5402.		<i>M. Shimoyama</i> DS. 2. 15	<i>M. Shimoyama</i> DS. 2. 15	<i>[Signature]</i> DS. 2. 15	<i>[Signature]</i> DS. 2. 15	
		Note QT:Qualification Test AT:Assurance Test ○:Applicable Test				
HRS HIROSE ELECTRIC CO., LTD.		SPECIFICATION SHEET		PART NO.		
CODE NO.(OLD) CL		DRAWING NO. ELC4-124468		CODE NO. CL206-2428-3		2/2
				MQ212-10PT		

FORM No.231-2



2008/05/02 02:28:32 CAROL TRIBLE

DRAWING FOR REFERENCE: This is subject to change without notice

TO
Q
F

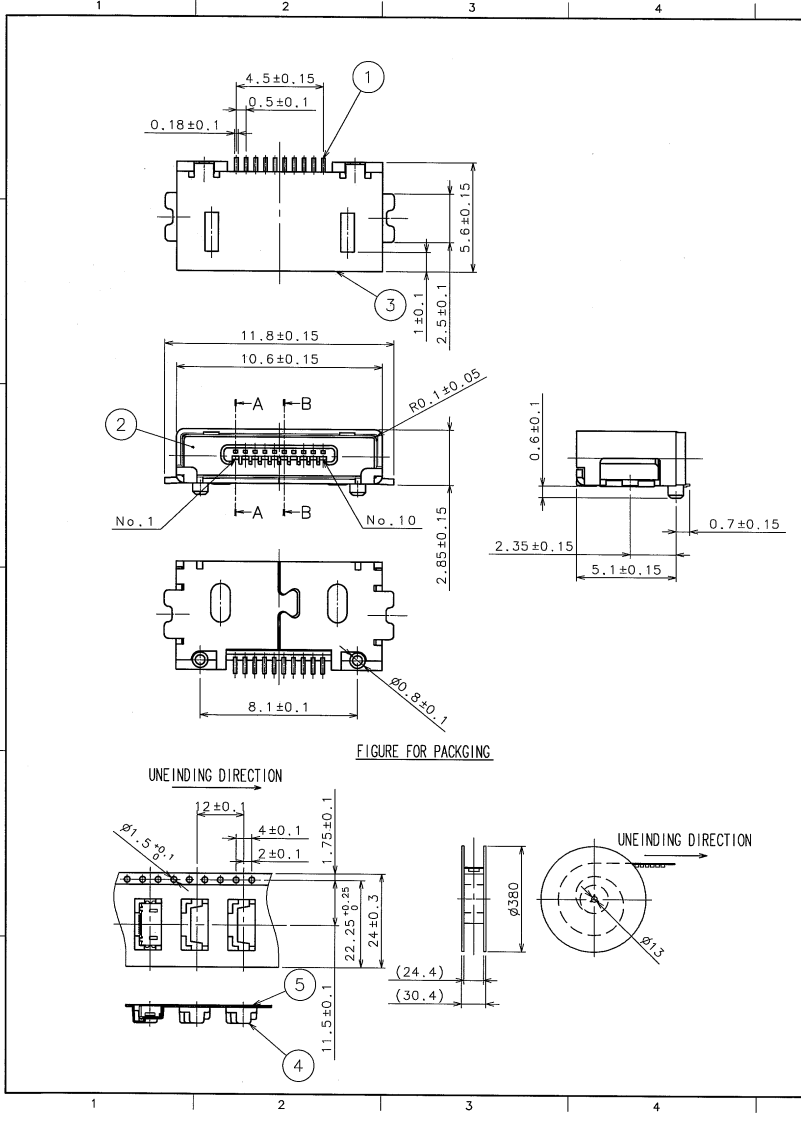

COUNT	DESCRIPTION OF REVISIONS	BY	CHKD	DATE	COUNT	DESCRIPTION OF REVISIONS	BY	CHKD	DATE

RECOMMENDED PC BOARD PATTERN

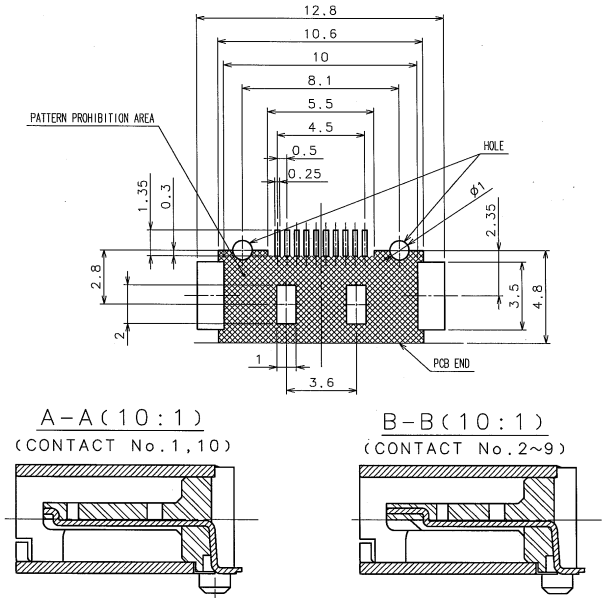

A-A (10:1)
(CONTACT No. 1, 10)

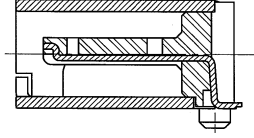

B-B (10:1)
(CONTACT No. 2~9)

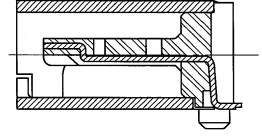

NOTE 1 PER REL: 1500 PIECES.
2 CO-PLANARITY TO BE 0.1mm MAX.

NO.	MATERIAL	FINISH, REMARKS	NO.	MATERIAL	FINISH, REMARKS
2	LCP	UL94V-0 (BLACK)	5	PS	
1	PHOSPHOR BRONZE	UNDER PLATING: NICKEL 2μm MIN CONTACT AREA: GOLD 0.25μm MIN LEAD AREA: GOLD FLASH	3	PHOSPHOR BRONZE	UNDER PLATING: NICKEL 1μm MIN MOUNTING AREA: TIN 1μm MIN
CODE NO. (OLD)			DRAWN DESIGNED CHECKED APPROVED RELEASED <i>M. Shingara M. Shingara</i>		
DRAWING NO. EDC3-124468			PART NO. MQ212-10PT		
SCALE 5:1 UNITS mm			CODE NO. CL206-2428-3		