

**NOTES:**

1. ASSEMBLY NO. 71690-23\*\* SHOWN FOR ILLUSTRATION.
2. MATES WITH PART NUMBER 71694-\*\*\*\*.
3. SEE SHEET 2 FOR PART NUMBERS AND THEIR CONFIGURATIONS.
4. FINISHES (SEE CHART):  
 TIN OVERALL - .000100/(0.00254) MINIMUM TIN OVERALL, OVER NICKEL UNDERPLATING OVERALL.  
 15 GOLD - .000015/(0.00038) MINIMUM SELECT GOLD AND .000150/(0.00380) MINIMUM SELECT TIN OVER NICKEL UNDERPLATING OVERALL.
5. ITEM NUMBERS PRECEDED BY AN \*X\* IN THE CHART ARE NOT AVAILABLE.
6. RECOMMENDED FOR USE WITH UL # 1007 STYLE WIRE.
7. OPTIONAL COVER NUMBERS: 71611-\*\*01 (FEED THRU) OR -\*\*02 (FEED TO VERSION).
8. SEE SHEET 7 FOR PANEL CUTOUT DETAIL.
9. PART CONFORMS TO SPECIFICATION NO. PS-71690-001.
10. RECYCLE LOGO: >PBT< FR TO BE LOCATED IN THIS AREA.
11. IDT SLOT IDENTIFIER COLOR STRIPE TO BE LOCATED ON THIS SURFACE. ID PER CHART BELOW.

WIRE GAUGE	ID COLOR
18	FLRSCNT MAGENTA
20	BLUE
22	GREEN
24	BLACK

12. SEE SMES-71690-0000 FOR TERMINATION SPECIFICATIONS.
13. PACKAGE PER PK-71690-0000.

NOTE FOR LEAD FREE CONVERSION:  
 THE PRIMARY SHIPPING CARTON WILL BE LABELED "COMPLIANT TO ROHS DIRECTIVE 2002/95/EC AND ELV ANNEX II OF DIRECTIVE 2000/53/EC". CARTONS WITHOUT THIS LABEL MAY CONTAIN PRODUCT WITH LEAD.

REV.	DATE	DESCRIPTION
L	04/04/20	LEAD FREE CONV ECR UD2004-2042 ADAMS
K	01/01/95	CHANGE PROD SPEC PER ECR UD2001-0195 KMS 9/22/2000
J	07/22/96	ALL WHITE MAT'L PER EC # U71026 ELO 97/2/26
I	10/23/96	18 AWG CLR CHANGE PER ECR U70413 ELO 10/23/96
H	03/15/95	REVISED PER ECR U61437 03/15/95 PAIR
G	03/27/96	REVISED PER ECR U61185 03/27/96 TSE
F	08/30/95	ADD GOLD ASSY'S PER ECR U51189 08/30/95 SCS
E	07/26/95	REV CHARTS/D DIM PER ECR U60094 07/26/95 SCS
D	04/17/95	ADD HOLE/NOTE I2 PER ECR U50939 04/17/95 SCS
C	08/10/94	ADD DIM/REV NOTE PER ECR U40014 8/10/94 SCS
B		ADD NOTE I1 PER ECR U40717 6/29/94 SCS
A		FINAL RELEASE PER ECR U40514 4/25/94 SCS

DIMENSIONS SHOWN (METRIC) INCH		REVISE ONLY ON CAD SYSTEM	
TOLERANCES UNLESS SPECIFIED		TITLE	
TOLERANCES ANGULAR ± 0.2°		MINI-FIT IDT SINGLE ROW PLUG SALES ASSEMBLY	
INCH METRIC		DATE	
3 PLACE ± .010	---	01/28/93	
2 PLACE ± .014 ± 0.25	---	SHEET NO. 1 OF 8	
1 PLACE --- ± 0.36	---	MOLEX INCORPORATED U.S.A.	
DRAFT WHERE APPLICABLE MUST REMAIN WITHIN DIMENSIONS		PART NO. SDA-71690-0000	
DRG. NO. 69532		DRG. NO. SDA-71690-0000	
DRG. BY RWB		DRG. BY SAS	
SCALE 4:1		FILE NAME 571690X1.DWG	
APP'D. BY		NO DRAWING CONTAINS INFORMATION THAT IS PROPRIETARY TO MOLEX INC. AND SHOULD NOT BE USED WITHOUT WRITTEN PERMISSION.	

CKT SIZE	STAT	ASSEMBLY ITEM NUMBER	PANEL MOUNTS	WIRE AWG	WIRE DESCRIPTION	DIMENSION A		DIMENSION B		DIMENSION C		PLATING SEE NOTE 4
						INCH	(MM)	INCH	(MM)	INCH	(MM)	
2		71690-1001	NO	18	SOLID, FUSED STRANDED, STRANDED	0.490	(12.45)	0.378	(9.60)	0.1654	(4.20)	TIN OVERALL
2		71690-1003	NO	20		0.490	(12.45)	0.378	(9.60)	0.1654	(4.20)	TIN OVERALL
2		71690-1004	NO	22		0.490	(12.45)	0.378	(9.60)	0.1654	(4.20)	TIN OVERALL
2		71690-1005	NO	24		0.490	(12.45)	0.378	(9.60)	0.1654	(4.20)	TIN OVERALL
2		71690-1007	NO	18		0.490	(12.45)	0.378	(9.60)	0.1654	(4.20)	15 GOLD
2		71690-1009	NO	20		0.490	(12.45)	0.378	(9.60)	0.1654	(4.20)	15 GOLD
2		71690-1010	NO	22		0.490	(12.45)	0.378	(9.60)	0.1654	(4.20)	15 GOLD
2		71690-1011	NO	24		0.490	(12.45)	0.378	(9.60)	0.1654	(4.20)	15 GOLD
2		71690-1101	YES	18		0.821	(20.48)	0.378	(9.60)	0.1654	(4.20)	TIN OVERALL
2		71690-1103	YES	20		0.821	(20.48)	0.378	(9.60)	0.1654	(4.20)	TIN OVERALL
2		71690-1104	YES	22		0.821	(20.48)	0.378	(9.60)	0.1654	(4.20)	TIN OVERALL
2		71690-1105	YES	24		0.821	(20.48)	0.378	(9.60)	0.1654	(4.20)	TIN OVERALL
2		71690-1107	YES	18		0.821	(20.48)	0.378	(9.60)	0.1654	(4.20)	15 GOLD
2		71690-1109	YES	20		0.821	(20.48)	0.378	(9.60)	0.1654	(4.20)	15 GOLD
2		71690-1110	YES	22		0.821	(20.48)	0.378	(9.60)	0.1654	(4.20)	15 GOLD
2		71690-1111	YES	24		0.821	(20.48)	0.378	(9.60)	0.1654	(4.20)	15 GOLD
3		71690-1401	NO	18		0.655	(16.65)	0.543	(13.80)	0.3307	(8.40)	TIN OVERALL
3		71690-1403	NO	20		0.655	(16.65)	0.543	(13.80)	0.3307	(8.40)	TIN OVERALL
3		71690-1404	NO	22		0.655	(16.65)	0.543	(13.80)	0.3307	(8.40)	TIN OVERALL
3		71690-1405	NO	24		0.655	(16.65)	0.543	(13.80)	0.3307	(8.40)	TIN OVERALL
3		71690-1407	NO	18		0.655	(16.65)	0.543	(13.80)	0.3307	(8.40)	15 GOLD
3		71690-1409	NO	20		0.655	(16.65)	0.543	(13.80)	0.3307	(8.40)	15 GOLD
3		71690-1410	NO	22		0.655	(16.65)	0.543	(13.80)	0.3307	(8.40)	15 GOLD
3		71690-1411	NO	24		0.655	(16.65)	0.543	(13.80)	0.3307	(8.40)	15 GOLD
3		71690-1501	YES	18		0.986	(25.05)	0.543	(13.80)	0.3307	(8.40)	TIN OVERALL
3		71690-1503	YES	20		0.986	(25.05)	0.543	(13.80)	0.3307	(8.40)	TIN OVERALL
3		71690-1504	YES	22		0.986	(25.05)	0.543	(13.80)	0.3307	(8.40)	TIN OVERALL
3		71690-1505	YES	24		0.986	(25.05)	0.543	(13.80)	0.3307	(8.40)	TIN OVERALL
3		71690-1507	YES	18		0.986	(25.05)	0.543	(13.80)	0.3307	(8.40)	15 GOLD
3		71690-1509	YES	20		0.986	(25.05)	0.543	(13.80)	0.3307	(8.40)	15 GOLD
3		71690-1510	YES	22		0.986	(25.05)	0.543	(13.80)	0.3307	(8.40)	15 GOLD
3		71690-1511	YES	24	SOLID, FUSED STRANDED, STRANDED	0.986	(25.05)	0.543	(13.80)	0.3307	(8.40)	15 GOLD

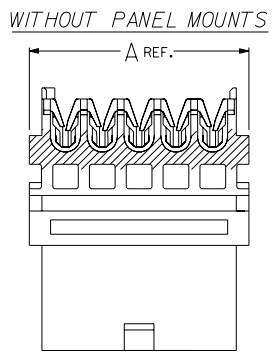

L	SEE SHEET I
H	SEE SHEET I
F	SEE SHEET I
D	SEE SHEET I
C	SEE SHEET I
A	SEE SHEET I
4	SEE SHEET I
3	SEE SHEET I
2	SEE SHEET I
1	SEE SHEET I

**POLARIZATION SCHEME**

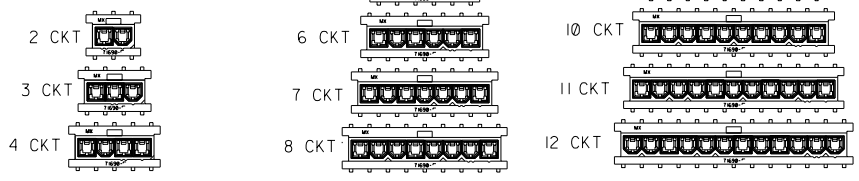

DIMENSIONS SHOWN IN METRIC INCH		REVISIONS	
UNLESS OTHERWISE SPECIFIED TOLERANCES ANGULAR ± 1/2°		MFG. SH.	REV. LTR.
DRAFT WHERE APPLICABLE MUST REMAIN WITHIN DIMENSIONS		REVISE ONLY ON CAD SYSTEM	
± PLACE ± .010	---	TITLE	
± PLACE ± .014	± 0.25	MINI-FIT IDT SINGLE ROW PLUG ASSEMBLY	
± PLACE ---	± 0.36	PART NO. DATE	
MOLEX INCORPORATED U.S.A.		1515 E. 17TH AVE. DATE 01/28/93	
SEE CHART		SDA-71690-****	
DRWG. BY RWB	CHK'D. BY SAS	FILE NAME	NO DRAWING CONTAINS INFORMATION THAT IS PROPRIETARY TO MOLEX INC. AND SHOULD NOT BE USED WITHOUT WRITTEN PERMISSION.
APP'D. BY	SCALE	DRG. NO.	SIZE TC



**MOLEX INCORPORATED**  
LISLE, ILL. 60532 U.S.A.

## WIRE TERMINATION SPECIFICATION

- 1.0 APPLICABLE DRAWINGS:  
THIS SPECIFICATION APPLIES TO A-71690 AND A-71694 SERIES OF INSULATION DISPLACEMENT CONNECTORS.
- 2.0 SCOPE:  
THIS SPECIFICATION IS DESIGNED TO INSURE THE PROPER TERMINATION AND PERFORMANCE OF THE A-71690 AND A-71694 SERIES OF INSULATION DISPLACEMENT CONNECTORS.
- 3.0 GENERAL:  
THE .1654/(4.20) CENTER INSULATION DISPLACEMENT CONNECTOR SYSTEM IS DESIGNED TO INTERCONNECT DISCRETE WIRE AS OUTLINED IN THIS SPECIFICATION.

### 4.0 CONDUCTOR REQUIREMENTS:

#### 4.1 CONDUCTOR SIZE IDENTIFICATION:

CONDUCTOR SIZE	CONDUCTOR STYLE	HOUSING ID COLOR (SEE FIG. 4)	TERMINAL ID HOLE POSITION (SEE FIG.8; SHT.5)
18 AWG	STRANDED WITH TOPCOAT,FUSED, SOLID	RED	POSITION 1
20 AWG	STRANDED WITH TOPCOAT,FUSED, SOLID	BLUE	POSITION 2
22 AWG	STRANDED WITH TOPCOAT,FUSED, SOLID	GREEN	POSITION 3
24 AWG	STRANDED WITH TOPCOAT,FUSED, SOLID	BLACK	POSITION 4

RECOMMENDED UL STYLE: 1007, 1061

#### 4.2 INSULATION REQUIREMENTS:

INSULATION DIAMETER: .090 MAX  
INSULATION HARDNESS: 85 MAX ON THE SHORE A SCALE

### 5.0 TERMINATION REQUIREMENTS:

#### 5.1 CABLE INSERTION DEPTH:

THE CABLE SHOULD BE INSERTED TO DEPTH OF .140/(3.56)\* FROM THE TOP OF THE HOUSING TO THE TOP OF THE WIRE (SEE FIGURE 2). WIRE MUST BE LOCATED BELOW THE BOTTOM OF EAGLES.

\* TERMINATION DEPTH FOR THE 24 AWG WIRES IN THE FOLLOWING ASSEMBLIES TO BE .138±.005/(3.51±0.13); 71690-6008 AND 71694-2402.

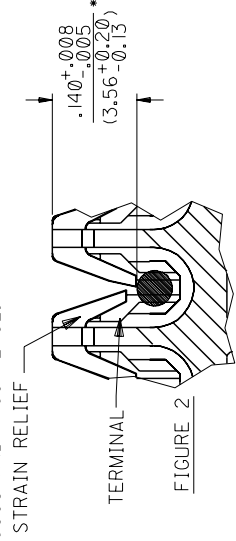

REV.	B	A	B	B	B
SHT.	1	2	3	4	5

FILE NAME: T71690X1  
 = 0  
 = 0

REVISE ONLY ON CAD SYSTEM

REV. B

SHT. 1 OF 5

DRWG. NO. SMES-71690-0000

DRWG. NO. SMES-71690-0000

THIS DRAWING CONTAINS INFORMATION THAT IS PROPRIETARY TO MOLEX INC. AND SHOULD NOT BE USED WITHOUT WRITTEN PERMISSION.



## WIRE TERMINATION SPECIFICATION

### 5.2 WIRE CUT OFF

IN THE FEED-TO VERSION THE WIRE MUST BE DISPLACED IN BOTH INSULATION DISPLACEMENT SLOTS AND MUST PROTRUDE THROUGH THE SECONDARY SLOT BY (1.52)/.060 MIN. AS SHOWN IN FIGURE 3.

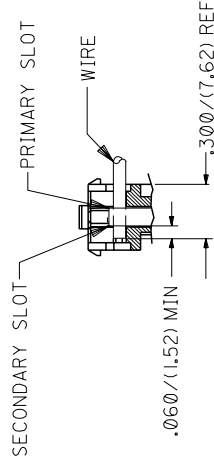

FIGURE 3

### 5.3 HORIZONTAL PULL OUT FORCE

THE CONNECTOR MUST MAINTAIN THE FOLLOWING MIN. PULL OUT VALUES WHEN A FORCE IS APPLIED AT A RATE OF 1 INCH PER MINUTE TO THE CABLE IN A DIRECTION PERPENDICULAR TO THE INSULATION DISPLACEMENT SECTION, AS SHOWN IN FIGURE 4. (NOTE CABLE MUST BE SLIT TO FORM INDIVIDUAL CONDUCTORS AFTER TERMINATION BUT PRIOR TO TESTING).

AWG	PULL FORCE
18 AWG	14.0 LBS. MIN.
20 AWG	TBD
22 AWG	TBD
24 AWG	8.0 LBS. MIN.

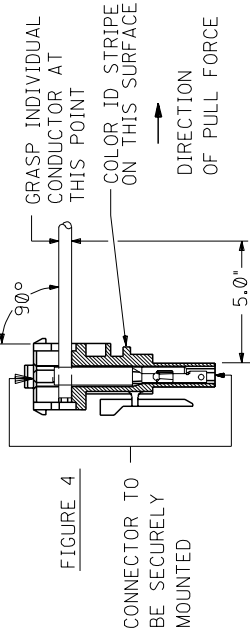

FIGURE 4

### 5.4 VERTICAL PULL OUT FORCE

THE CONNECTOR MUST MAINTAIN THE FOLLOWING MIN. PULL OUT VALUES WHEN A FORCE IS APPLIED AT A RATE OF 1 INCH PER MINUTE TO THE CABLE IN A DIRECTION PARALLEL TO THE INSULATION DISPLACEMENT SECTION, AS SHOWN IN FIGURE 5. (NOTE CABLE MUST BE SLIT TO FORM INDIVIDUAL CONDUCTORS AFTER TERMINATION BUT PRIOR TO TESTING).

AWG	PULL FORCE
18 AWG	5.0 LBS. MIN.
20 AWG	TBD
22 AWG	TBD
24 AWG	2.4 LBS. MIN.

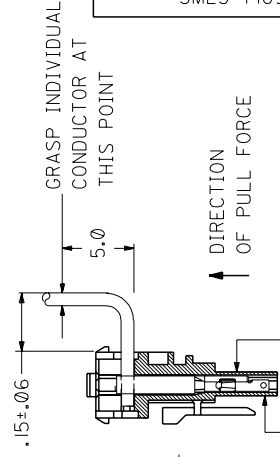

FIGURE 5

REV.

SHT.

FILE NAME  
T71690X2

REVISIONS:  $\nabla = 0$  REVISE ONLY ON CAD SYSTEM

REV. A

SHT. 2



MOLEX INCORPORATED  
LISLE, ILL. 60532 U.S.A.

## WIRE TERMINATION SPECIFICATION

**5.5 TORSIONAL RESISTANCE:**  
CONNECTOR MUST WITHSTAND A MAXIMUM TWIST OF 130° WITHOUT DISTURBING THE INSULATION DISPLACEMENT INTERFACE IN THE PRIMARY OR SECONDARY SLOTS (SEE FIGURE 3) (NOTE CABLE MUST BE SLIT TO FORM INDIVIDUAL CONDUCTORS AFTER TERMINATION BUT PRIOR TO TESTING).

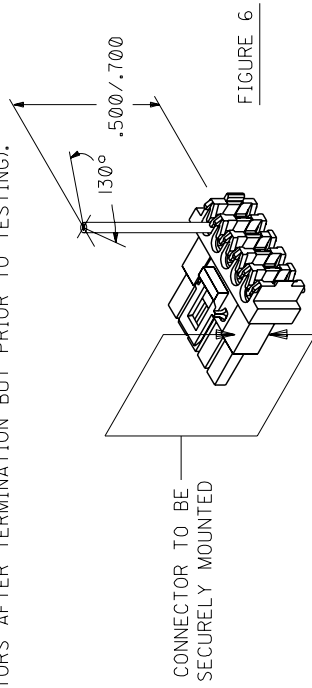

**5.6 VISUAL INSPECTION:**  
AFTER TERMINATION, INSULATION DISPLACEMENT SECTION OF THE TERMINAL TO BE FREE OF TOOL MARKS FROM TERMINATION EQUIPMENT.

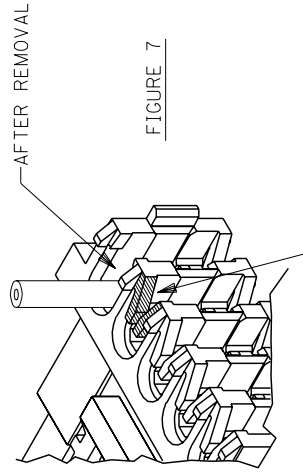

**6.0 TERMINATION EVALUATION PROCEDURE:**

**STEP 1 - STRAIN RELIEF REMOVAL**  
REMOVE SHADED PORTION OF THE STRAIN RELIEF USING A RAZOR BLADE

**STEP 2 - REMOVAL OF TERMINAL**  
INSERT THE REMOVAL TOOL (#HT60630A) INTO THE FRONT OF OF THE CONNECTOR (AROUND THE TERMINAL) TO DEPRESS LOCK TANGS. PUSH THE TERMINAL/WIRE OUT THE BACK OF THE CONNECTOR.

REV.

SHT.

FILE NAME  
T71690X3

REVISION SYMBOLS  
= 0 = 0

REVISE ONLY ON CAD SYSTEM

REV. B  
SHT. 3

DRWG. NO. SMES-71690-0000

DRWG. NO. SMES-71690-0000

THIS DRAWING CONTAINS INFORMATION THAT IS PROPRIETARY TO MOLEX INC. AND SHOULD NOT BE USED WITHOUT WRITTEN PERMISSION.



MOLEX INCORPORATED  
LISLE, ILL. 60532  
U.S.A.

## WIRE TERMINATION SPECIFICATION

STEP 3 -CONDUCTOR REMOVAL  
USING A SMALL PAIR OF PLIERS SPREAD THE I.D.T. SLOT  
AND REMOVE CONDUCTOR BY PUSHING IN DIRECTION SHOWN

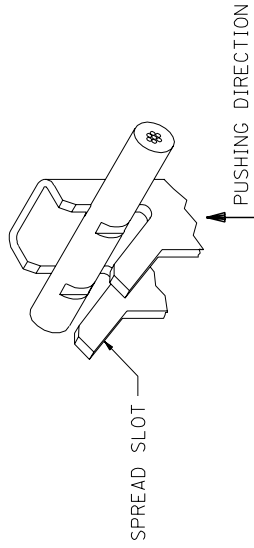

STEP 4 -REMOVING INSULATION  
INSULATION TO BE REMOVED WITHOUT DISTURBING I.D.T. AREA

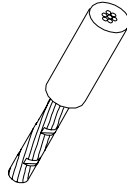

STEP 5 -CONDUCTOR INSPECTION  
FOUR DEFORMATION POINTS MUST BE CLEARLY VISIBLE WHEN  
USING 10X MAGNIFICATION

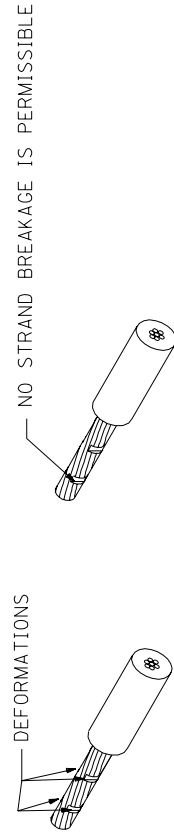

DRWG. NO. SMES-71690-0000

REV.  
SHT.

FILE NAME  
T71690X4

▽ = 0    ▲ = 0

REVISE ONLY ON CAD SYSTEM

REV. B

SHT. 4

THIS DRAWING CONTAINS INFORMATION THAT IS PROPRIETARY TO MOLEX INC. AND SHOULD NOT BE USED WITHOUT WRITTEN PERMISSION.

DRWG. NO. SMES-71690-0000



**MOLEX INCORPORATED**  
 LISLE, ILL. 60532  
 U.S.A.

## WIRE TERMINATION SPECIFICATION

LTR.	REVISIONS
A	RELEASED PER ECR U51189 09/15/95 sas
B	UPDATED PER ECR U70308 ELO 09/20/96

### STEP 1 -REMOVAL OF TERMINAL

INSERT THE REMOVAL TOOL(#HT60630A) INTO THE FRONT OF OF THE CONNECTOR (AROUND THE TERMINAL) TO DEPRESS LOCK TANGS.  
 PUSH THE TERMINAL/WIRE OUT THE BACK OF THE CONNECTOR.

### STEP 2 -WIRE GAGE PER CHART

ID LETTER	WIRE GAGE
D	18 AWG
C	20 AWG
B	22 AWG
A	24 AWG

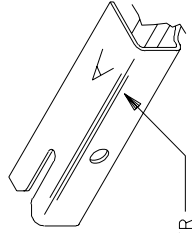

ID LETTER

FIGURE 8

DRWG. NO. SMES-7 1690-0000

REV.  
SHT.  
T71690X5

FILE NAME  
T71690X5

REVISIONS  
 0 = 0  
 1 = 0

REVISE ONLY ON CAD SYSTEM

REV. B  
SHT. 5

THIS DRAWING CONTAINS INFORMATION THAT IS PROPRIETARY TO MOLEX INC. AND SHOULD NOT BE USED WITHOUT WRITTEN PERMISSION.

DRWG. NO. SMES-7 1690-0000