

SECTION A-A

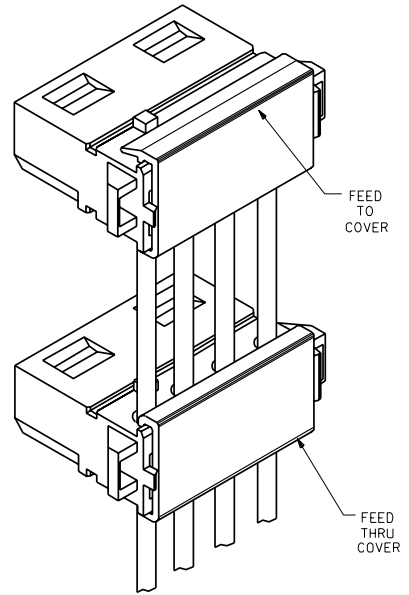

.0805±.0010
(2.045±0.025)
DIA.
(TERMINAL BARREL)

NOTES:

1. ALL WIRES TO HAVE A MAX. DIAMETER OVER INSULATION OF .095/(2.41).
2. COVERS ARE SUGGESTED TO RETAIN WIRES. FEED TO DRAWING NO. SD-70156-4000. FEED THRU DRAWING NO. SD-70156-3000. SEE SHEET 2 FOR AVAILABLE KITS.
3. MATERIAL: HOUSING-NYLON, TYPE 6/6, 94V-2, COLOR: NATURAL
HOUSING-POLYESTER, 94V-0
COLOR: WHITE
TERMINAL-PHOSPHOR BRONZE
4. .008/(0.20) MAX. VERTICAL PROJECTION DUE TO CARRIER CUT-OFF.
5. PS-70156-***** APPLIES.
6. SDES-70156 APPLIES.
7. PK-70873-0250 APPLIES.

REV.	REVISIONS
E	TRANSFER TO INDIA ECN U01 999-0929 SCHAFFER 99/04/20
D2	ADDED PART NO. PER ECN U6-0935 02/08/96 DRS
D1	ADDED PART NO. PER ECN U5-0148 09/01/94 DRS
D	MODIFIED PER ECN U2-1589 10-28-92 DRS
C1	ADDED NOTE #7 PER ECN U2-1007 07-06-92 DRS
C	MOD. WIRE SELECTION PER ECN U2-0873 06-08-92 DRS
B	MOD. WIRE SELECTION PER ECN U2-0716 05-07-92 DRS
A	X-RELEASE PER ECN U2-0581 04-15-92 DRS

DIMENSIONS SHOWN: INCH (METRIC)		MFG. SH. REV. LTR. REVISIONS	
UNLESS OTHERWISE SPECIFIED TOLERANCES ANGULAR ± 1/2°		REVISE ONLY ON CAD SYSTEM	
3 PLACE	INCH	TITLE	
2 PLACE	METRIC	SALES ASSEMBLY	
1 PLACE		4 CKT. POWER CONNECTOR	
DRAFT WHERE APPLICABLE MUST REMAIN WITHIN DIMENSIONS		MOLEX INCORPORATED U.S.A. SHEET NO. DATE	
SOURCE: SCHMIDGALLBY DWG: BIXLER		1 OF 2 06/30/89	
SCALE 4 : 1		PART NO. DRWG. NO.	
SEE CHART		SDA-70156-*****	
FILE NAME: STD15601		THIS DRAWING CONTAINS INFORMATION THAT IS PROPRIETARY TO MOLEX INC. AND SHOULD NOT BE USED WITHOUT WRITTEN PERMISSION.	
APP: BIXLER		CD C	

