

SECTION A-A

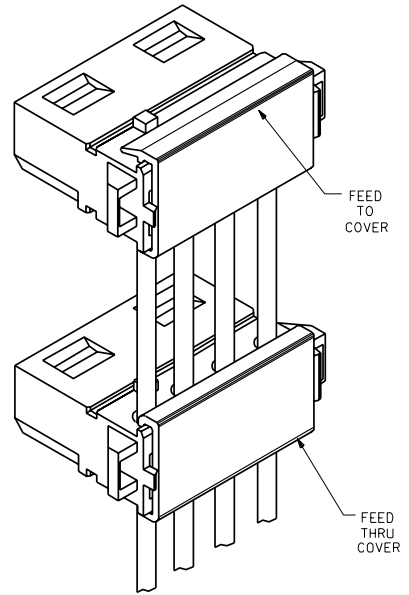

.0805±.0010  
(2.045±0.025)  
DIA.  
(TERMINAL BARREL)

NOTES:

1. ALL WIRES TO HAVE A MAX. DIAMETER OVER INSULATION OF .095/(2.41).
2. COVERS ARE SUGGESTED TO RETAIN WIRES. FEED TO DRAWING NO. SD-70156-4000. FEED THRU DRAWING NO. SD-70156-3000. SEE SHEET 2 FOR AVAILABLE KITS.
3. MATERIAL: HOUSING-NYLON, TYPE 6/6, 94V-2, COLOR: NATURAL  
HOUSING-POLYESTER, 94V-0  
COLOR: WHITE  
TERMINAL-PHOSPHOR BRONZE
4. .008/(0.20) MAX. VERTICAL PROJECTION DUE TO CARRIER CUT-OFF.
5. PS-70156-\*\*\*\*\* APPLIES.
6. SDES-70156 APPLIES.
7. PK-70873-0250 APPLIES.

REV.	REVISIONS
E	TRANSFER TO INDIA ECN U01 999-0929 SCHAFER 99/04/20
D2	ADDED PART NO. PER ECN U6-0935 02/08/96 DRS
D1	ADDED PART NO. PER ECN U5-0148 09/01/94 DRS
D	MODIFIED PER ECN U2-1589 10-28-92 DRS
C1	ADDED NOTE #7 PER ECN U2-1007 07-06-92 DRS
C	MOD. WIRE SELECTION PER ECN U2-0873 06-08-92 DRS
B	MOD. WIRE SELECTION PER ECN U2-0716 05-07-92 DRS
A	X-RELEASE PER ECN U2-0581 04-15-92 DRS

MFG. SH. REV. LTR. REVISIONS

**REVISE ONLY ON CAD SYSTEM**

SALES ASSEMBLY  
4 CKT. POWER CONNECTOR

MOLEX INCORPORATED	SHEET NO. 1 OF 2	DATE 06/30/89
SEE CHART	DRAWING NO. SDA-70156-*****	
FILE NAME: STD15601	SCALE: 4:1	SIZE: CD

DIMENSIONS SHOWN IN METRIC INCH UNLESS OTHERWISE SPECIFIED TOLERANCES ANGULAR ± 1/2°

INCH	METRIC
3 PLACE	----
2 PLACE	----
1 PLACE	----

DRAFT WHERE APPLICABLE MUST REMAIN WITHIN DIMENSIONS

DRAWN BY: SCHMIDGALLER DWG NO: BIXLER FILE NAME: STD15601 APP'D BY: BIXLER SCALE: 4:1

THIS DRAWING CONTAINS INFORMATION THAT IS PROPRIETARY TO MOLEX INC. AND SHOULD NOT BE USED WITHOUT WRITTEN PERMISSION.

						BLACK COVER			WHITE COVER	
PART NUMBER	ENG. NUMBER	PLATING CODE	COLOR STRIPE	RECOMMENDED WIRE TYPE	KIT PART NO.	KIT ENG. NO.	COVER TYPE	KIT PART NO.	KIT ENG. NO.	
15-24-3000	A-70156-2003	101	YELLOW	16 AWG STRANDED, UL STYLE #1007 ONLY	15-24-3001	MS-70156-2303	FEED THRU	15-24-2035	MS-70156-2503	
15-24-2000	A-70156-2000	101	RED	18 AWG STRANDED 20 AWG SOLID & FUSED STRANDED	15-24-3002	MS-70156-2403	FEED TO	15-24-2036	MS-70156-2603	
15-24-2001	A-70156-2001	101	BLUE	20 AWG STRANDED	15-24-2003	MS-70156-2300	FEED THRU	15-24-2037	MS-70156-2500	
15-24-2002	A-70156-2002	101	BLACK	22 AWG SOLID, FUSED STRANDED AND STRANDED	15-24-2004	MS-70156-2400	FEED TO	15-24-2038	MS-70156-2600	
15-24-3053	A-70156-5003	101	YELLOW	16 AWG STRANDED, UL STYLE #1007 ONLY	15-24-2005	MS-70156-2301	FEED THRU	15-24-2039	MS-70156-2501	
15-24-3050	A-70156-5000	101	RED	18 AWG STRANDED 20 AWG SOLID & FUSED STRANDED	15-24-2006	MS-70156-2401	FEED TO	15-24-2044	MS-70156-2601	
15-24-3051	A-70156-5001	101	BLUE	20 AWG STRANDED	15-24-2007	MS-70156-2302	FEED THRU	15-24-2045	MS-70156-2502	
15-24-3052	A-70156-5002	101	BLACK	22 AWG SOLID, FUSED STRANDED AND STRANDED	15-24-2008	MS-70156-2402	FEED TO	15-24-2046	MS-70156-2602	
NOT TOOLED	AX-70156-9003	554	YELLOW	16 AWG STRANDED, UL STYLE #1007 ONLY	15-24-3030	MS-70156-5303	FEED THRU	15-24-3009	MS-70156-5503	
15-24-2021	A-70156-9000	554	RED	18 AWG STRANDED	15-24-3031	MS-70156-5403	FEED TO	15-24-3013	MS-70156-5603	
NOT TOOLED	AX-70156-9001	554	BLUE	20 AWG SOLID, FUSED STRANDED AND STRANDED	15-24-3032	MS-70156-5300	FEED THRU	15-24-3014	MS-70156-5500	
NOT TOOLED	AX-70156-9002	554	BLACK	22 AWG SOLID, FUSED STRANDED AND STRANDED	15-24-3033	MS-70156-5400	FEED TO	15-24-3015	MS-70156-5600	
					15-24-3034	MS-70156-5301	FEED THRU	15-24-3016	MS-70156-5501	
					15-24-3035	MS-70156-5401	FEED TO	15-24-3017	MS-70156-5601	
					15-24-3036	MS-70156-5302	FEED THRU	15-24-3018	MS-70156-5502	
					15-24-3037	MS-70156-5402	FEED TO	15-24-3019	MS-70156-5602	
					NOT TOOLED	MSX-70156-9303	FEED THRU	NOT TOOLED	MSX-70156-9503	
					NOT TOOLED	MSX-70156-9403	FEED TO	NOT TOOLED	MSX-70156-9603	
					NOT TOOLED	MS-70156-9300	FEED THRU	NOT TOOLED	MS-70156-9500	
					NOT TOOLED	MS-70156-9400	FEED TO	NOT TOOLED	MS-70156-9600	
					NOT TOOLED	MSX-70156-9301	FEED THRU	NOT TOOLED	MSX-70156-9501	
					NOT TOOLED	MSX-70156-9401	FEED TO	NOT TOOLED	MSX-70156-9601	
					NOT TOOLED	MSX-70156-9303	FEED THRU	NOT TOOLED	MSX-70156-9503	
					NOT TOOLED	MSX-70156-9403	FEED TO	NOT TOOLED	MSX-70156-9603	
15-24-3003	A-70156-3000	101	NONE	18 AWG STRANDED 20 AWG SOLID & FUSED STRANDED	15-24-3004	MS-70156-3300	FEED THRU	15-24-3006	MS-70156-3500	
					15-24-3005	MS-70156-3400	FEED TO	15-24-3007	MS-70156-3600	

PLATING CODES:  
 101 - .000100/(.00254) MIN. TIN OVER  
 .000050/(.00127) MIN. COPPER  
 554 - .000015/(.00038) MIN. GOLD IN  
 CONTACT AREA OVER .000050/(.00127)  
 MIN. NICKEL OVERALL

E	SEE SHEET #1	UNLESS OTHERWISE SPECIFIED TOLERANCES ARE AS FOLLOWS:	SCALE	REVISE ONLY ON CAD SYSTEM
D2	SEE SHEET #1	FRACTIONAL DECIMALS	1:1	
D1	SEE SHEET #1	INCHES	1:1	
C1	SEE SHEET #1	MILLIMETERS	1:1	
C	SEE SHEET #1			
B	SEE SHEET #1			
A	SEE SHEET #1			

MOLEX INCORPORATED  
 SALES ASSEMBLY  
 4 CKT. POWER CONNECTOR  
 SEE CHART SDA-70156-0000  
 DATE 04/13/92  
 FILE NAME SDA-70156-0000  
 SCALE N/A

70156

A