

# Customer Information Sheet

DRAWING No.: M80-4C10205F1-02-325-00-000

SHEET 2 OF 2

IF IN DOUBT - ASK

(C)

NOT TO SCALE

THIRD ANGLE PROJECTION

ALL DIMENSIONS IN mm

## SPECIFICATIONS:

**MATERIAL:**  
 MOULDING: GLASS FILLED PPS, UL94V-0, BLACK  
**SIGNAL CONTACT:**  
 CLIP = BERYLLIUM COPPER  
 SHELL = BRASS  
**POWER CONTACT:**  
 BODY = COPPER ALLOY  
 LATCHING COLLAR = BERYLLIUM COPPER  
 JACKSCREW, CIRCLIP: STAINLESS STEEL  
**FINISH:**  
**SIGNAL CONTACT:**  
 CLIP = 0.3µ GOLD  
 SHELL = 0.25-0.3µ GOLD  
**POWER CONTACT:**  
 BODY = GOLD  
 LATCHING COLLAR = NICKEL  
**ELECTRICAL:**  
 WORKING VOLTAGE = 120V AC/DC  
 VOLTAGE PROOF = 360V AC/DC  
 INSULATION RESISTANCE = 100MΩ MIN  
**SIGNAL CONTACT:**  
 CURRENT RATING AT 25°C = 3.0A MAX  
 CURRENT RATING AT 85°C = 2.2A MAX  
 CONTACT RESISTANCE = 25 mΩ MAX  
**POWER CONTACT:**  
 CONTACT RESISTANCE = 6 mΩ MAX  
 CURRENT RATING = 20A MAX WITH 12AWG  
 CONTACT AS SPECIFIED  
**MECHANICAL:**  
 DURABILITY = 500 OPERATIONS  
**SIGNAL CONTACT:**  
 INSERTION FORCE = 2.8N MAX  
 WITHDRAWAL FORCE = 0.2N MIN  
**POWER CONTACT:**  
 INSERTION FORCE = 5N MAX  
 WITHDRAWAL FORCE = 0.5N MIN  
**ENVIRONMENTAL:**  
 TEMPERATURE RANGE = -55°C TO +125°C  
**PACKING:**  
 BAG  
 FOR COMPLETE SPECIFICATION SEE COMPONENT  
 SPECIFICATION C005XX (LATEST ISSUE)

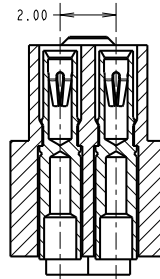
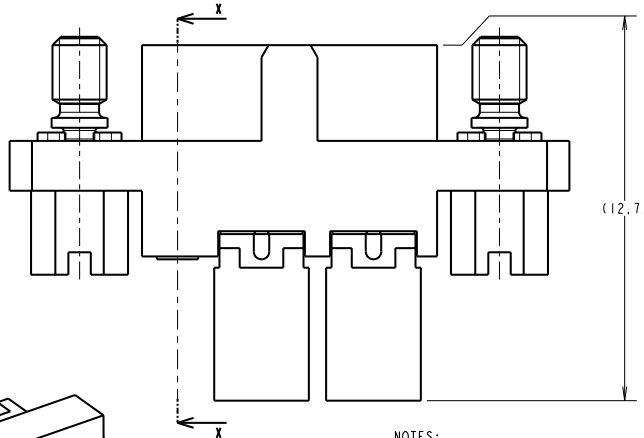
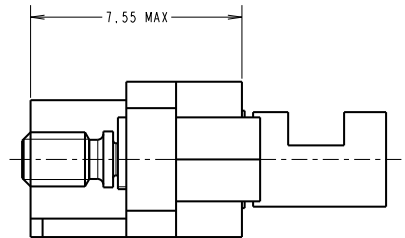
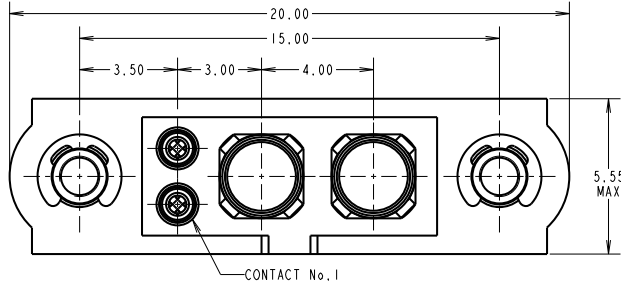

SECTION X-X

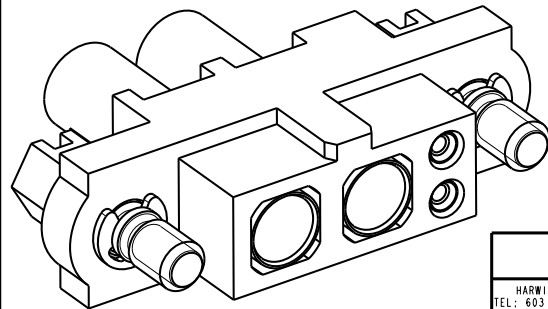

### NOTES:

- CONNECTORS ARE SUPPLIED WITH CONTACTS LOOSE.
- FOR EXTRA SIGNAL CONTACTS, USE PART NUMBER M80-0130005.
- RECOMMENDED SIGNAL WIRE TYPE = BS 3G 210 TYPE A, PTFE INSULATED 24-28 AWG. MAX INSULATION DIAMETER = Ø1.10mm. STRIP WIRE BY 2.00MM FOR CRIMPING.
- RECOMMENDED HAND CRIMP TOOL FOR SIGNAL CONTACTS = M22520/2-01 WITH POSITIONER T5747.
- SIGNAL CONTACT INSERTION AND EXTRACTION TOOL = Z80-280.
- FOR EXTRA POWER CONTACTS, USE PART NUMBER M80-325
- POWER CONTACT WIRE, STRIP BY 5.00mm MINIMUM
- POWER CONTACT EXTRACTION TOOL = Z80-290
- INSTRUCTION SHEETS ARE AVAILABLE.

SN	I	26.08.10	10806
NAME	ISS.	DATE	C/NOTE
APPROVED: S. MCCULLAGH			
CHECKED: R. ADDE			
DRAWN: R. ADDE			
CUSTOMER REF.:			
ASSEMBLY DRG:			

<b>HARWIN</b>			THIS DRAWING AND ANY INFORMATION OR DESCRIPTIVE MATTER SET OUT HEREON ARE CONFIDENTIAL AND COPYRIGHT PROPERTY OF THE HARWIN GROUP AND MUST NOT BE DISCLOSED, LOANED, COPIED OR USED FOR MANUFACTURING, TENDERING OR FOR ANY OTHER PURPOSE WITHOUT THE WRITTEN PERMISSION.	TOLERANCES	MATERIAL:	TITLE: JACKSCREW DATAMATE MIXED TECHNOLOGY CRIMP FEMALE ASSEMBLY
HARWIN USA TEL: 603 893 5376 FAX: 603 893 5396 mis@harwin.com	HARWIN Europe (UK) TEL: 023 9231 4545 FAX: 023 9231 4590 mis@harwin.co.uk	HARWIN Asia TEL: +65 6 779 4909 FAX: +65 6 779 3868 mis@harwin.com.sg		X. = ±1mm X.X = ±0.25mm X.XX = ±0.10mm X.XXX = ±0.01mm ANGLES = ±5° UNLESS STATED	SEE ABOVE	SEE ABOVE
S/AREA: mm²						SHT 2 of 2