

# 2.5mm Pitch Connector for Discrete Wire Connection

## HNC Series

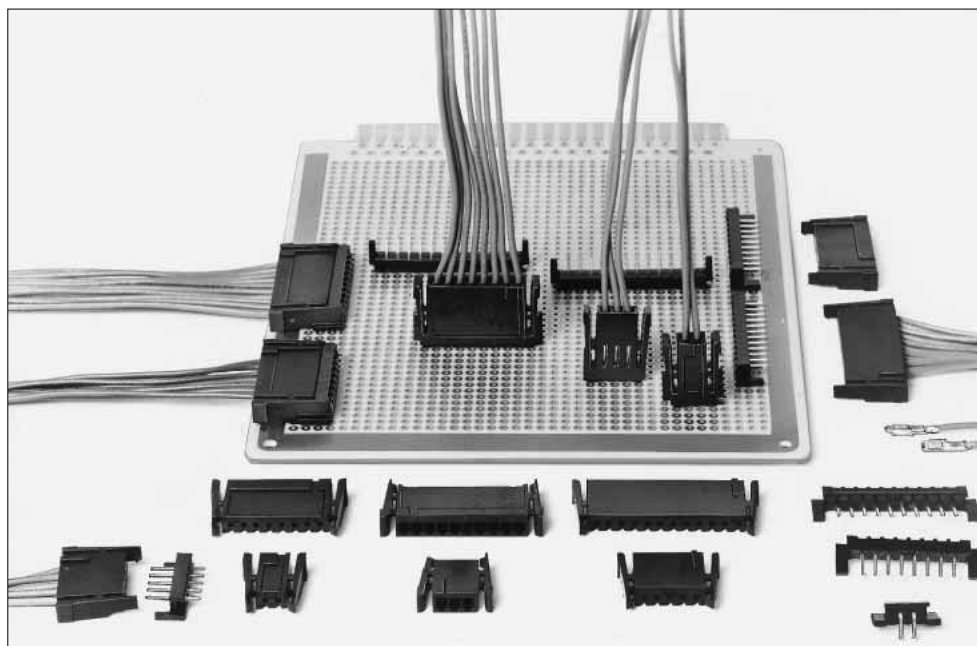

### ■ Features

#### 1. Full Lock Mechanism

The connector is equipped with the full lock mechanism so as not to be removed, unless locks are reset on both sides. This mechanism is activated effectively to prevent extraction by cable hooking or other causes.

#### 2. Thin Type Connector

Mounting height when the connector is used at the right angle : **4.8mm**

#### 3. Mechanism to Prevent Mis-insertion

This thin type connector is equipped with the mechanism to prevent mis-insertion.

#### 4. Tin Plating and Gold Plating Variation

Two kinds of tin plating and gold plating types are available, and can be chosen according to application. The tin plating is also set to a light operating touch.

### ■ Applications

Various business equipment, financial terminals

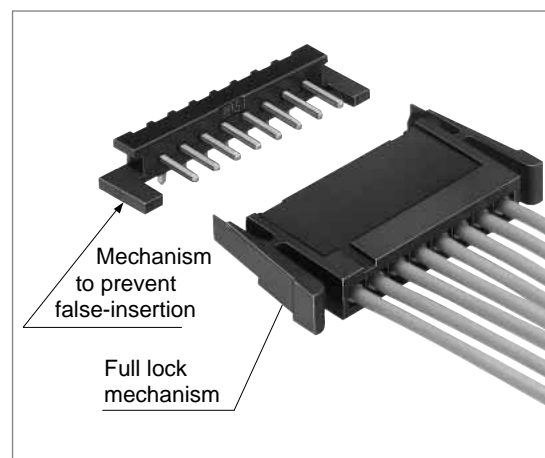

## HNC Series 2.5mm Pitch Connector for Discrete Wire Connection

### Product Specifications

Rating	Current rating (Note1)	AWG 22 : 3A AWG 24 : 3A AWG 26 : 2A AWG 28 : 1A AWG 30 : 0.5A	Operating Temperature Range Operating Moisture Range	-25 to +85°C (Note2) 40 to 80%
	Voltage rating	250V AC	Storage Temperature Range Storage Moisture Range	-10 to +60°C (Note3) 40 to 70% (Note3)

Item	Specification	Condition
1. Insulation Resistance	1000M ohms min.	500V DC
2. Withstanding voltage	No flashover or insulation breakdown.	1000V AC/1 minute
3. Contact Resistance	10m ohms Max	1A
4. Insertor/Extraction Force	0.4N (40gf) min., 4.4N (450gf) max.	Measure at the square steel pin of 0.635±0.002mm
5. Vibration	No electrical discontinuity of 1μs or more	Frequency: 10 to 55 Hz, single amplitude of 0.75 mm, 2 hours in each of the 3 directions.
6. Humidity (Steady state)	Contact resistance: 10m ohms max. Insulation resistance: 1000M ohms min.	96 hours at temperature of 40±2°C and humidity of 90% to 95%
7. Temperature Cycle	Contact resistance: 10m ohms max. Insulation resistance: 1000M ohms min.	(-25°C: 30 minutes → 5 to 35°C: 10 minutes 85°C: 30 minutes → 5 to 35°C: 10 minutes) 5 cycles
8. Durability (Mating/un-mating)	Contact resistance: 20m ohms max.	Tin plating : 30 cycles Gold plating : 50 cycles
9. Resistance to Soldering heat	No deformation of components affecting performance.	Flow: 250°C for 5 seconds
		Manual soldering: 300°C for 2 seconds

Note 1: The rated current will be changed according to cable sizes for use. The header rating only t is 3A.

Note 2: Includes temperature rise caused by current flow.

Note 3: The term "storage" refers to products stored for long period of time prior to mounting and use. Operating Temperature Range and Humidity range covers non conducting condition of installed connectors in storage, shipment or during transportation.

Note 4: Information contained in this catalog represents general requirements for this Series. Contact us for the drawings and specifications for a specific part number shown.

### Material

Product	Part	Material	Finish	Remarks
Crimping Socket	Insulator	Polyamide	Black	UL94V-2
Contact	Contact	Phosphor Bronze	Tin plated or gold plated	—
Pin Header	Insulator	Polyamide	Black	UL94V-2
	Contact	Brass	Tin plated or gold plated	—

### Ordering Information

#### ●Crimping Plug

**HNC 2 - 2.5 P - \* DSL**

①      ②      ③      ④      ⑤      ⑥

① Series Name : HNC	⑤ Number of Contacts : 2 to 8,10,12,15
② Series No. : 2, 1	⑥ Contact Type None : Crimping socket DS : Straight DSL : Right angle
③ Contact Pitch : 2.5mm	
④ Connector Type S : Socket P : Pin Header	

#### ●Contact

**HNC - 2.5S - C - A**

①      ②      ③

① Type: 2.5mm pitch socket	③ Applicable cable size A : AWG22 to 26 B : AWG26 to 30
② Packaging Type C : Reel D : Bag	

## ■ Crimping Socket



[Figure 1]

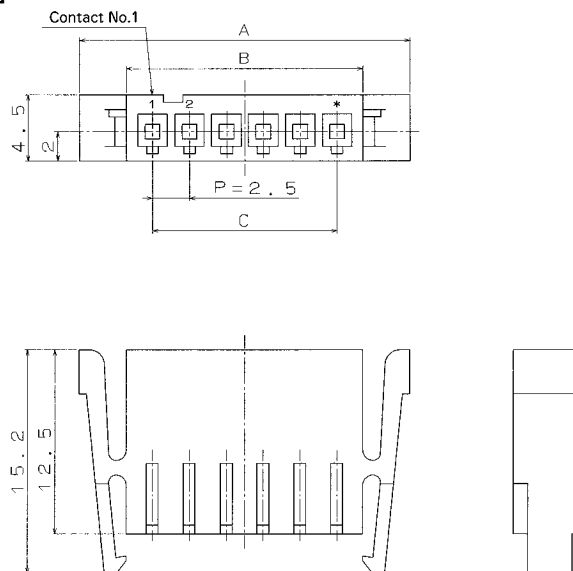

[Figure 2]

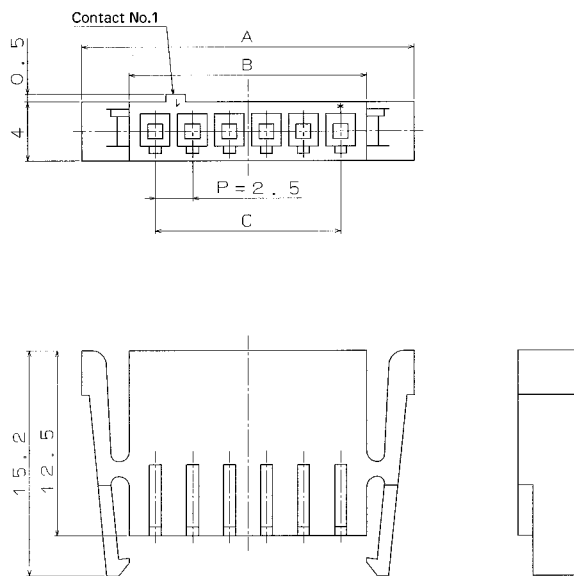

Unit: mm

Part Number	CL No.	Number of Contacts	A	B	C	Dimensions	RoHS
HNC2-2.5S- 2	218-0011-1	2	12.4	6	2.5	Figure 1	Yes
HNC2-2.5S- 3	218-0022-8	3	14.9	8.5	5		
HNC2-2.5S- 4	218-0039-0	4	17.4	11	7.5		
HNC2-2.5S- 5	218-0027-1	5	19.9	13.5	10		
HNC2-2.5S- 6	218-0042-5	6	22.4	16	12.5		
HNC2-2.5S- 7	218-0030-6	7	24.9	18.5	15		
HNC2-2.5S- 8	218-0014-0	8	27.4	21	17.5		
HNC2-2.5S-10	218-0017-8	10	32.4	26	22.5		
HNC1-2.5S-12	218-0008-7	12	37	31	27.5	Figure 2	
HNC2-2.5S-15	218-0045-3	15	44.9	38.5	35	Figure 1	

Note1: Please order a quantity multiplied by 100 pcs. (Not per bag, but per pcs.)

Note2: The series name of 12 contacts connector is HNC1, and partially will be changed in the style.

HNC Series 2.5mm Pitch Connector for Discrete Wire Connection

## ■ Straight Pin Header

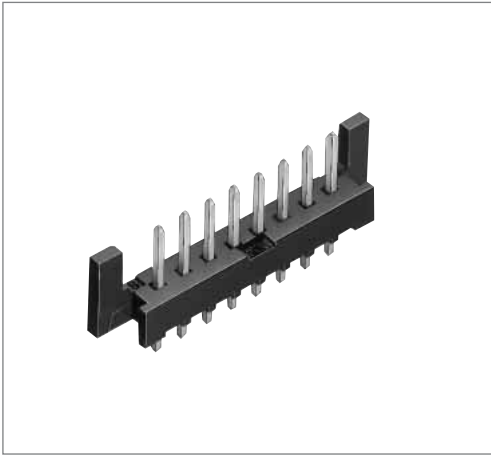

●Board Through-hole Diameter:  $\phi 1.1^{+0.1}$

[Figure 3]

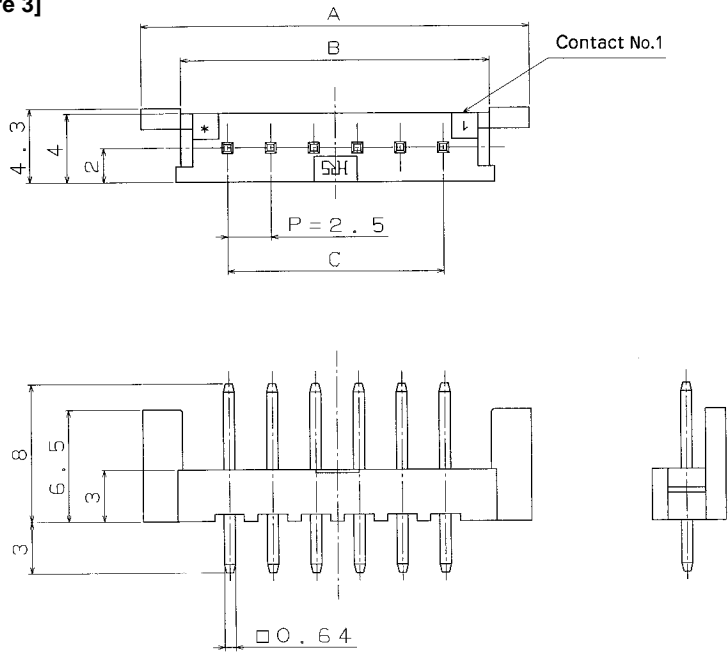

[Figure 4]

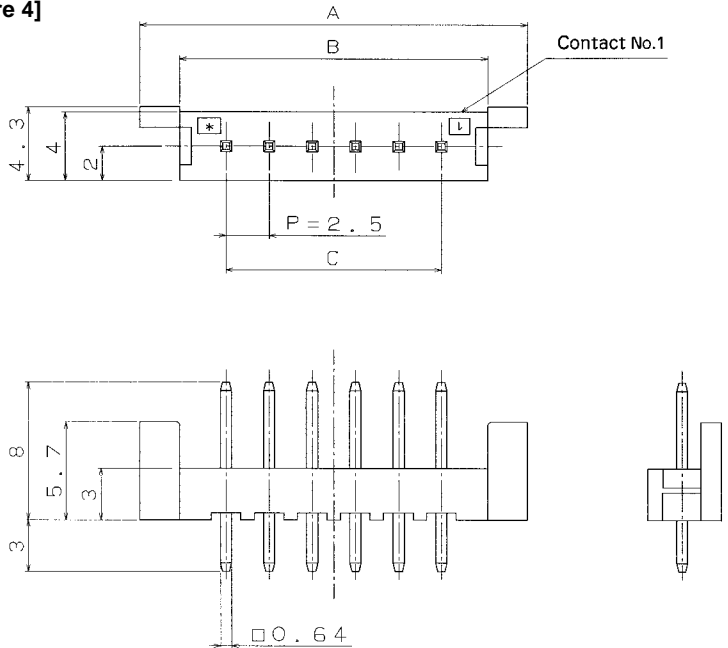

Unit: mm

Part Number	CL No.	Number of Contacts	A	B	C	Specific No.		Dimensions	RoHS
						Tin plating	Gold plating		
HNC2-2.5P- 2DS(**)	218-0012-4-**	2	12.5	7.8	2.5	55	02	Figure 3	Yes
HNC2-2.5P- 3DS(**)	218-0023-0-**	3	15	10.4	5	55	02		
HNC2-2.5P- 4DS(**)	218-0040-0-**	4	17.5	12.9	7.5	55	01		
HNC2-2.5P- 5DS(**)	218-0028-4-**	5	20	15.4	10	55	02		
HNC2-2.5P- 6DS(**)	218-0043-8-**	6	22.5	17.9	12.5	55	01		
HNC2-2.5P- 7DS(**)	218-0031-9-**	7	25	20.4	15	55	02		
HNC2-2.5P- 8DS(**)	218-0015-2-**	8	27.5	22.8	17.5	55	02		
HNC2-2.5P-10DS(**)	218-0018-0-**	10	32.5	27.8	22.5	55	02	Figure 4	Yes
HNC1-2.5P-12DS(**)	218-0009-0-**	12	35.5	32.8	27.5	55	02		
HNC2-2.5P-15DS(**)	218-0046-6-**	15	45	40.4	35	55	01	Figure 3	Yes

Note1: Please order a quantity multiplied by 100 pcs. (Not per bag, but per piece)

Note2: The series name of the 12 contacts connector is HNC1 and the style will be partially changed.

## Right Angle Pin Header [Figure 5]

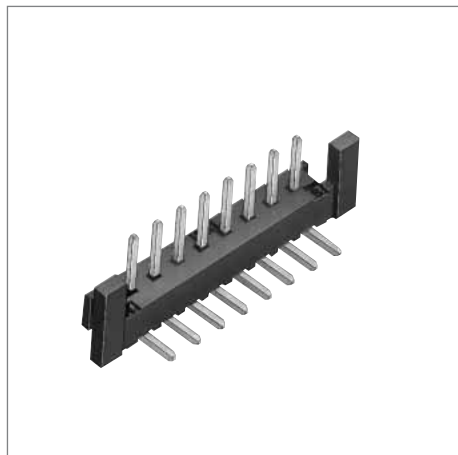

●Board Through-hole Diameter:  $\varnothing 1.1^{+0.1}$

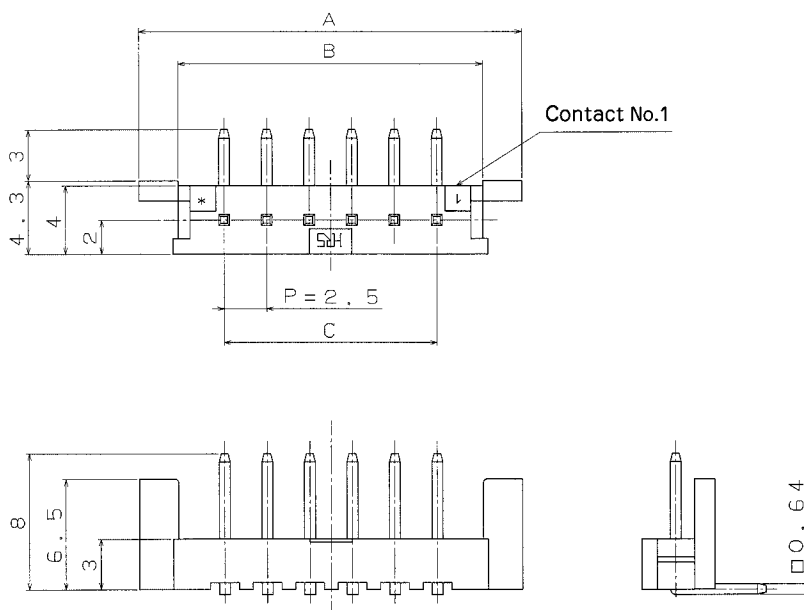

[Figure 6]

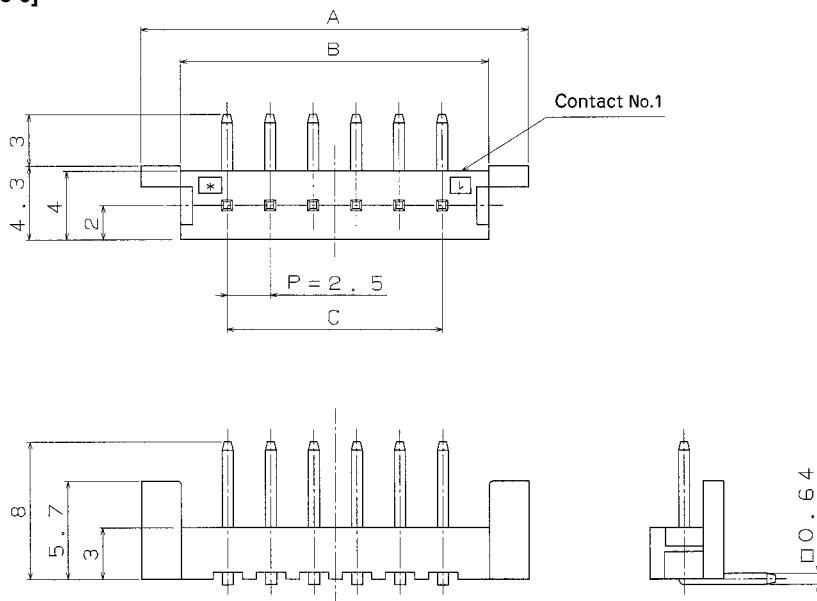

Unit: mm

Part Number	CL No.	Number of Contacts	A	B	C	Specific No.		Dimensions	RoHS
						Tin plating	Gold plating		
HNC2-2.5P- 2DSL(**)	218-0013-7-**	2	12.5	7.8	2.5	55	02	Figure 5	Yes
HNC2-2.5P- 3DSL(**)	218-0024-3-**	3	15	10.4	5	55	02		
HNC2-2.5P- 4DSL(**)	218-0041-2-**	4	17.5	12.9	7.5	55	01		
HNC2-2.5P- 5DSL(**)	218-0029-7-**	5	20	15.4	10	55	02		
HNC2-2.5P- 6DSL(**)	218-0044-0-**	6	22.5	17.9	12.5	55	01		
HNC2-2.5P- 7DSL(**)	218-0032-1-**	7	25	20.4	15	55	02		
HNC2-2.5P- 8DSL(**)	218-0016-5-**	8	27.5	22.8	17.5	55	02		
HNC2-2.5P-10DSL(**)	218-0019-3-**	10	32.5	27.8	22.5	55	02	Figure 6	Yes
HNC1-2.5P-12DSL(**)	218-0010-9-**	12	35.5	32.8	27.5	55	02		
HNC2-2.5P-15DSL(**)	218-0047-9-**	15	45	40.4	35	55	01	Figure 5	Yes

Note1: Please order a quantity multiplied by 100 pcs. (Not per bag, but per piece)

Note2: The series name of the 12 contacts connector is HNC1 and the style will be partially changed.

## HNC Series 2.5mm Pitch Connector for Discrete Wire Connection

### ■Crimping Contact for Socket

#### ●Applicable Cable (Tin Plated Annealing Copper Wire)

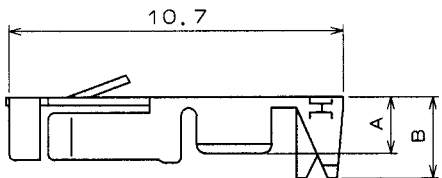

Conductor Size (Contact wire construction)	Jacket Diameter
AWG 22 (17pieces/0.16mm)	φ1.35 to φ1.7mm
AWG 24 (11pieces/0.16mm)	
AWG 26 ( 7pieces/0.16mm)	
AWG 28 ( 7pieces/0.127mm)	φ1.0 to φ1.35mm
AWG 30 ( 7pieces/0.1mm)	

#### ●Recommended Cable

UL1061, UL1007

#### ●Strip Length

2.8 to 3.3mm

Note: If other cables are used instead of the applicable cable, please contact Hirose sales department.

Unit: mm

Part Number	CL No.	Conductor Size	Jacket Diameter	A	B	Packaging Type	Quantity	Specific No.		RoHS
								Tin plating	Gold plating	
HNC-2.5S-D-A(**)	218-0037-5-***	AWG 22 to 26	φ1.35 to 1.7mm	1.8	2.6	Bag	100	15	02	Yes
HNC-2.5S-C-A(**)	218-0021-5-***			1.8	2.6	Reel	10,000			
HNC-2.5S-D-B(**)	218-0038-8-***	AWG 26 to 30	φ1.0 to 1.35mm	1.5	1.7	Bag	100			
HNC-2.5S-C-B(**)	218-0020-2-***			1.5	1.7	Reel	10,000			

### ■Applicable Crimping Tool

Type	Part Number	CL No.	Applicable Contact
Applicator	AP105-HNC	901-4502-0	HNC-2.5S-C-A(**)/HNC-2.5S-C-B(**)
Press Main Unit	CM105	901-0005-4	
Manual Crimping Tool	TC-HNC-B	250-0005-7	HNC-2.5S-D-B(**)
	TC-HNC-A	250-0006-0	HNC-2.5S-D-A(**)
Extraction Tool	DF1-C-PO	550-0177-7	HNC-2.5S-C-A/HNC-2.5S-C-B(**)

Note: If a trouble has occurred due to tools which are not designated by Hirose, Hirose won't guarantee any product.

### ■Application Pattern

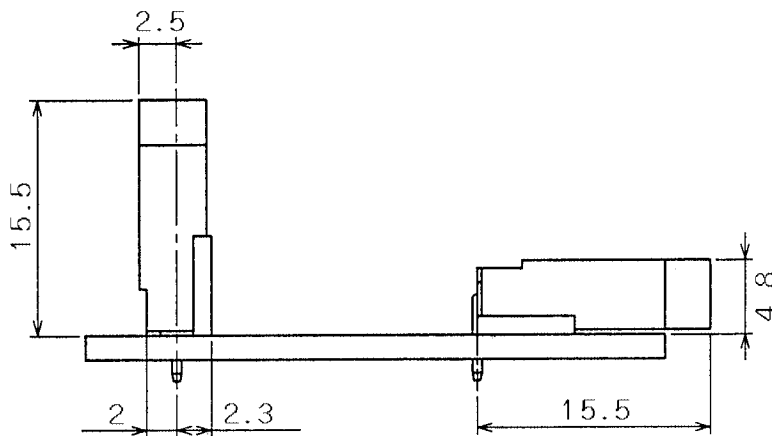

## ◆ Precautions

1. Recommended Soldering Condition	Flow: 250°C for 5 seconds Manual soldering: 300°C for 2 seconds
2. Cleaning Condition	Refer to Nylon Connector Use Hand book.
3. Connection Condition	Refer to Nylon Connector Use Hand book.