

MATERIAL NUMBER	WIRE SIZE	PLATING OPTION	LUBRICATION	MAX INSULATION	"A" ±.012 +0.30	"B" ±.012 +0.30	"C" ±.012 +0.30	"D" ±.012 +0.30
46235-0001	20-24	1	NO	.073	.091	.098	.068	.073
46235-0002		2		1.85	2.30	2.48	1.73	1.93
46235-0003	1	YES		.050	.075	.090	.048	.069
46235-0004	2			1.27	1.90	2.29	1.22	1.75
46235-5001	20-24	1	YES	.073	.091	.098	.068	.073
46235-5002		2		1.85	2.30	2.48	1.73	1.93
46235-5003	1	YES		.050	.075	.090	.048	.069
46235-5004	2			1.27	1.90	2.29	1.22	1.75

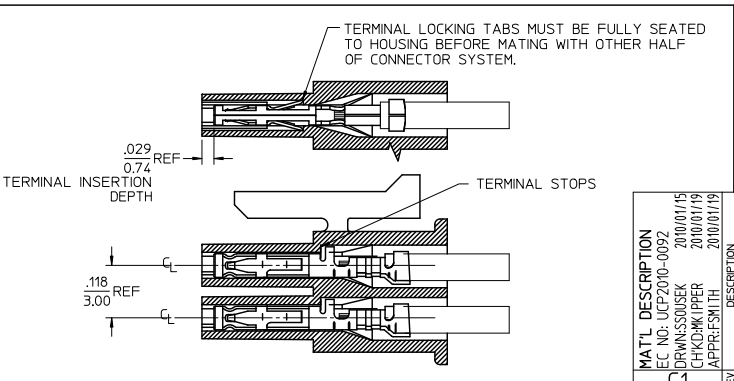
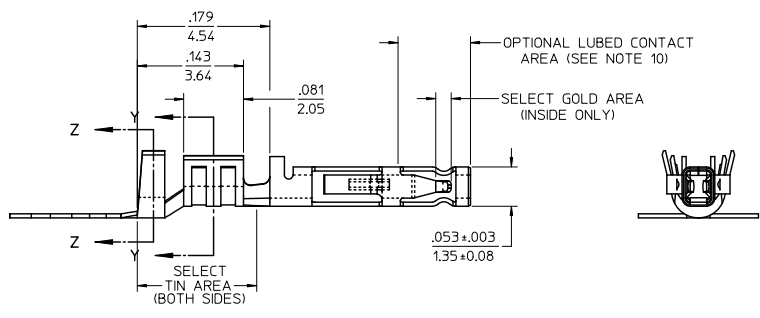
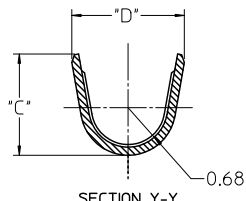
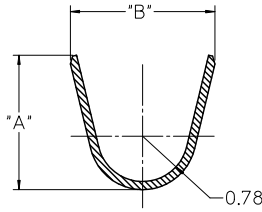
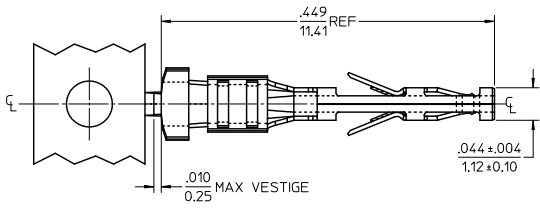

- NOTES
- 1) MATERIAL: COPPER ALLOY
 - 2) TERMINAL PLATING:
 - 1) .000015/0.00038 MIN. SELECT GOLD .000100/0.00254 MIN. SELECT TIN ALL OVER .000050/0.00127 MIN. NICKEL OVERALL.
 - 2) .000030/0.00076 MIN. SELECT GOLD .000100/0.00254 MIN. SELECT TIN ALL OVER .000050/0.00127 MIN. NICKEL OVERALL.
 - 3) PRODUCT SPECIFICATION: PS-46235-001
 - 4) PACKAGING SPECIFICATION: PK-46235-001
 - 5) TERMINAL FOR USE IN RECEPTACLE SERIES 43025, 43645 AND 44133.
 - 6) FOR TERMINAL ORIENTATION IN RECEPTACLE SEE PICTORIAL IN LOWER LEFT CORNER
 - 7) THIS TERMINAL IS DESIGNED IN METRIC
 - 8) MOLEX RECOMMENDS THE USE OF MICRO-FIT TEST PLUG (SERIES 44242) WHENEVER CONTINUITY TESTING IS PERFORMED. TEST PLUGS MUST NOT BE USED TO MAKE OR BREAK UNDER LOAD. MOLEX DOES NOT RECOMMEND USING STANDARD MATING COMPONENTS (SERIES 43020, 43045, 43640, 43650, OR 43031) FOR HARNESS TESTING PURPOSES
 - 9) THIS PART CONFORMS TO CLASS B REQUIREMENTS OF COSMETIC SPEC PS-45499-002
 - 10) MOLEX PROPRIETARY CONTACT LUBRICATION EB-1 IS APPLIED IN THE CONTACT AREA AS SHOWN. SEE CHART FOR APPLICABLE PART NUMBERS.

MAT'L DESCRIPTION EC NO. UCE2010-0092 DRWNSOUSEK 2010/01/15 CHKCHKI PPKR 2010/01/19 APPR:SMITH 2010/01/19	QUALITY SYMBOLS 	GENERAL TOLERANCES (UNLESS SPECIFIED)		DIMENSION STYLE IN/MM		SCALE 10:1	DESIGN UNITS METRIC	THIRD ANGLE PROJECTION
		4 PLACES ±.010 ±.010 3 PLACES ±.010 ±.010 2 PLACES ±.025 ±.014 1 PLACE ±.035 ±.014	mm INCH	DRAWN BY T.GREGORI	DATE 2007/02/05	TITLE MICRO-FIT (3.0) FEMALE CRIMP TERMINAL LOW MATE FORCE		
DRAFT WHERE APPLICABLE MUST REMAIN WITHIN DIMENSIONS	SIZE SEE CHART	APPROVED BY JCOMERC I		DATE 2007/03/19		MATERIAL NO. SD-46235-001		
		ANGULAR ±1/2°		APPROVED BY JCOMERC I		DATE 2007/03/19		DOCUMENT NO. SD-46235-001