

13 12 11 10 9 8 7 6 5 4 3 2 1

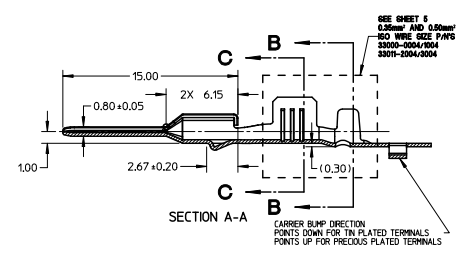

GENERAL NOTES: (UNLESS OTHERWISE SPECIFIED)

- MATING TERMINAL SHOWN ON SD-33012-002
- MATERIAL: ASTM B422, UNS C19025, HR04  
THICKNESS: 0.30 mm ±0.01  
TEMPER: FULL HARD (REF)  
TENSILE: 496-572 MPA
- TIN PLATED TERMINAL FINISH:  
OVERALL UNDERPLATE ELECTRODEPOSITED NICKEL  
OVERALL ELECTRODEPOSITED REFLOW TIN
- GOLD PLATED TERMINAL FINISH:  
OVERALL UNDERPLATE ELECTRODEPOSITED DUCTILE SULFAMATE NICKEL  
CONTACT AREA - ELECTRODEPOSITED GOLD  
GRIP AREA - ELECTRODEPOSITED 100% TIN MATTE FINISH
- SILVER PLATED TERMINAL FINISH:  
OVERALL UNDERPLATE ELECTRODEPOSITED DUCTILE SULFAMATE NICKEL  
CONTACT AREA - ELECTRODEPOSITED PURE SILVER (0.5% MAX IMPURITIES) SEM-BRIGHT FINISH  
GRIP AREA - ELECTRODEPOSITED 100% TIN MATTE FINISH
- MEETS CRMP PERFORMANCE SPECIFICATION SAE/J1773 (RELEASED: 08/25/01)
- MEETS PERFORMANCE STANDARD FOR AUTOMOTIVE ELECTRICAL CONNECTOR SYSTEMS SAE/J1773-2 REV 3 (APRIL 2001)
- MEETS FIELD CORRELATED LIFE TEST SAE/J1773-2 (NOVEMBER 2001)
- MEETS WIRING COMPONENT DESIGN GUIDELINES SAE/J1773-2 REV 2 (DECEMBER 2001)
- MEETS ELECTRICAL CONNECTION SYSTEM DESIGN SPECIFICATION (SDS) REV 11 (5/2002)
- REFERENCE PK-31900-516 FOR REEL DIRECTION
- REFERENCE AS-33000-001 FOR CRMP INFORMATION

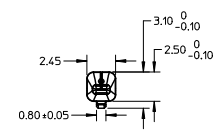
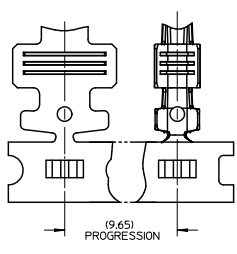
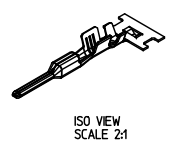
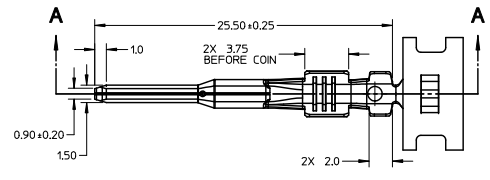
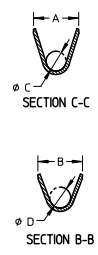
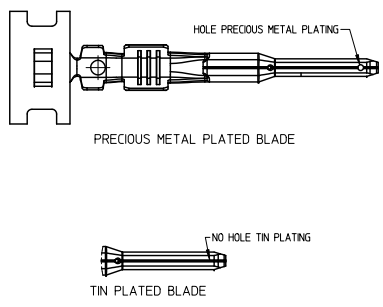

ENTER DESCRIPTION EC NO.: UAU201-0539 DRAWN: HENOS 2011/01/12 CHKD: APPR: BMOSE 2011/01/20	QUALITY SYMBOLS ▽=0 ▽=0 ▽=0	GENERAL TOLERANCES (UNLESS SPECIFIED)		DIMENSION STYLE		SCALE	DESIGN UNITS	THIRD ANGLE PROJECTION
		mm	INCH	MM ONLY	DATE	4:1	METRIC	
C11	DESCRIPTION	4 PLACES ±---	±---	DRAWN BY	2006/01/31	TITLE		
		3 PLACES ±---	±---	L. PULLIAM	2006/01/31	MX150 15MM BLADE TERMINAL		
		2 PLACES ±0.1	±---	CHECKED BY	DATE			
		1 PLACE ±0.3	±---	A. DHIR	2006/02/01			
		ANGULAR ± 3 °	±---	APPROVED BY	DATE			
				B. MOSE	2006/02/02			
DRAFT WHERE APPLICABLE MUST REMAIN WITHIN DIMENSIONS		SEE TABLE		MATERIAL NO.		DOCUMENT NO.	SHEET NO.	
				SD-33000-001		1 OF 5		

12 11 10 9 8 7 6 5 4 3 2 1

13 12 11 10 9 8 7 6 5 4 3 2 1

TABLE

SUPPLIER PART NUMBER		PLATING	GRIP CODE	WIRE APPLICATION		A ±0.30	B ±0.30	C ±0.30	D ±0.30	COMMENTS
RIGHT PAYOFF DIRECTION B	LEFT PAYOFF DIRECTION D			SAE (AWG)	METRIC (mm <sup>2</sup> )					
33000-0001	33000-1001	TIN	14	14	2.0-15	3.9	3.8	1.7	1.6	
33000-0002	33000-1002	TIN	18	16/18/20	1.0-0.75	3.3	3.1	1.3	1.4	
33000-0003	33000-1003	TIN	22	22	0.35-0.50	2.5	2.6	0.9	1.0	
33000-0004	33000-1004	TIN	M3	N/A	0.35-0.50	2.5	2.7	0.9	154±0.1	PREFERRED TERMINAL FOR USE IN SEALED APPLICATION WITH 0.35& 0.50 WIRES (OD 1.2-1.7mm)
33011-1002	33011-0002	GOLD	14	14	2.0-15	3.9	3.8	1.7	1.6	
33011-1004	33011-0004	GOLD	18	16/18/20	1.0-0.75	3.3	3.1	1.3	1.4	
33011-1006	33011-0006	GOLD	22	22	0.35-0.50	2.5	2.6	0.9	1.0	
33011-2003	33011-3003	SILVER	14	14	2.0-15	3.9	3.8	1.7	1.6	NOT TO BE USED IN CONNECTOR SYSTEMS WITH CIRCUIT COUNTS HIGHER THAN 8 DUE TO HIGHER CONNECTOR MATE/UNMATE FORCE
33011-2002	33011-3002	SILVER	18	16/18/20	1.0-0.75	3.3	3.1	1.3	1.4	
33011-2001	33011-3001	SILVER	22	22	0.35-0.50	2.5	2.6	0.9	1.0	
33011-2004	33011-3004	SILVER	M3	N/A	0.35-0.50	2.5	2.7	0.9	154±0.1	PREFERRED TERMINAL FOR USE IN SEALED APPLICATION WITH 0.35& 0.50 WIRES (OD 1.2-1.7mm) USE IN CLASS 3 (125° C) APPLICATIONS ONLY

ENTER DESCRIPTION EC NO: UAJ201-0559 DRAWN: RENUS 2011/01/12 CHKD: APPR: BMOSER 2011/01/20 C11	QUALITY SYMBOLS	GENERAL TOLERANCES (UNLESS SPECIFIED)	DIMENSION STYLE	SCALE	DESIGN UNITS	THIRD ANGLE PROJECTION
	▽=0	mm INCH	MM ONLY		METRIC	
	▽=0	4 PLACES ±--- ±---	DRAWN BY DATE	TITLE		
	▽=0	3 PLACES ±--- ±---	L. PULLIAM 2006/01/31	MX150 15MM BLADE TERMINAL		
▽=0	2 PLACES ±0.1 ±---	CHECKED BY DATE	MOLEX INCORPORATED			
	1 PLACE ±0.3 ±---	A. DHIR 2006/02/01	SD-33000-001			
	ANGULAR ± 3 °	APPROVED BY DATE	SHEET NO. 2 OF 5			
		B. MOSER 2006/02/02	THIS DRAWING CONTAINS INFORMATION THAT IS PROPRIETARY TO MOLEX INCORPORATED AND SHOULD NOT BE USED WITHOUT WRITTEN PERMISSION			
	DRAFT WHERE APPLICABLE MUST REMAIN WITHIN DIMENSIONS	MATERIAL NO.	SEE TABLE			
		DOCUMENT NO.	C			

1b\_frame\_C.P.AM.T Rev. F 2009/06/18 12 11 10 9 8 7 6 5 4 3 2 1

13 12 11 10 9 8 7 6 5 4 3 2 1

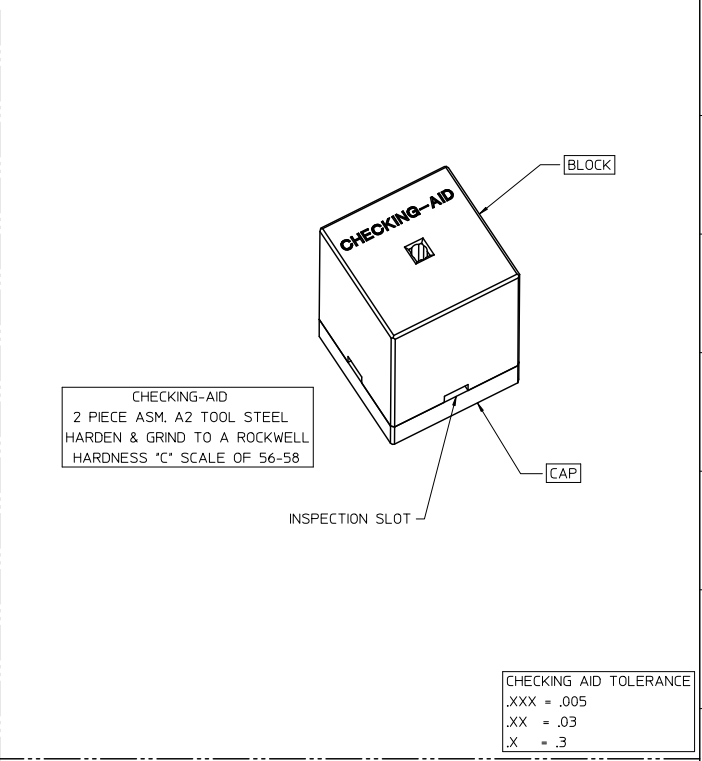
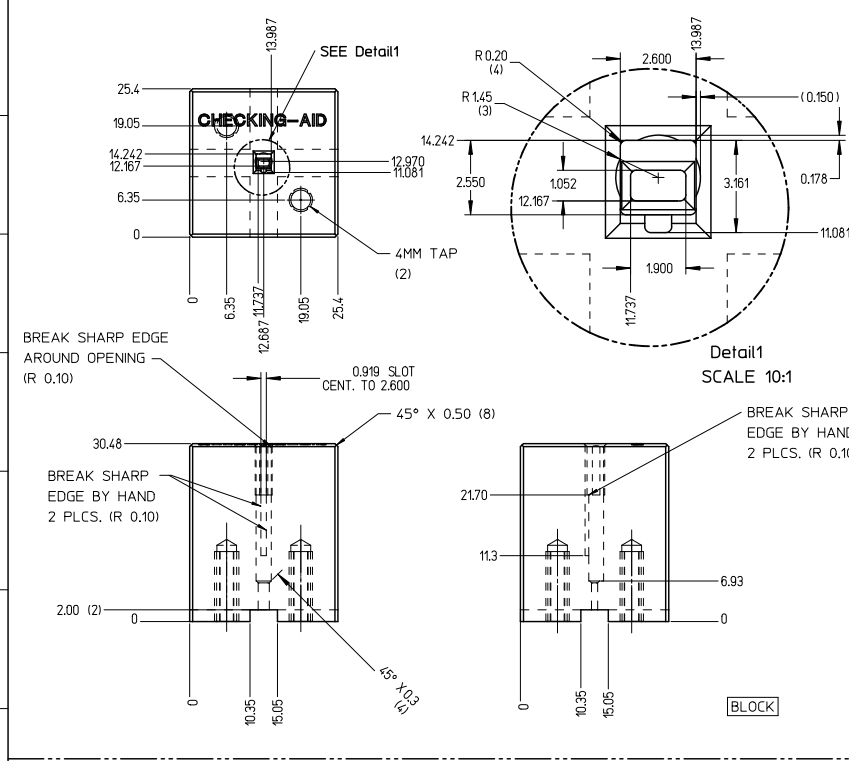

CHECKING AID TOLERANCE	
.XXX	= .005
.XX	= .03
.X	= .3

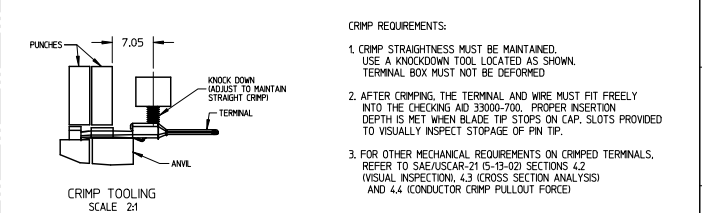
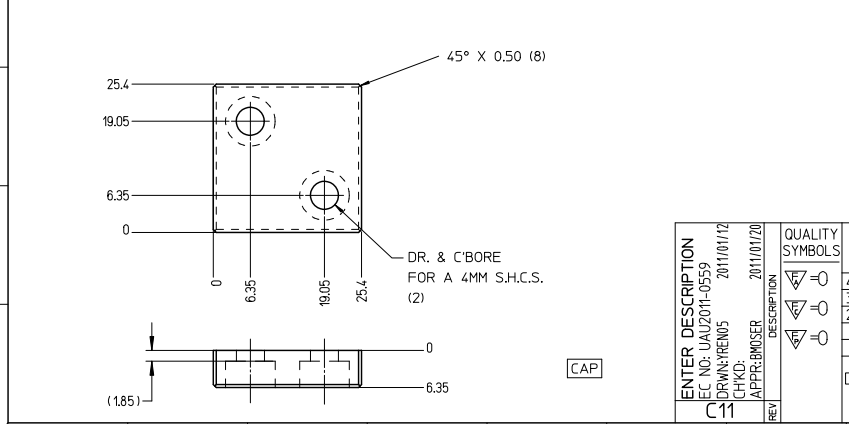

- CRIMP REQUIREMENTS:**
1. CRIMP STRAIGHTNESS MUST BE MAINTAINED. USE A KNOCKDOWN TOOL LOCATED AS SHOWN. TERMINAL BOX MUST NOT BE DEFORMED.
  2. AFTER CRIMPING, THE TERMINAL AND WIRE MUST FIT FREELY INTO THE CHECKING AID 33000-700. PROPER INSERTION DEPTH IS MET WHEN BLADE TIP STOPS ON CAP. SLOTS PROVIDED TO VISUALLY INSPECT STOPPAGE OF PIN TIP.
  3. FOR OTHER MECHANICAL REQUIREMENTS ON CRIMPED TERMINALS, REFER TO SAE/USCAR-21 (5-15-02) SECTIONS 4.2 (VISUAL INSPECTION), 4.3 (CROSS SECTION ANALYSIS) AND 4.4 (CONDUCTOR CRIMP PULLOUT FORCE)

<b>ENTER DESCRIPTION</b> EC NO: UAU201-0559 DRAWN: HENUS 2011/01/12 CHKD: APPR: BMOSER 2011/01/20 C11	<b>QUALITY SYMBOLS</b> 	<b>GENERAL TOLERANCES (UNLESS SPECIFIED)</b>		<b>DIMENSION STYLE</b> MM ONLY		SCALE 2:1	DESIGN UNITS METRIC	THIRD ANGLE PROJECTION	
		4 PLACES ± .01 ± .005 3 PLACES ± .01 ± .005 2 PLACES ± .01 ± .005 1 PLACE ± .03 ± .005	mm INCH	DRAWN BY L. PULLIAM 2006/01/31	DATE 2006/01/31	TITLE MX150 15MM BLADE TERMINAL			
		ANGULAR ± 3°	DRAFT WHERE APPLICABLE MUST REMAIN WITHIN DIMENSIONS	CHECKED BY A. DHIR 2006/02/01	DATE 2006/02/01	APPROVED BY B. MOSER 2006/02/02			
		MATERIAL NO. SD-33000-001	SIZE SEE TABLE	THIS DRAWING CONTAINS INFORMATION THAT IS PROPRIETARY TO MOLEX INCORPORATED AND SHOULD NOT BE USED WITHOUT WRITTEN PERMISSION		MOLEX INCORPORATED DOCUMENT NO.	SHEET NO. 3 OF 5		

tb\_frame\_C\_P\_AM\_T Rev. F 2009/06/18 12 11 10 9 8 7 6 5 4 3 2 1

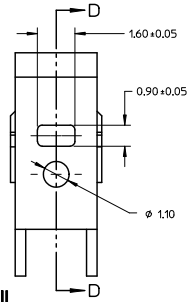
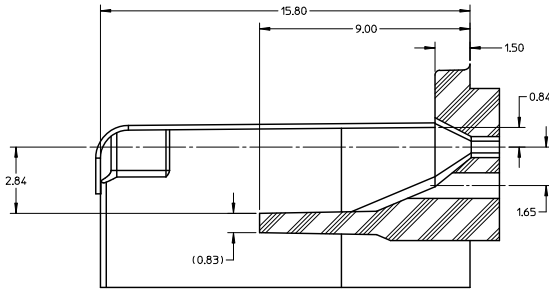
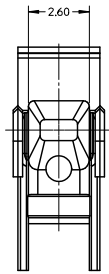

SECTION D-D TPA/INSERT DETAIL

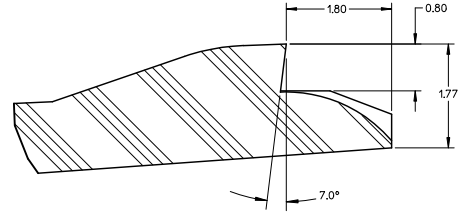
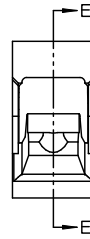
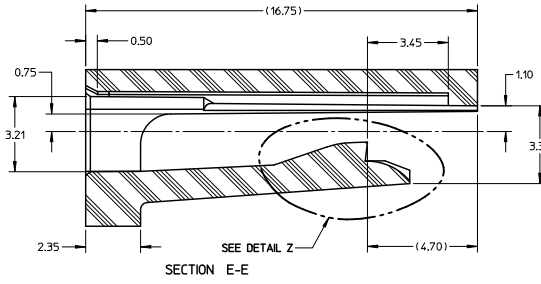
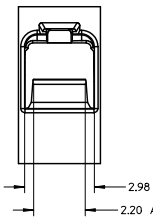

DETAIL Z SCALE 20:1

HOUSING DETAIL

- NOTES: (UNLESS OTHERWISE SPECIFIED)
1. TOLERANCES: LINEAR  $\pm 0.10$   
ANGULAR  $3^\circ$
  2. ALL DRAFT WITHIN TOLERANCE
  3. MAX RADI ON ALL CORNERS SHOWN SHARP: 0.10
  4. MAX FLASH PERMISSIBLE: 0.1
  5. EJECTOR PIN MARKS PERMISSIBLE IF FLUSH TO 0.25 BELOW SURFACE
  6. MATERIAL: HOUSING/FINGER SPECIFICATION ENGINEERED FOR MATERIAL WITH THE FOLLOWING PROPERTIES:  
A. FLEXURAL MODULUS = 4500 TO 9400 MPa  
PER ASTM TEST D790  
B. ELONGATION AT YIELD = 2.3% OR BETTER  
PER ASTM TEST D638 TYPE V
  7. CAVITY SPEC FOR USE ONLY WITH MOLEX BLADE TERMINAL PART NUMBERS (EXCEPT P/N'S FOR UNSEALED APPLICATIONS) SPECIFIED ELSEWHERE ON THIS DRAWING

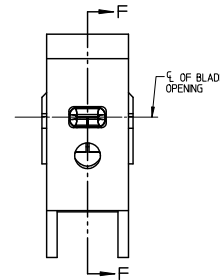
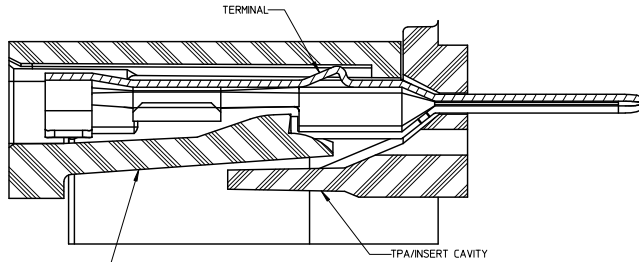
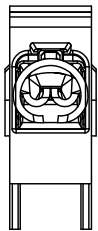

BLADE TERMINAL HOUSING CAVITY SECTION F-F

BLADE CAVITY ASSEMBLY VIEWS

ENTER DESCRIPTION EC NO.: UAU201-0559 DRAWN: HENOS 2011/01/12 CHKD: APPR: BMOSER 2011/01/20 REV:	QUALITY SYMBOLS	GENERAL TOLERANCES (UNLESS SPECIFIED)		DIMENSION STYLE		SCALE	DESIGN UNITS	THIRD ANGLE PROJECTION	
	▽=0	mm	INCH	MM ONLY			METRIC		
	▽=0.1	4 PLACES ±	±	DRAWN BY	DATE	TITLE	MX150 1.5MM BLADE TERMINAL		
	▽=0.3	3 PLACES ±	±	L. PULLIAM	2006/01/31				
	ANGULAR ± 3°	2 PLACES ±	±	CHECKED BY	DATE	MOLEX INCORPORATED			
		1 PLACE ±	±	A. DHIR	2006/02/01	SD-33000-001			
		DRAFT WHERE APPLICABLE MUST REMAIN WITHIN DIMENSIONS		APPROVED BY	DATE	DOCUMENT NO.		SHEET NO.	
				B. MOSER	2006/02/02	SD-33000-001		4 OF 5	
				MATERIAL NO.		THIS DRAWING CONTAINS INFORMATION THAT IS PROPRIETARY TO MOLEX INCORPORATED AND SHOULD NOT BE USED WITHOUT WRITTEN PERMISSION			
				SIZE					

13 12 11 10 9 8 7 6 5 4 3 2 1

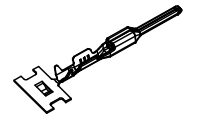

ISO VIEW  
SCALE 2:1

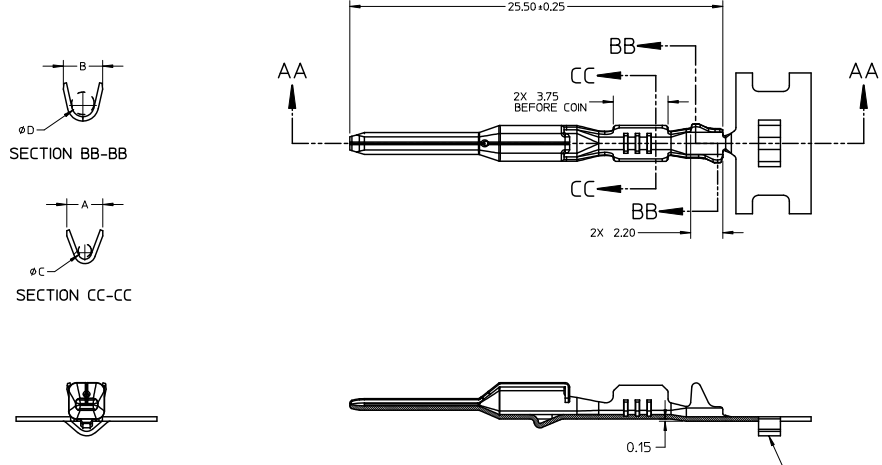

SECTION AA-AA  
P/N'S 33000-0004/1004  
33011-2004/3004  
CARRIER BUMP DIRECTION  
POINTS DOWN FOR TIN PLATED TERMINALS  
POINTS UP FOR PRECIOUS METAL PLATED  
TERMINALS

ENTER DESCRIPTION EC NO. UJ0201-0539 DRAWN: RENO5 2011/01/12 CHKD: APPR: BMOSER 2011/01/20	QUALITY SYMBOLS ∇=0 ∇=0 ∇=0	GENERAL TOLERANCES (UNLESS SPECIFIED)		DIMENSION STYLE MM ONLY		SCALE 5:1	DESIGN UNITS METRIC	THIRD ANGLE PROJECTION		
		4 PLACES ± 0.15	3 PLACES ± 0.25	2 PLACES ± 0.3	1 PLACE ± 0.5	DRAWN BY L. PULLIAM	DATE 2006/01/31	TITLE MX150 1.5MM BLADE TERMINAL		
		ANGULAR ± 3°				CHECKED BY A. DHIR	DATE 2006/02/01	APPROVED BY B. MOSER		
		DRAFT WHERE APPLICABLE MUST REMAIN WITHIN DIMENSIONS				MATERIAL NO. SEE TABLE	DATE 2006/02/02	DOCUMENT NO. SD-33000-001	SHEET NO. 5 OF 5	

12 11 10 9 8 7 6 5 4 3 2 1