

Customer Information Sheet

DRAWING No.: M80-01300XX

SHEET 2 OF 2

IF IN DOUBT - ASK

(C)

NOT TO SCALE

THIRD ANGLE PROJECTION

ALL DIMENSIONS IN mm

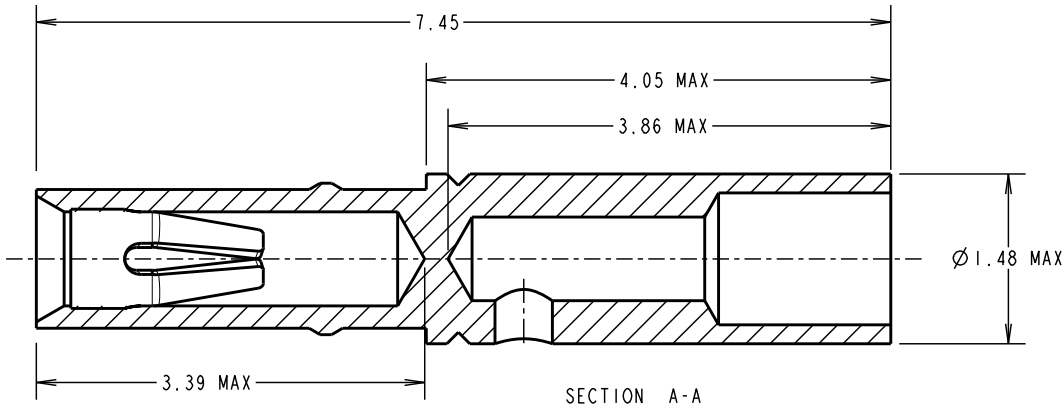

ORDER CODE:
M80-01300XX

FINISH:
01 = 100% TIN SHELL/GOLD CLIP
05 = GOLD SHELL/GOLD CLIP

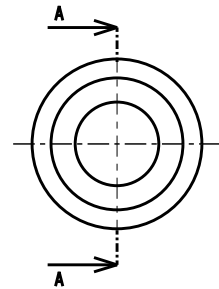

SPECIFICATION:

MATERIAL:
CONTACT SHELL = BRASS
CONTACT CLIP = BERYLLIUM COPPER

FINISH:
01 = 3.5 - 5.0µ 100% TIN OVER NICKEL SHELL, 0.3µ GOLD CLIP
05 = 0.28µ GOLD SHELL, 0.3µ GOLD CLIP

MECHANICAL:
INSERTION FORCE = 2.8N MAX, 1.0N MIN
WITHDRAWAL FORCE = 1.8N MAX, 0.2N MIN
DURABILITY = 500 OPERATIONS

ENVIRONMENTAL:
OPERATING TEMPERATURE = -55°C TO +125°C

PACKING:
BULK
FOR COMPLETE CONNECTOR SPECIFICATION, SEE COMPONENT SPECIFICATION C005XX (LATEST ISSUE)

NOTES:

- SUITABLE FOR WIRE GAUGE 24, 26 & 28 AWG. MAXIMUM INSULATION DIAMETER Ø1.10mm, BS3G210 TYPE A WIRE RECOMMENDED. STRIP WIRE BY 2.00mm FOR CRIMPING.
- RECOMMENDED CRIMP TOOL = M22520/2-01, POSITIONER = T5747,
- FOR INSTRUCTIONS ON HAND CRIMP TOOL M22520/2-01, SEE INSTRUCTION SHEET IS-01.
- RECOMMENDED MATING PIN SIZE = Ø0.51-0.46mm.

SM	17	05.10.10	10965
NAME	ISS.	DATE	C/NOTE
APPROVED: S. MCCULLAGH			
CHECKED: M. G. PLESTED			
DRAWN: I. SANDY			
CUSTOMER REF.:			
ASSEMBLY DRG:			

HARWIN

HARWIN USA TEL: 603 893 5376 FAX: 603 893 5396 mis@harwin.com	HARWIN Europe (UK) TEL: 023 9231 4545 FAX: 023 9231 4590 mis@harwin.co.uk	HARWIN Asia TEL: +65 6 779 4909 FAX: +65 6 779 3868 mis@harwin.com.sg
--	--	--

THIS DRAWING AND ANY INFORMATION OR DESCRIPTIVE MATTER SET OUT HEREON ARE CONFIDENTIAL AND COPYRIGHT PROPERTY OF THE HARWIN GROUP AND MUST NOT BE DISCLOSED, LOANED, COPIED OR USED FOR MANUFACTURING, TENDERING OR FOR ANY OTHER PURPOSE WITHOUT THEIR WRITTEN PERMISSION.

TOLERANCES
X. = ±1mm
X.X = ±0.25mm
X.XX = ±0.10mm
X.XXX = ±0.01mm

ANGLES = ±5°
UNLESS STATED

MATERIAL:
SEE ABOVE

FINISH: SEE ABOVE

S/AREA: mm²

TITLE: CRIMP SOCKET CONTACT ASSEMBLY (SMALL BORE)

DRAWING NUMBER: M80-01300XX

SHT 2 OF 2