

# NH CONNECTOR

Disconnectable Crimp style connectors

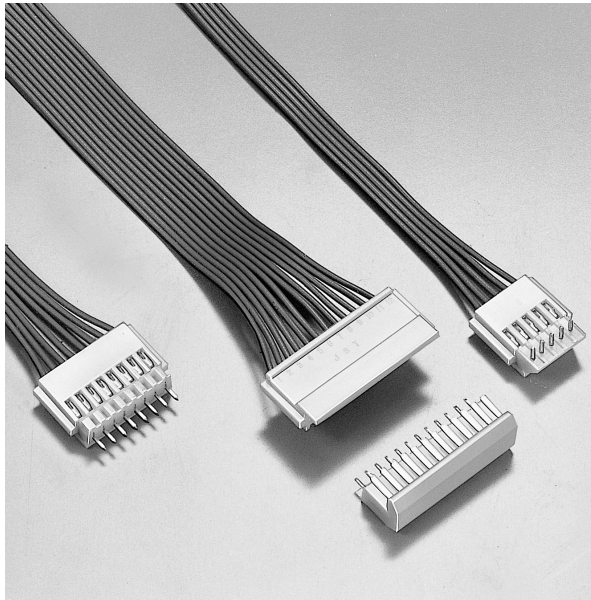

**This 2.5mm pitch connector is used to connect wires to printed circuit boards. The header is available in three configurations: top, side, and bottom entry. This allows the wires to be perpendicular or parallel to the printed circuit board in any direction.**

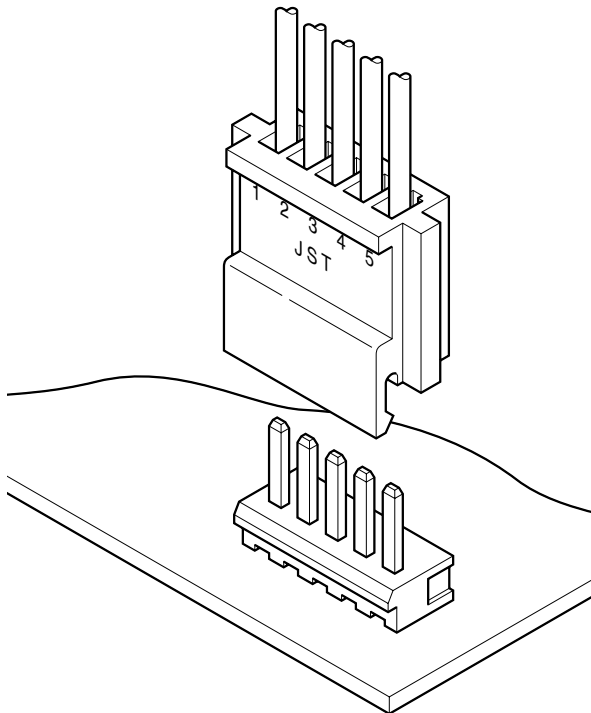

## Features

### • Superior folded beam construction

- (1) This sturdy construction withstands repeated stress, resists permanent deformation, and offers a very long service life.
- (2) High reliability is ensured whether the contact pressure is high or low.
- (3) This contact design has a large tolerance for variations in mating post thickness and resists deformation when pried.

### • Double-sided contact

- (1) The receptacle contact has a protected entry which eliminates contact damage caused by mismatching.
- (2) It provides high contact pressure, is free from abnormal stress, and maintains continuity at all times.
- (3) It has an extremely long service life due to its folded beam design.

### • Wide, sturdy post

The post has a large cross-sectional area to resist prying during insertion into printed circuit boards and mating with connector housings.

### • Molded-in header

The posts are molded into the insulator to provide stability when mounted on printed circuit boards. This also prevents flux from entering the connector during soldering.

## Specifications

- Current rating: 3A AC, DC (AWG #22)
- Voltage rating: 250V AC, DC
- Temperature range: -25°C to +85°C  
(including temperature rise in applying electrical current)
- Contact resistance: Initial value/15m Ω max.  
After environmental testing/20m Ω max.
- Insulation resistance: 500M Ω min.
- Withstanding voltage: 1,500V AC/minute
- Applicable wire: AWG #30 to #22
- Applicable PC board thickness: 1.6mm
- \* Compliant with RoHS.
- \* Refer to "General Instruction and Notice when using Terminals and Connectors" at the end of this catalog.
- \* Contact JST for details.

## Standards

Recognized E60389

Certified LR20812

J50168090

# NH CONNECTOR

## Contact

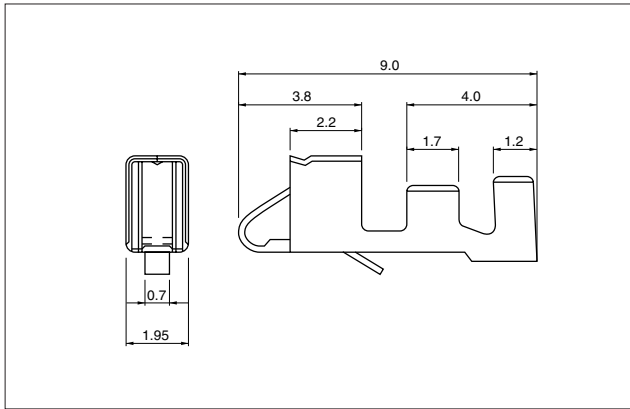

Model No.	Applicable wire			Q'ty / reel
	mm <sup>2</sup>	AWG #	Insulation O.D. (mm)	
<b>SHF-001T-0.8BS</b>	0.08 to 0.33	28 to 22	1.2 to 1.7	5,000
<b>SHF-002T-0.8BS</b>	0.05 to 0.08	30 to 28	0.9 to 1.2	

### Material and Finish

Phosphor bronze, tin-plated (reflow treatment)

### RoHS compliance

Note:

1. Contact JST for gold-plated products.
2. Also contact JST if you require shielded wires, thin wires or other special wires.
3. Contact JST for brass products.

## Housing

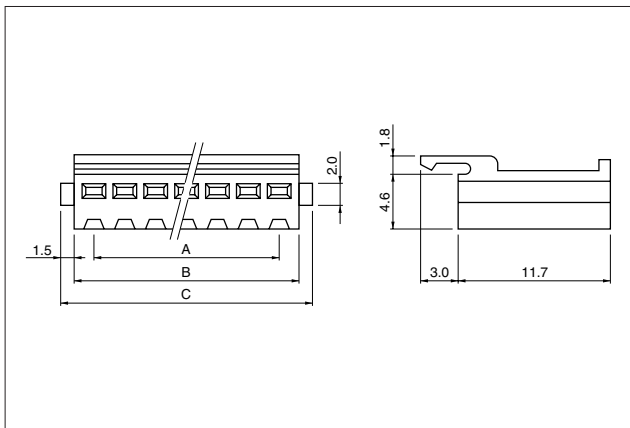

Cir-cuits	Model No.	Dimensions (mm)			Q'ty / bag
		A	B	C	
2	<b>H 2P-SHF-AA</b>	2.5	5.7	8.7	1,000
3	<b>H 3P-SHF-AA</b>	5.0	8.2	11.2	1,000
4	<b>H 4P-SHF-AA</b>	7.5	10.7	13.7	1,000
5	<b>H 5P-SHF-AA</b>	10.0	13.2	16.2	1,000
6	<b>H 6P-SHF-AA</b>	12.5	15.7	18.7	1,000
7	<b>H 7P-SHF-AA</b>	15.0	18.2	21.2	500
8	<b>H 8P-SHF-AA</b>	17.5	20.7	23.7	500
9	<b>H 9P-SHF-AA</b>	20.0	23.2	26.2	500
10	<b>H10P-SHF-AA</b>	22.5	25.7	28.7	500
11	<b>H11P-SHF-AA</b>	25.0	28.2	31.2	500
12	<b>H12P-SHF-AA</b>	27.5	30.7	33.7	500
13	<b>H13P-SHF-AA</b>	30.0	33.2	36.2	500
14	<b>H14P-SHF-AA</b>	32.5	35.7	38.7	500
15	<b>H15P-SHF-AA</b>	35.0	38.2	41.2	200
16	<b>H16P-SHF-AA</b>	37.5	40.7	43.7	200
18	<b>H18P-SHF-AA</b>	42.5	45.7	48.7	200
20	<b>H20P-SHF-AA</b>	47.5	50.7	53.7	200
21	<b>H21P-SHF-AA</b>	50.0	53.2	56.2	200
22	<b>H22P-SHF-AA</b>	52.5	55.7	58.7	200
24	<b>H24P-SHF-AA</b>	57.5	60.7	63.7	200
25	<b>H25P-SHF-AA</b>	60.0	63.2	66.2	200

### Material

PA 6, UL94V-0, natural (white)

### RoHS compliance

<For reference> As the color identification, the following alphabet shall be put in the underlined part.  
For availability, delivery and minimum order quantity, contact JST.

ex. **H2P-SHF-AA-oo**  
(blank)...natural (white)  
K...black R...red TR...tomato red E...blue M...green  
O...orange N...brown

## Header

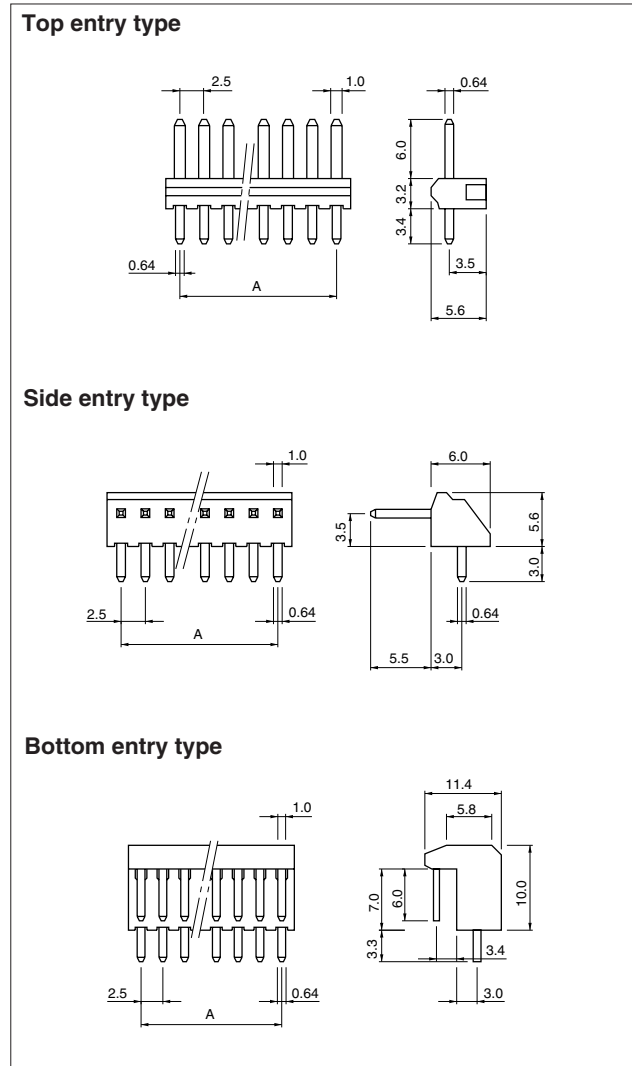

Circuits	Model No.			Dimensions A (mm)	Q'ty / box		
	Top entry type	Side entry type	Bottom entry type		Top entry type	Side entry type	Bottom entry type
2	B 2P-SHF-1AA	BS 2P-SHF-1AA	BE 2P-SHF-1AA	2.5	1,000	1,000	250
3	B 3P-SHF-1AA	BS 3P-SHF-1AA	BE 3P-SHF-1AA	5.0	1,000	1,000	250
4	B 4P-SHF-1AA	BS 4P-SHF-1AA	BE 4P-SHF-1AA	7.5	1,000	500	250
5	B 5P-SHF-1AA	BS 5P-SHF-1AA	BE 5P-SHF-1AA	10.0	1,000	500	250
6	B 6P-SHF-1AA	BS 6P-SHF-1AA	BE 6P-SHF-1AA	12.5	500	500	150
7	B 7P-SHF-1AA	BS 7P-SHF-1AA	BE 7P-SHF-1AA	15.0	500	500	150
8	B 8P-SHF-1AA	BS 8P-SHF-1AA	BE 8P-SHF-1AA	17.5	500	500	150
9	B 9P-SHF-1AA	BS 9P-SHF-1AA	BE 9P-SHF-1AA	20.0	500	500	150
10	B10P-SHF-1AA	BS10P-SHF-1AA	BE10P-SHF-1AA	22.5	250	250	100
11	B11P-SHF-1AA	BS11P-SHF-1AA	BE11P-SHF-1AA	25.0	250	250	100
12	B12P-SHF-1AA	BS12P-SHF-1AA	BE12P-SHF-1AA	27.5	250	200	100
13	B13P-SHF-1AA	BS13P-SHF-1AA	BE13P-SHF-1AA	30.0	250	200	100
14	B14P-SHF-1AA	BS14P-SHF-1AA	BE14P-SHF-1AA	32.5	250	200	50
15	B15P-SHF-1AA	BS15P-SHF-1AA	BE15P-SHF-1AA	35.0	250	200	50
16	B16P-SHF-1AA	BS16P-SHF-1AA	—	37.5	250	200	—
17	B17P-SHF-1AA	—	—	40.0	200	—	—
18	B18P-SHF-1AA	BS18P-SHF-1AA	—	42.5	200	200	—
19	B19P-SHF-1AA	—	—	45.0	250	—	—
20	B20P-SHF-1AA	BS20P-SHF-1AA	—	47.5	250	200	—
21	B21P-SHF-1AA	BS21P-SHF-1AA	—	50.0	250	200	—
22	B22P-SHF-1AA	BS22P-SHF-1AA	—	52.5	250	200	—
23	B23P-SHF-1AA	—	—	55.0	250	—	—
24	B24P-SHF-1AA	BS24P-SHF-1AA	—	57.5	250	200	—
25	B25P-SHF-1AA	BS25P-SHF-1AA	—	60.0	250	200	—

### Material and Finish

Post: Brass, copper-undercoated, tin-plated (reflow treatment)  
 Wafer: PA 66, UL94V-0, natural (white) for the top and side entry types  
 PA 6, UL94V-0, natural (white) for the bottom entry type

**RoHS compliance** This product displays (LF)(SN) on a label.

<For reference> As the color identification, the following alphabet shall be put in the underlined part.  
 For availability, delivery and minimum order quantity, contact JST.

ex. **B2P-SHF-1AA-oo**

(blank)...natural (white)

BK...black R...red TR...tomato red E...blue M...green

O...orange N...brown

# NH CONNECTOR

## PC board layout (viewed from soldering side) and Assembly layout

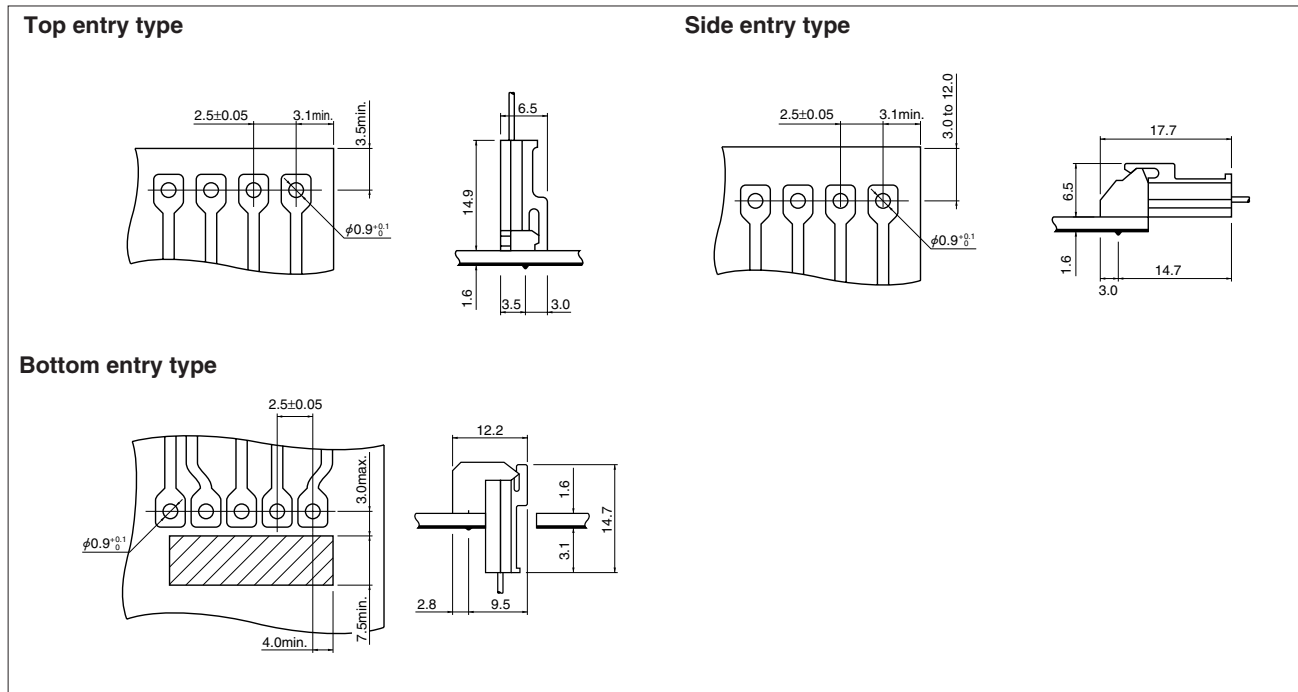

**Note:**

1. Tolerances are non-cumulative:  $\pm 0.05\text{mm}$  for all centers.
2. Hole dimensions differ according to the kind of PC board and piercing method. The dimensions above should serve as a guideline.  
Contact JST for details.

## Crimping machine, Applicator

Contact	Crimping machine	Crimp applicator	Dies	Crimp applicator with dies
SHF-001T-0.8BS	AP-K2N	MKS-LS, MKS-L	MK/SHF-001-08S	APLMK SHF001-08S
		*MKS-SC	SC/SHF-001-08S	APLSC SHF001-08S
SHF-002T-0.8BS	AP-K2N	MKS-LS, MKS-L	MK/SHF-002-08S	APLMK SHF002-08S
		*MKS-SC	SC/SHF-002-08S	APLSC SHF002-08S

Note: \*Strip-crimp applicator