

13 12 11 10 9 8 7 6 5 4 3 2 1

NOTES:

1. MATERIAL:
CDA 510 PHOS. BRONZE .0080±.0004/(0.203±0.010) THICK.
2. FINISH:
 *2 = SELECTIVE GOLD PLATE .000030/(0.00076) MIN., AND SELECTIVE MATTE TIN .000100/(0.00254) OVER .000050/(0.00127) MIN. NICKEL OVERALL.
 *3 = SELECTIVE GOLD PLATE .000015/(0.00038) MIN., AND SELECTIVE MATTE TIN .000080/(0.00203) OVER .000050/(0.00127) MIN. NICKEL OVERALL.
 *4 = SELECTIVE GOLD PLATE .000050/(0.00127) MIN., AND SELECTIVE MATTE TIN .000100/(0.00254) OVER .000050/(0.00127) MIN. NICKEL OVERALL.
 *THE PRIMARY SHIPPING CARTON WILL BE LABELED 'COMPLIANT TO RoHS DIRECTIVE 2002/95/EC AND ELV ANNEX II OF DIRECTIVE 2000/53/EC.' CARTONS WITHOUT THIS LABEL MAY CONTAIN PRODUCT WITH TIN-LEAD PLATING.
3. PRODUCT SPECIFICATION: SEE PSX-44485-0001.
4. PACKAGING SPECIFICATION: PK-44485-001 FOR CHAIN TERMINALS
PK-5556-003 FOR LOOSE TERMINALS
5. MATES WITH 5558, 5566 AND 5569 SERIES CONNECTORS.
6. TERMINAL FOR USE WITH 5557 SERIES HOUSINGS.

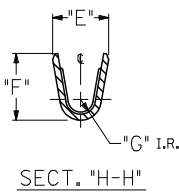
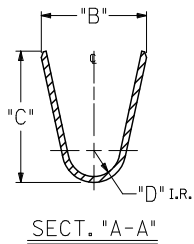
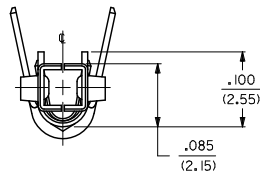
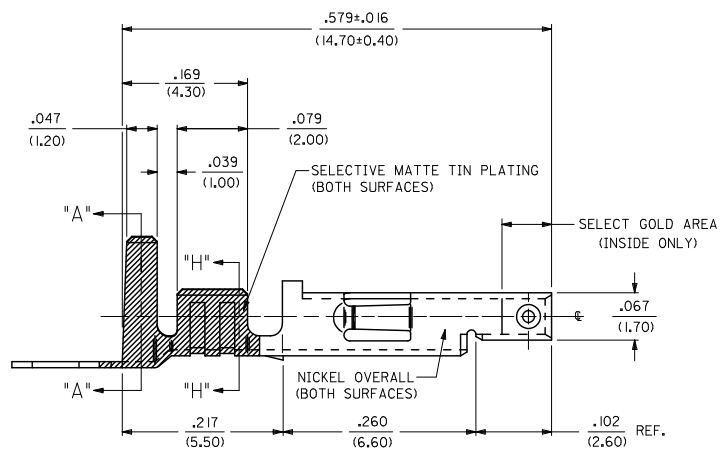
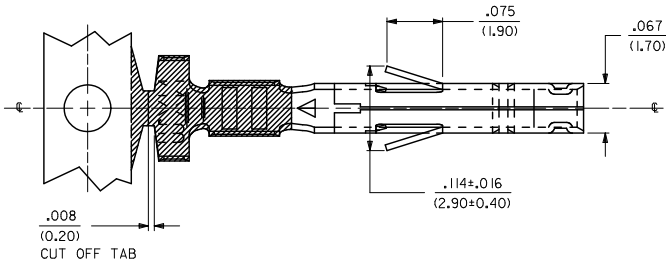

ADDED PKG. NOTE. EC NO: UCP200-0471 DRAWN: JAGUILAR 2009/12/23 CHKD: BELL 2009/12/23 APPR: SMITH 2009/12/28	QUALITY SYMBOLS ▽=0 ▽=0	GENERAL TOLERANCES (UNLESS SPECIFIED)		DIMENSION STYLE IN/MM		SCALE 10:1	DESIGN UNITS METRIC	THIRD ANGLE PROJECTION	
		4 PLACES ±.005 ±.005	mm	INCH	DRAWN BY GEP	DATE 08/08/94	TITLE HIGH CYCL'G TERM FEM CRIMP, MINI-FIT JR. BLANK-PLATE-FORM		
		3 PLACES ±.010 ±.010	±.010	±.010	CHECKED BY RJF	DATE 08/08/94	MOLEX INCORPORATED		
		2 PLACES ±0.25 ±.014	±0.25	±.014	APPROVED BY RJF	DATE 08/08/94	MATERIAL NO. SD-44485-*** DOCUMENT NO.		
ANGULAR ±1/2°		DRAFT WHERE APPLICABLE MUST REMAIN WITHIN DIMENSIONS		SEE CHART		SHEET NO. 1 OF 2		THIS DRAWING CONTAINS INFORMATION THAT IS PROPRIETARY TO MOLEX INCORPORATED AND SHOULD NOT BE USED WITHOUT WRITTEN PERMISSION	

12 11 10 9 8 7 6 5 4 3 2 1

ITEM NO.	WIRE GAGE	DIM. "B"	DIM. "C"	DIM. "D"	DIM. "E"	DIM. "F"	DIM. "G"
44485-1211	18-24 GA.	.142±.012	.177±.016	.035	.075±.012	.091±.016	.020
44485-1212		(3.60±0.30)	(4.50±0.40)	(0.90)	(1.90±0.30)	(2.30±0.40)	(0.50)
44485-2211	22-28 GA.	.091±.012	.091±.016	.024	.071±.012	.065±.016	.016
44485-2212		(2.30±0.30)	(2.30±0.40)	(0.60)	(1.80±0.30)	(1.65±0.40)	(0.40)
44485-3211	16 GA.	.142±.012	.177±.016	.035	.091±.012	.106±.016	.024
44485-3212		(3.60±0.30)	(4.50±0.40)	(0.90)	(2.30±0.30)	(2.70±0.40)	(0.60)
44485-5211	28-30 GA.	.091±.012	.091±.016	.024	.050±.010	.044±.010	.010
44485-5212		(2.30±0.30)	(2.30±0.40)	(.60)	(1.27±0.25)	(1.12±0.25)	(0.25)
44485-1311	18-24 GA.	.142±.012	.177±.016	.035	.075±.012	.091±.016	.020
44485-1312		(3.60±0.30)	(4.50±0.40)	(0.90)	(1.90±0.30)	(2.30±0.40)	(0.50)
44485-2311	22-28 GA.	.091±.012	.091±.016	.024	.071±.012	.065±.016	.016
44485-2312		(2.30±0.30)	(2.30±0.40)	(0.60)	(1.80±0.30)	(1.65±0.40)	(0.40)
44485-3311	16 GA.	.142±.012	.177±.016	.035	.091±.012	.106±.016	.024
44485-3312		(3.60±0.30)	(4.50±0.40)	(0.90)	(2.30±0.30)	(2.70±0.40)	(0.60)
44485-5311	28-30 GA.	.091±.012	.091±.016	.024	.050±.010	.044±.010	.010
44485-5312		(2.30±0.30)	(2.30±0.40)	(.60)	(1.27±0.25)	(1.12±0.25)	(0.25)
44485-1411	18-24 GA.	.142±.012	.177±.016	.035	.075±.012	.091±.016	.020
44485-1412		(3.60±0.30)	(4.50±0.40)	(0.90)	(1.90±0.30)	(2.30±0.40)	(0.50)
44485-2411	22-28 GA.	.091±.012	.091±.016	.024	.071±.012	.065±.016	.016
44485-2412		(2.30±0.30)	(2.30±0.40)	(0.60)	(1.80±0.30)	(1.65±0.40)	(0.40)
44485-3411	16 GA.	.142±.012	.177±.016	.035	.091±.012	.106±.016	.024
44485-3412		(3.60±0.30)	(4.50±0.40)	(0.90)	(2.30±0.30)	(2.70±0.40)	(0.60)
44485-5411	28-30 GA.	.091±.012	.091±.016	.024	.050±.010	.044±.010	.010
44485-5412		(2.30±0.30)	(2.30±0.40)	(.60)	(1.27±0.25)	(1.12±0.25)	(0.25)

LEGEND:

44485 - * * * | *

BASE NO. _____

CRIMP SIZE _____

*1' = 18-24

*2' = 22-28

*3' = 16

*5' = 28-30

PLATING (SEE NOTE #2)

*2' .000030/0.00076 GOLD

*3' .000015/0.00038 GOLD

*4' .000050/0.00127 GOLD

CHAIN OR LOOSE _____

*1' = CHAIN

*2' = LOOSE

SEE SHEET ONE EC NO: UCP2010-0471 DRAWN: JAGUILAR 2009/12/23 CHKD: BELL 2009/12/23 APPR: SMITH 2009/12/28	QUALITY SYMBOLS	GENERAL TOLERANCES (UNLESS SPECIFIED)		DIMENSION STYLE IN/MM		SCALE ---	DESIGN UNITS INCH	THIRD ANGLE PROJECTION
	▽=0	4 PLACES	mm	INCH	DRAWN BY GEP	DATE 08/08/94	TITLE HIGH CYCL'G TERM FEM CRIMP, MINI-FIT JR. BLANK-PLATE-FORM	
	▽=0	3 PLACES	±---	±---	CHECKED BY RJF	DATE 08/08/94	MOLEX INCORPORATED	
		2 PLACES	±---	±---	APPROVED BY RJF	DATE 08/08/94	MATERIAL NO. SEE CHART	DOCUMENT NO. SD-44485-****
	1 PLACE	±---	±---	ANGULAR ±1/2°		THIS DRAWING CONTAINS INFORMATION THAT IS PROPRIETARY TO MOLEX INCORPORATED AND SHOULD NOT BE USED WITHOUT WRITTEN PERMISSION		

13	12	11	10	9	8	7	6	5	4	3	2	1
----	----	----	----	---	---	---	---	---	---	---	---	---

lb_frame_C.P.M.E.T
Rev. D. 2004/04/02