

NOTES:

1. TERMINAL TO BE USED IN HOUSINGS 70066-**** AND 70450-****
2. REFER TO PRODUCT SPECIFICATION PS-71851
3. REFER TO MOLEX OPERATIONS AND SERVICE MANUAL FOR CRIMP DETAILS
4. TERMINAL TO BE USED WITH (0.64)/.025 SQUARE PINS
5. TERMINAL TO BE USED WITH 22-24 AWG STRANDED WIRE WITH (1.63)/.064 MAX. DIA. INSULATION
6. TERMINALS SUPPLIED LOOSE PER DRAWING PK-70873-0822

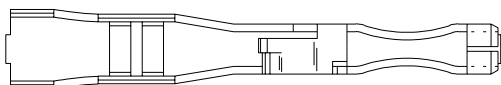

PLATING:

.000015 MINIMUM GOLD PLATE IN SELECT AREA WITH .000075 MINIMUM TIN PLATE IN SELECT AREA OVER NICKEL PLATE OVERALL
 *THE PRIMARY SHIPPING CARTON WILL BE LABELED "COMPLIANT TO RoHS DIRECTIVE 2002/95/EC AND ELV ANNEX II OF DIRECTIVE 2000/53/EC". CARTONS WITHOUT THIS LABEL MAY CONTAIN PRODUCT WITH LEAD.

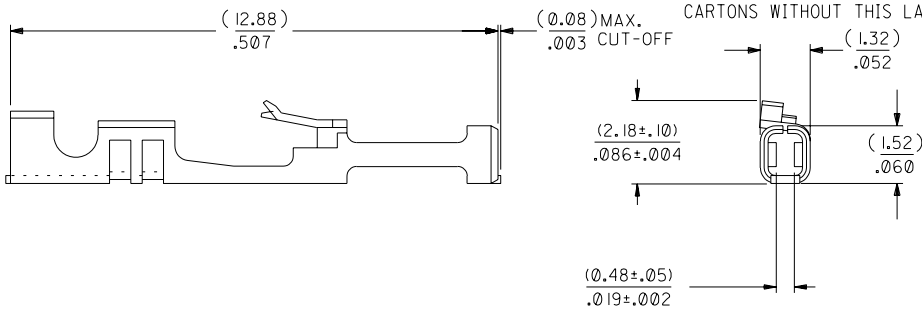

DIMENSIONS SHOWN (METRIC) INCH UNLESS OTHERWISE SPECIFIED TOLERANCES: ANGULAR ± 1/2°

	INCH	METRIC
3 PLACE	± .010	---
2 PLACE	± .014	± 0.25
1 PLACE	---	± 0.35

DRAFT WHERE APPLICABLE MUST REMAIN WITHIN DIMENSIONS

DRWG. BY: RWHITE CHK'D. BY: DMORGAN
 APP'D. BY: SMILLER SCALE: 10: 1

REVISIONS: 0 = 0 REVISE ONLY ON CAD SYSTEM

TITLE: TERMINAL-BOX/CRIMP HIGH FORCE CONTACT

MOLEX INCORPORATED SHEET NO. 1 DATE 04/06/21
 LISLE, ILL. 60532 U.S.A.

PART NO. 016-02-1125 DRWG. NO. SD-71851-0224

THIS DRAWING CONTAINS INFORMATION THAT IS PROPRIETARY TO MOLEX INC. AND SHOULD NOT BE USED WITHOUT WRITTEN PERMISSION. DIV. DA SIZE B

LTR.	REVISIONS	LTR.	REVISIONS
		A	INITIAL RELEASE UCP2004-2560 RWHITE 04/06/21