

20 19 18 17 16 15 14 13 12 11 10 9 8 7 6 5 4 3 2 1

7879-1(***)*		7879-2(***)*	
PART NO.	ENG. NO.	PART NO.	ENG. NO.
08-55-0124	7879-1P208	50-29-1744	7879-2P228
08-55-0129	7879-1P208L	50-29-1745	7879-2P228L
08-50-0004	7879-1P102		
08-50-0005	7879-1P102L		
50-29-1900	7879-1P154		
46999-0101	7879-1P154L		

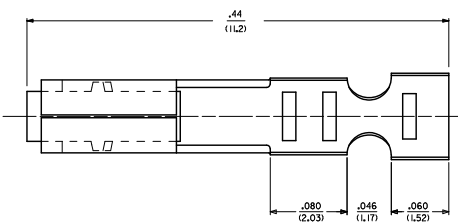
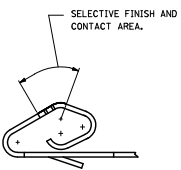

LEGEND:

7879-1(***)*
 MATERIAL .008/ (0.20) THICK
 1 - BRASS
 2 - PHOS. BRONZE
 FORM BLANK - REEL, PER WINDING DETAIL B
 L - LOOSE, PER PK-2759-001
 PLATING

NOTES:
 1. MATERIAL: SEE LEGEND.
 2. FINISH: SEE LEGEND.
 3. THIS PART CONFORMS TO PRODUCT SPEC. 7879.
 4. PACKAGING SPECIFICATION: SEE LEGEND.
 5. CRIMP FOR 24-30 AWG. WIRE WITH .060(1.52) MAX. INSULATION DIA.
 6. THIS TERMINAL TO BE USED IN 7880 HOUSING.
 7. DIMENSIONS GIVEN ACROSS CENTERLINES ARE SYMMETRICAL ABOUT THOSE CENTERLINES WITHIN HALF THE TOTAL TOLERANCE.
 8. CRIMP WILL ACCEPT 22 AWG. WIRE WITH .062(1.57) MAX. INSULATION DIA.
 9. THIS PART CONFORMS TO CLASS B REQUIREMENTS OF COSMETIC SPECIFICATION PS-45499-002.

(102) OVERALL TIN: .000200(0.00508) MIN. OVER .000100(0.00254) MIN. COPPER
 (P154) OVERALL TIN: .000100(0.00254) MIN. OVERALL NICKEL UNDERPLATE: .00050(0.00127) MIN.
 (208) SELECT GOLD: .000015(0.00038) MIN.
 SELECT TIN: .000100(0.00254) MIN.
 OVERALL NICKEL UNDERPLATE: .000050(0.00127) MIN.
 (228) SELECT GOLD: .000030(0.00076) MIN.
 SELECT TIN: .000100(0.00254) MIN.
 OVERALL NICKEL UNDERPLATE: .000050(0.00127) MIN.

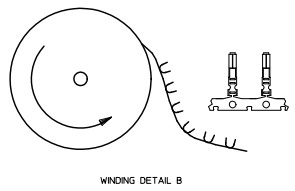
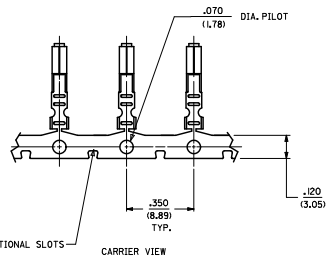
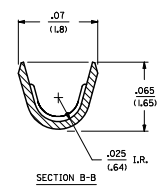
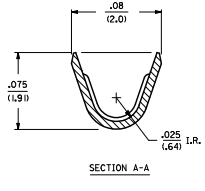
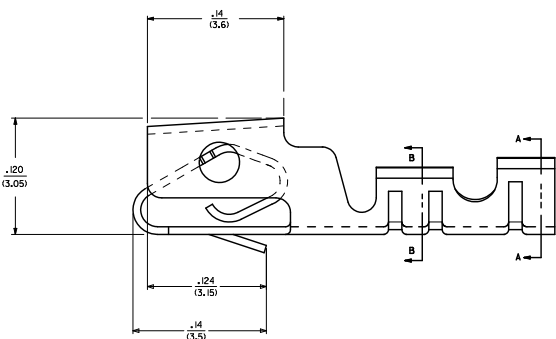
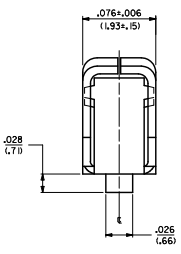

ADD: 46999-0101 FILED: 02/22/18 ENGINEER: JEFFREY CHECKER: JEFFREY APPROVAL: JEFFREY	QUALITY SYMBOLS	GENERAL TOLERANCES (UNLESS SPECIFIED)	DIMENSION STYLE	SCALE	DESIGN UNITS	THIRD ANGLE PROJECTION	
	$\nabla=0$ $\nabla=0$ $\nabla=0$	4 PLACES ±--- ±--- 3 PLACES ±--- ±.010 2 PLACES ±0.25 ±.014 1 PLACE ±0.36 ±--- ANGULAR ±1/2°	IN/MM INCH	DRAWN BY: GJZIK CHECKED BY: DATE: 12/22/18 APPROVED BY: DATE: 12/22/18 LENZ	(2.54)/100 KK, CRIMP TYPE SHROUDED TERMINAL	INCH	
	DRAFT WHERE APPLICABLE MUST REMAIN WITHIN DIMENSIONS	SEE CHART	MATERIAL NO.	DOCUMENT NO.	MOLEX INCORPORATED		SHEET NO. 1 OF 1
					SD-7879		

19 18 17 16 15 14 13 12 11 10 9 8 7 6 5 4 3 2 1