

NOTES:

1. TERMINAL TO BE USED IN HOUSINGS 70066-**** AND 70450-****
2. REFER TO PRODUCT SPECIFICATION PS-71851
3. REFER TO MOLEX OPERATIONS AND SERVICE MANUAL FOR CRIMP DETAILS
4. TERMINAL TO BE USED WITH (0.64)/.025 SQUARE PINS
5. TERMINAL TO BE USED WITH 24-30 AWG STRANDED WIRE WITH (1.52)/.060 MAX. DIA. INSULATION
6. TERMINALS SUPPLIED IN REEL FORM

PLATING:

.000150 MINIMUM TIN PLATE
OVER NICKEL PLATE.

*THE PRIMARY SHIPPING CARTON WILL BE LABELED "COMPLIANT TO RoHS DIRECTIVE 2002/95/EC AND ELV ANNEX II OF DIRECTIVE 2000/53/EC". CARTONS WITHOUT THIS LABEL MAY CONTAIN PRODUCT WITH LEAD.

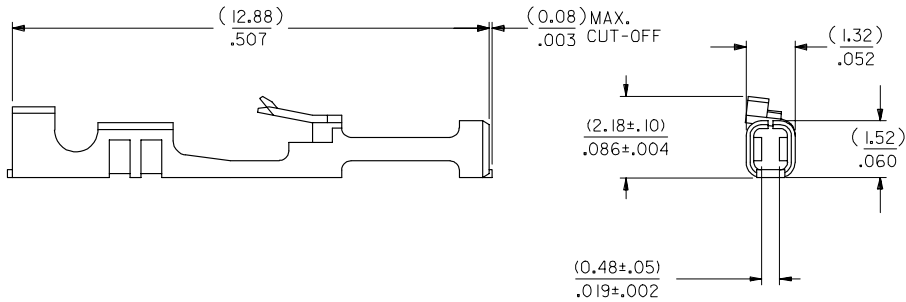
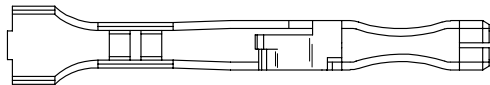

INITIAL RELEASE EC NO: UCP2005-1611 DRAWN BY: MSIBARRA 2005/04/04 CHECKED BY: DMORGAN 2005/04/04 APPROVED BY: SMILLER 2005/04/08 REV A	QUALITY SYMBOLS ▽=0 ∇=0	GENERAL TOLERANCES (UNLESS SPECIFIED) <table border="1"> <thead> <tr> <th></th> <th>mm</th> <th>INCH</th> </tr> </thead> <tbody> <tr> <td>4 PLACES</td> <td>± .---</td> <td>± .---</td> </tr> <tr> <td>3 PLACES</td> <td>± .---</td> <td>± .010</td> </tr> <tr> <td>2 PLACES</td> <td>± 0.25</td> <td>± .014</td> </tr> <tr> <td>1 PLACE</td> <td>± 0.35</td> <td>± .---</td> </tr> </tbody> </table> ANGULAR ±1/2°		mm	INCH	4 PLACES	± .---	± .---	3 PLACES	± .---	± .010	2 PLACES	± 0.25	± .014	1 PLACE	± 0.35	± .---	DIMENSION STYLE IN/MM	SCALE 10:1	DESIGN UNITS INCH	THIRD ANGLE PROJECTION
		mm	INCH																		
	4 PLACES	± .---	± .---																		
	3 PLACES	± .---	± .010																		
2 PLACES	± 0.25	± .014																			
1 PLACE	± 0.35	± .---																			
		DRAWN BY: MSIBARRA 05/02/02 CHECKED BY: DMORGAN 05/02/02 APPROVED BY: SMILLER 05/02/02	DATE: 05/02/02 DATE: 05/02/02 DATE: 05/02/02	TITLE TERMINAL-BOX/CRIMP HIGH FORCE CONTACT																	
		DRAFT WHERE APPLICABLE MUST REMAIN WITHIN DIMENSIONS	MATERIAL NO. 016-02-1112	DOCUMENT NO. SD-71851-0004	MOLEX INCORPORATED	SHEET NO. 1 OF 1															
			SIZE B	THIS DRAWING CONTAINS INFORMATION THAT IS PROPRIETARY TO MOLEX INCORPORATED AND SHOULD NOT BE USED WITHOUT WRITTEN PERMISSION																	