

20 19 18 17 16 15 14 13 12 11 10 9 8 7 6 5 4 3 2 1

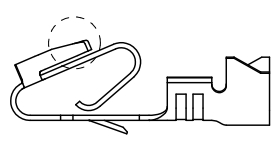

ALTERNATE GEOMETRY
SEE NOTE 10

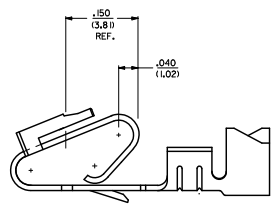

SELECTIVE PLATING
LOCATION

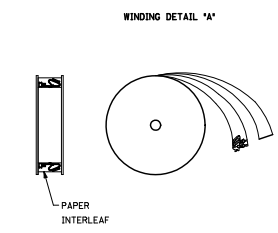

WINDING DETAIL "A"

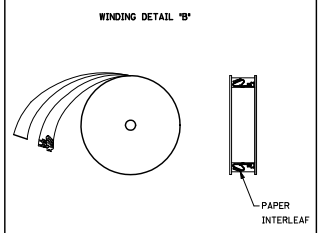

WINDING DETAIL "B"

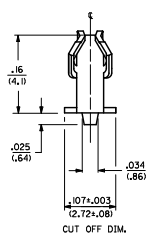
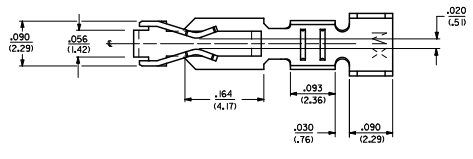

CUT OFF DIM.

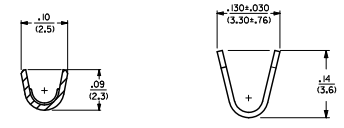
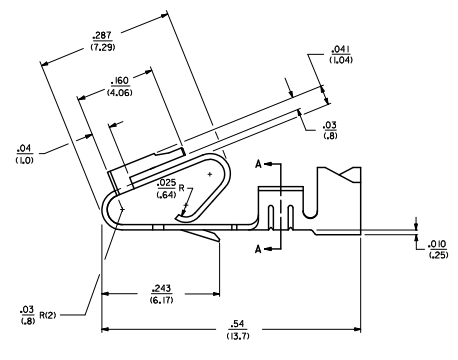

SECTION A-A

LEGEND: 6838- ()
 MATERIAL: L271/0106 THK
 BLANK=BRASS
 A=PHOS BRONZE
 WINDING
 A= PER DETAIL A
 BLANK= PER DETAIL B
 FORM
 BLANK= CHAIN
 L= LOOSE
 PLATING
 SEE NOTE 2

- NOTES:
 1. MATERIAL: SEE LEGEND
 2. FINISH:
 909 - OVERALL HOT TIN DIP: .000100(0.00254) MIN.
 102 - OVERALL TIN: .000200(0.00508) MIN.
 OVERALL COPPER: .000100(0.00254) MIN.
 132 - OVERALL TIN: .000200(0.00508) MIN.
 OVERALL COPPER: .000200(0.00508) MIN.
 503 - OVERALL HARD GOLD: .00030(0.00076) MIN.
 OVERALL NICKEL: .000050(0.00127) MIN.
 550 - SELECT HARD GOLD: .00015(0.00381) MIN.
 OVERALL NICKEL: .00030(0.00076) MIN.
 OVERALL HARD GOLD FLASH: .000002(0.00005) MIN.
 555 - SELECT HARD GOLD: .00015(0.00381) MIN.
 OVERALL NICKEL: .00030(0.00076) MIN.
 558 - SELECT HARD GOLD: .00030(0.00076) MIN.
 OVERALL HARD GOLD FLASH: .000002(0.00005) MIN.
 OVERALL NICKEL: .00050(0.0127) MIN.
 561 - SELECT HARD GOLD: .00030(0.00076) MIN.
 OVERALL NICKEL: .00050(0.0127) MIN.
 3. PRODUCT SPECIFICATION: PS-40-02
 4. PACKAGING SPECIFICATION: CHAIN FORM SEE PK-6838-001
 LOOSE FORM SEE PK-2759-001
 5. TERMINAL FOR USE IN HOUSING SERIES 6442 AND 4995.
 6. SEE 7258 SERIES FOR THIS PART WITH CRIMP FOR 22-26 AWG WIRE.
 7. CRIMP FOR 18 TO 20 GA. WIRE WITH MAX. INSULATION DIA. OF .100(2.79).
 STRIP LENGTH OF .125(3.18) / (3.18(2.54))
 8. DIMENSIONS GIVEN ACROSS CENTERLINES ARE SYMMETRICAL ABOUT THOSE CENTERLINES WITHIN HALF THE TOTAL TOLERANCE.
 9. THIS PART CONFORMS TO CLASS B REQUIREMENTS OF COSMETIC SPECIFICATION PS-45499-002.
 10. ALTERNATE GEOMETRY PRESENT ON SOME PART NUMBERS. SEE SHEET 2.

ADD. ALT. GEOMETRY ERS: 11/15/89 CHROMKOPFER 2011/09/14 CHYKOSOUSEK 2011/02/23 APPROV: SMTH 2011/02/23 REV	QUALITY SYMBOLS	GENERAL TOLERANCES (UNLESS SPECIFIED)	DIMENSION STYLE	SCALE	DESIGN UNITS	THIRD ANGLE PROJECTION	
	4 PLACES ± --- ± --- 3 PLACES ± --- ± --- 2 PLACES ± 0.25 ± 0.15 1 PLACE ± 0.36 ± --- ANGULAR ± 1/2°	MIN INCH ± --- ± --- ± 0.10 ± 0.15 ± --- ± ---	IN/MM 11/15/89 11/15/89	QUZIK PATEL LENZ	DATE DATE DATE	INCH INCH	TRIFURCON TERMINAL CRIMP TYPE, .156 CENTERS 18 TO 20 AWG WIRE MOLEX INCORPORATED
	DRAFT WHERE APPLICABLE MUST REMAIN WITHIN DIMENSIONS	SEE CHART	PAPER NO. SD-6838	DOCUMENT NO.	SHEET NO.	1 OF 2	
	THIS DRAWING CONTAINS INFORMATION THAT IS PROPRIETARY TO MOLEX INCORPORATED AND SHOULD NOT BE USED WITHOUT WRITTEN PERMISSION						

6838-(*)**			6838-A(*)**		
PART NO.	ENG. NO.		PART NO.	ENG. NO.	
08-50-0187	6838-(P909)	SEE NOTE 1	08-58-0187	6838-A(P558)	
08-50-0189	6838-(P909)L	SEE NOTE 1	08-58-0189	6838-A(P558)L	
08-50-0275	6838-(P909)-A		08-60-0001	6838-A(132)	
08-50-0026	6838-(P102)		08-60-0002	6838-A(132)L	
	6838-(P102)L		08-58-0102	6838-A(558)	
08-50-0028	6838-(102)			6838-A(558)L	
08-50-0029	6838-(102)L		08-58-0108	6838-A(503)	
			08-58-0109	6838-A(503)L	
			08-52-0112	6838-A(P909)	SEE NOTE 1
			08-52-0113	6838-A(P909)L	SEE NOTE 1
			08-50-0024	6838-A(102)	
			08-50-0251	6838-A(102)L	
			08-58-0105	6838-A(P555)	
			08-58-0106	6838-A(P555)L	
			08-58-0110	6838-A(P561)	SEE NOTE 1
			08-58-0111	6838-A(P561)L	SEE NOTE 1
			08-58-0118	6838-A(561)	
			08-58-0119	6838-A(561)L	
			08-58-0131	6838-A(550)	
			08-58-0132	6838-A(550)L	

NOTES:
 1. PART MANUFACTURED WITH ALTERNATE GEOMETRY. SEE SHEET 1.

ADD. ALT. GEOMETRY ENG. NO. 11/15/89 DRAWN BY GUZIK CHECKED BY PATEL APPROVED BY LENZ DATE 11/15/89	QUALITY SYMBOLS	GENERAL TOLERANCES (UNLESS SPECIFIED)	DIMENSION STYLE	SCALE	DESIGN UNITS	THIRD ANGLE PROJECTION
	▽=0	4 PLACES ±--- INCH	IN/MM	---	INCH	
	▽=0	3 PLACES ±--- INCH				
		2 PLACES ±--- INCH				
	1 PLACE ±--- INCH	ANGULAR ±1/2°				
		DRAFT WHERE APPLICABLE MUST REMAIN WITHIN DIMENSIONS				
		MATERIAL NO. SEE CHART				
		DOCUMENT NO. SD-6838				
		THIS DRAWING CONTAINS INFORMATION THAT IS PROPRIETARY TO MOLEX INCORPORATED AND SHOULD NOT BE USED WITHOUT WRITTEN PERMISSION				
						SHEET NO. 2 OF 2

