

13 12 11 10 9 8 7 6 5 4 3 2 1

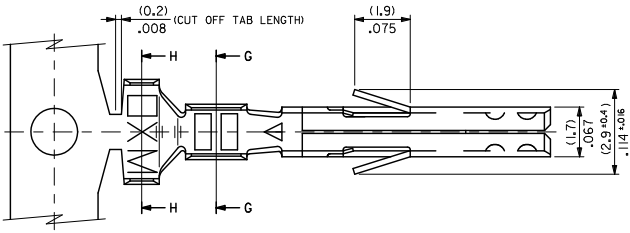

NOTES

1. MATERIAL: SEE CHART.
2. FINISH: SEE CHART.
3. PRODUCT SPECIFICATION: PS-5556-001, PS-5556-002, PS-5556-003.
4. PACKAGING SPECIFICATION: PK-5556-001 FOR CHAIN TERMINALS, PK-5556-003 FOR LOOSE TERMINALS.
5. MATES WITH: 5558, 5566, 5569, 30069, 30070, 42440, 42404, 43879, 43810, 44068.
6. APPLICABLE HOUSING: 5557, 30067, 44516, OR 42474.
7. THE NUMBER OF SERRATIONS TO BE ONE FOR WIRE RANGE #22-28.
8. WHEN TERMINALS ARE INSTALLED IN THE HOUSING THE WIRES ARE TO BE DRESSED IN SUCH A MANNER TO ALLOW THE TERMINALS TO FLOAT FREELY IN THE POCKET.
9. THIS TERMINAL IS DESIGNED FOR SINGLE WIRE CRIMPING.
10. PART CONFORMS TO CLASS 'B' REQUIREMENTS OF COSMETIC SPECIFICATION PS-45499-002.

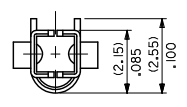
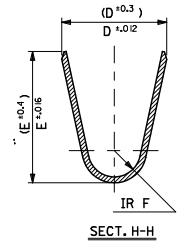
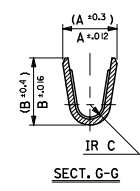
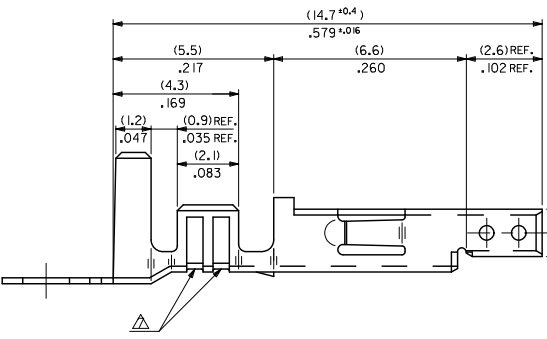

UPDATE VIEW E.C. NO. UEP2011-2362 DRAWN: JAGUILAR 2011/02/09 CHECKED: BELL 2011/02/09 APPROVED: SMITH 2011/02/21	QUALITY SYMBOLS ∇=0 ∇=0 ∇=0	GENERAL TOLERANCES (UNLESS SPECIFIED)		DIMENSION STYLE	SCALE	DESIGN UNITS	THIRD ANGLE PROJECTION	
		mm	INCH	MM/IN	10:1	METRIC	⊙	
		4 PLACES ± --- ± ---	3 PLACES ± --- ± .008	DRAWN BY	DATE	TITLE		
		2 PLACES ± 0.2 ± .008	1 PLACE ± 0.2 ± ---	HIRAMOTO	1991/05/18	MINI FIT JR OVERALL TIN FEMALE CRIMP TERMINAL		
ANGULAR ± 3 °		CHECKED BY	DATE	MATERIAL NO.			SHEET NO.	
		APPROVED BY	DATE	DOCUMENT NO.			1 OF 2	
		FSMITH	2011/02/21	SEE CHART			SD-5556****	
DRAFT WHERE APPLICABLE MUST REMAIN WITHIN DIMENSIONS		THIS DRAWING CONTAINS INFORMATION THAT IS PROPRIETARY TO MOLEX INCORPORATED AND SHOULD NOT BE USED WITHOUT WRITTEN PERMISSION						

12 11 10 9 8 7 6 5 4 3 2 1

13 12 11 10 9 8 7 6 5 4 3 2 1

TIN OVER NICKEL PLATED PHOSPHOR BRONZE	(0.9) .035	(4.5) .177	(3.6) .142	(0.6) .024	(2.7) .106	(2.3) .091	∅ (3.1) .122 MAX.	# 16	39-00-0119	5556 PBS3L	LOOSE
	(0.6) .024	(2.3) .091	(2.3) .091	(0.4) .016	(1.65) .065	(1.8) .071	(0.9-1.8) .035-.071	#22-28	-0118	PBS3	CHAIN
	(0.9) .035	(4.5) .177	(3.6) .142	(0.5) .020	(2.3) .091	(1.9) .075	(1.3-3.1) .051-.122	# 18-24	-0117	PBS2L	LOOSE
TIN PLATED PHOSPHOR BRONZE	(0.9) .035	(4.5) .177	(3.6) .142	(0.6) .024	(2.7) .106	(2.3) .091	∅ (3.1) .122 MAX.	# 16	-0116	PBS2	CHAIN
	(0.6) .024	(2.3) .091	(2.3) .091	(0.4) .016	(1.65) .065	(1.8) .071	(0.9-1.8) .035-.071	#22-28	-0115	PBSL	LOOSE
	(0.9) .035	(4.5) .177	(3.6) .142	(0.5) .020	(2.3) .091	(1.9) .075	(1.3-3.1) .051-.122	# 18-24	-0114	PBS	CHAIN
TIN OVER NICKEL PLATED BRASS	(0.9) .035	(4.5) .177	(3.6) .142	(0.6) .024	(2.7) .106	(2.3) .091	∅ (3.1) .122 MAX.	# 16	-0080	PBT3L	LOOSE
	(0.6) .024	(2.3) .091	(2.3) .091	(0.4) .016	(1.65) .065	(1.8) .071	(0.9-1.8) .035-.071	#22-28	-0079	PBT3	CHAIN
	(0.9) .035	(4.5) .177	(3.6) .142	(0.5) .020	(2.3) .091	(1.9) .075	(1.3-3.1) .051-.122	# 18-24	-0066	PBT2L	LOOSE
TIN OVER COPPER PLATED BRASS	(0.9) .035	(4.5) .177	(3.6) .142	(0.6) .024	(2.7) .106	(2.3) .091	∅ (3.1) .122 MAX.	# 16	-0065	PBT2	CHAIN
	(0.6) .024	(2.3) .091	(2.3) .091	(0.4) .016	(1.65) .065	(1.8) .071	(0.9-1.8) .035-.071	#22-28	-0060	PBTL	LOOSE
	(0.9) .035	(4.5) .177	(3.6) .142	(0.5) .020	(2.3) .091	(1.9) .075	(1.3-3.1) .051-.122	# 18-24	-0059	PBT	CHAIN
MATERIAL	(0.9) .035	(4.5) .177	(3.6) .142	(0.6) .024	(2.7) .106	(2.3) .091	∅ (3.1) .122 MAX.	# 16	-0113	S3L	LOOSE
	(0.6) .024	(2.3) .091	(2.3) .091	(0.4) .016	(1.65) .065	(1.8) .071	(0.9-1.8) .035-.071	#22-28	-0112	S3	CHAIN
	(0.9) .035	(4.5) .177	(3.6) .142	(0.5) .020	(2.3) .091	(1.9) .075	(1.3-3.1) .051-.122	# 18-24	-0111	S2L	LOOSE
	(0.9) .035	(4.5) .177	(3.6) .142	(0.6) .024	(2.7) .106	(2.3) .091	∅ (3.1) .122 MAX.	# 16	-0110	S2	CHAIN
	(0.9) .035	(4.5) .177	(3.6) .142	(0.5) .020	(2.3) .091	(1.9) .075	(1.3-3.1) .051-.122	# 18-24	-0109	SL	LOOSE
	(0.9) .035	(4.5) .177	(3.6) .142	(0.6) .024	(2.7) .106	(2.3) .091	∅ (3.1) .122 MAX.	# 16	-0108	S	CHAIN
	(0.6) .024	(2.3) .091	(2.3) .091	(0.4) .016	(1.65) .065	(1.8) .071	(0.9-1.8) .035-.071	#22-28	-0078	T3L	LOOSE
	(0.9) .035	(4.5) .177	(3.6) .142	(0.5) .020	(2.3) .091	(1.9) .075	(1.3-3.1) .051-.122	# 18-24	-0077	T3	CHAIN
	(0.6) .024	(2.3) .091	(2.3) .091	(0.4) .016	(1.65) .065	(1.8) .071	(0.9-1.8) .035-.071	#22-28	-0047	T2L	LOOSE
	(0.9) .035	(4.5) .177	(3.6) .142	(0.5) .020	(2.3) .091	(1.9) .075	(1.3-3.1) .051-.122	# 18-24	-0046	T2	CHAIN
	(0.9) .035	(4.5) .177	(3.6) .142	(0.6) .024	(2.7) .106	(2.3) .091	∅ (3.1) .122 MAX.	# 16	-0039	TL	LOOSE
	(0.6) .024	(2.3) .091	(2.3) .091	(0.4) .016	(1.65) .065	(1.8) .071	(0.9-1.8) .035-.071	#22-28	39-00-0038	5556 T	CHAIN
	(0.9) .035	(4.5) .177	(3.6) .142	(0.5) .020	(2.3) .091	(1.9) .075	(1.3-3.1) .051-.122	# 18-24			

SEE SHEET 1 EC NO. UEP2011-2362 DRWG: JAGUTLAR 2011/02/09 CHKD: BELL 2011/02/09 APPR: FSMITH 2011/02/21	QUALITY SYMBOLS ∇=0 ∇=0 ∇=0	GENERAL TOLERANCES (UNLESS SPECIFIED)		DIMENSION STYLE MM/IN		SCALE	DESIGN UNITS METRIC	THIRD ANGLE PROJECTION	
		4 PLACES ± --- ± --- 3 PLACES ± --- ± .008 2 PLACES ± 0.2 ± .008 1 PLACE ± 0.2 ± --- ANGULAR ± 3 °	mm INCH	DRAWN BY HIRAMOTO	DATE 1991/05/18	TITLE MINI FIT JR OVERALL TIN FEMALE CRIMP TERMINAL		MOLEX INCORPORATED	
DRAFT WHERE APPLICABLE MUST REMAIN WITHIN DIMENSIONS	SIZE C	MATERIAL NO. SEE CHART		DATE 2011/02/21		DOCUMENT NO. SD-5556****		SHEET NO. 2 OF 2	
THIS DRAWING CONTAINS INFORMATION THAT IS PROPRIETARY TO MOLEX INCORPORATED AND SHOULD NOT BE USED WITHOUT WRITTEN PERMISSION									

Id_frame_C_P_AM_T
Rev. F 2009/06/18

12 11 10 9 8 7 6 5 4 3 2 1